

PRO 2022





#IZAR50yearsinternational



Carlos Pujana

CEO

IZAR Cutting Tools SAL

izar@izartool.com

Amorebieta 02.01.2022

Estimados clientes, colaboradores y amigos,

Este Catálogo Profesional supone la culminación de un trayecto que comenzó en 1998, con el primer catálogo de IZAR que tuve el honor de prologar.

Continuamos ampliando sin descanso la gama de soluciones innovadoras para nuestros clientes en brocas para metal, madera y pared, así como todo tipo de herramientas relacionadas con las mismas.

Ejemplo de ello, la nueva broca de Zirkonio en envase individual EV pack 1065, los rompe-machos 9016, la nueva gama de aceites de corte 3415 y los nuevos estuches de brocas 1459, que incluyen las medidas previas al roscado.

Reforzamos nuestro compromiso con la sostenibilidad y el medioambiente, consumiendo energía con garantía de origen 100% renovable y unimos a ello, incluso, nuestra gama de envasados OLATU, concebida bajo parámetros de eco-diseño que, como ya es bien conocido, supone una reducción del impacto ambiental en todo el ciclo de vida del producto de un 64%. Esta gama se ampliará, presentando importantes novedades y mejoras en un futuro muy cercano.

Hemos querido modernizar, no solo el diseño de las herramientas y los envasados, sino incluso el propio catálogo, que como podrán observar, con 400 páginas y 8.700 artículos, es el más amplio editado hasta la fecha. Ahora es más sencillo y fácil identificar que nunca antes la herramienta que necesitamos, y el modo más responsable y eficiente de utilizarla.

Finalmente, a pesar de nuestro compromiso con la estabilidad de precios, la evolución de las materias primas, de la energía y de los fletes, se han combinado de tal forma, que han generado la mayor espiral inflacionista imaginable. Esto nos obliga a actualizar nuestros precios, que se incrementan en el entorno de un 6%, como media, aproximadamente. No es un incremento lineal, sino que hemos querido ser cuidadosos y hemos evaluado el impacto de la subida de forma individual, artículo por artículo.

Todo ello viene además combinado con un reajuste de la política de descuentos, que tiene un impacto cero en nuestros distribuidores, pero que acerca los precios publicados a los precios reales de venta al usuario final, lo que es esencial en esta nueva era de las nuevas tecnologías y de la transparencia en la que vivimos.

Estamos muy agradecidos de contar con su confianza pues, sin ustedes, nada de lo que hacemos tendría sentido.

Dear customers, business partners and friends,

This Professional Catalogue is the culmination of a journey that began in 1998, with the first IZAR catalogue, which I had the honour of prefacing.

We continue to relentlessly expand the range of innovative solutions for our customers, in drill bits for metal, wood and masonry, as well as all types of related tools.

For example, the new 1065 Zirkonio drill bit in individual EV packaging, the 9016 tap breakers, the new 3415 range of cutting oils and the new 1459 drill bit sets, which include measures prior to threading.

We reinforce our commitment to sustainability and the environment, consuming energy with a guarantee of 100% renewable origin. We add to this our OLATU range of packaging, conceived under eco-design parameters which, as is already well known, means a 64% reduction in the environmental impact throughout the product's life cycle. This range will be expanded, with important new features and improvements in the very near future.

We wanted to modernise not only the design of the tools and packaging, but also the catalogue itself. As you will see, with 400 pages and 8,700 articles, it is the most extensive catalogue published to date. It is now simpler and easier than ever before to identify the tool we need, and the most responsible and efficient way to use it.

Finally, despite our commitment to price stability, the evolution of raw materials, energy and freight rates have combined in such a way as to generate the largest inflationary spiral imaginable. This forces us to update our prices, which increase by approximately 6% on average. It is not a linear increase; instead, we wanted to be careful and we have assessed the impact of the increase on an item-by-item basis.

This is combined with a readjustment of the discount policy, which has zero impact on our distributors, but brings the published prices closer to the real sales prices to the end user. This is essential in this new era of new technologies and transparency in which we live.

We are very grateful for your trust, as, without you, none of what we do would make sense.

Chers clients, collaborateurs et amis,

Ce catalogue professionnel est l'aboutissement d'un parcours qui a commencé en 1998, avec le premier catalogue IZAR, dont j'ai eu l'honneur de préfacer.

Nous continuons à élargir sans relâche la gamme de solutions innovantes pour nos clients en matière de forets pour le métal, le bois et la maçonnerie, ainsi que tous les outils connexes.

Citons par exemple les nouveaux forets Zirkonio en pack individuel EV 1065, les forets à mortaiser 9016, la nouvelle gamme d'huiles de coupe 3415 et les nouveaux coffrets de forets 1459, qui incluent les mesures préalables au taraudage.

Nous renforçons notre engagement envers la durabilité et l'environnement, en consommant de l'énergie avec une garantie d'origine 100 % renouvelable et nous ajoutons à cela notre gamme d'emballages OLATU, conçue selon des paramètres d'éco-conception qui, comme on le sait déjà, signifie une réduction de 64 % de l'impact environnemental tout au long du cycle de vie du produit. Cette gamme sera étendue, avec d'importantes nouveautés et améliorations dans un avenir très proche.

Nous avons voulu moderniser non seulement le design des outils et des emballages, mais aussi le catalogue lui-même, qui, comme vous pouvez le constater, avec 400 pages et 8 700 articles, est le catalogue le plus complet publié à ce jour. Il est aujourd'hui plus simple et plus facile que jamais d'identifier l'outil dont nous avons besoin, ainsi que la manière la plus responsable et la plus efficace de l'utiliser.

Enfin, malgré notre engagement en faveur de la stabilité des prix, l'évolution des matières premières, de l'énergie et des frets se sont combinés de manière à générer la plus grande spirale inflationniste imaginable. Cela nous oblige à actualiser nos prix, qui augmentent d'environ 6 % en moyenne. Il ne s'agit pas d'une augmentation linéaire, mais nous avons voulu être prudents et nous avons évalué l'impact de l'augmentation article par article. Ceci est combiné à un réajustement de la politique de réductions, qui a un impact nul sur nos distributeurs, mais rapproche les prix publiés des prix de vente réels à l'utilisateur final, ce qui est essentiel dans cette nouvelle ère de nouvelles technologies et de transparence dans laquelle nous vivons.

Nous vous remercions vivement de votre confiance, car sans vous, rien de ce que nous faisons n'aurait de sens.

UNA EMPRESA CON VALORES

A Company With Values

Une entreprise avec des valeurs

Valores IZAR

- La honestidad
- El enfoque al cliente
- La adaptación al cambio
- El compromiso con la calidad y con el trabajo bien hecho
- El trabajo en equipo
- El interés por la tecnología y por la innovación

IZAR Values

- Honesty
- Customer focus
- Adaptation to change
- Commitment to quality and to the job well done
- Team-work
- Interest for technology and innovation

Valeurs IZAR

- L'honnêteté
- L'orientation client
- L'adaptation au changement
- L'engagement pour la qualité et pour le travail bien fait
- Le travail en équipe
- L'intérêt pour la technologie et l'innovation

UNA EMPRESA SOCIALMENTE RESPONSABLE

A socially responsible company

Une entreprise socialement responsable



Premio Zirgari a la igualdad de género en el mundo de la industria

Zirgari award for gender equality in the world of industry

Prix Zirgari de l'égalité femmes-hommes dans le monde de l'industrie



COMPROMETIDOS CON LA FABRICACIÓN Y EL EMPLEO

Committed to manufacturing and jobs

Engagés dans la fabrication et l'emploi

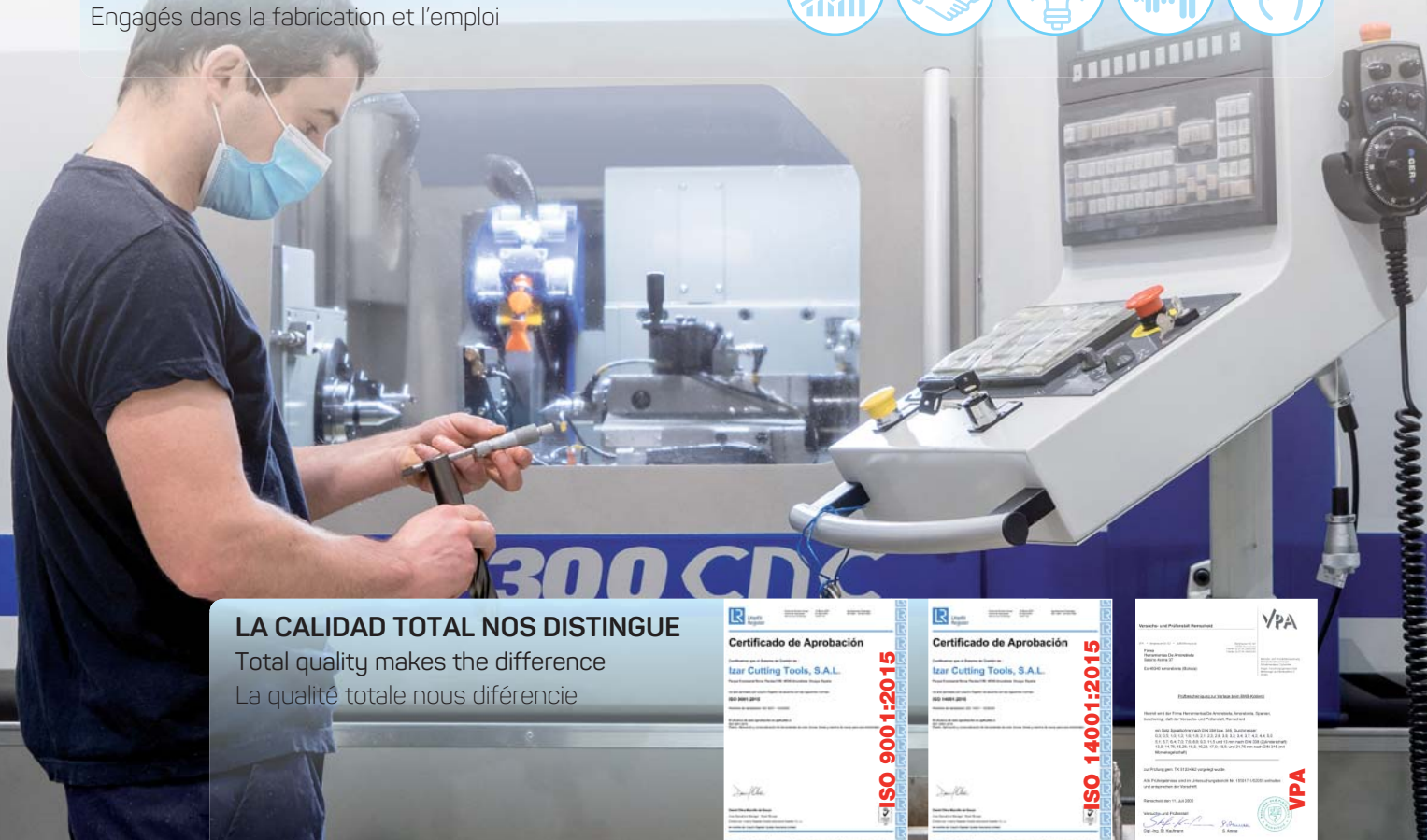

LA CALIDAD TOTAL NOS DISTINGUE

Total quality makes the difference

La qualité totale nous différencie



EXPORTADORES A NIVEL MUNDIAL

A Major Figure in the global market

Présent sur tous les marchés mondiaux

Export Sales

Tel. (+34) 94 630 02 46

Fax. (+34) 94 630 02 37

export@izartool.com

Ventes France

Tel. (+34) 94 630 02 45

Fax. (+34) 94 630 02 37

france@izartool.com



1 **Idoia Luengas**

iluengas@izartool.com

2 **Aitxiber Soutiño**

asoutino@izartool.com

3 **Joseba Del Pozo**

Chef Produit Technique
jdelpozo@izartool.com

4 **Itziar Urrutxua**

iurrutxua@izartool.com

5 **Mikel Goyarrola**

Export Manager
mgoyarrola@izartool.com

6 **Xabier Asensio**

Export Area Manager
xasensio@izartool.com

7 **Maite Olariaga**

molariaga@izartool.com

8 **Juan Garaizar**

General Sales Manager
jgaraizar@izartool.com

9 **Ostaizka Badiola**

obadiola@izartool.com



Presencia Internacional
International Presence
Présence Internationale

Top Service
Opening Hours:
8.00 - 19.00

**Service 24h
en France**

Pour commandes de articles
en stock reçues avant 14.30h

LÍDERES EN MERCADO NACIONAL

Domestic market leaders

Leader sur le marché national



Ventas Mercado Nacional

Tel. 94 630 02 41

Fax. 94 630 02 36

comercial@izartool.com

1 Leticia González
Administrativa Comercial

3 Mari Feli Arrizabalaga
Administrativa Comercial

5 Juan Garaizar
Director Comercial
jgaraizar@izartool.com

7 Mónica González
Directora de Ventas Nacional
mgonzalez@izartool.com

9 Yolanda Barrena
Administrativa Comercial

2 Oiane Gortazar
Product Manager
Professional
ogortazar@izartool.com

4 Olaia Etxebarria
Administrativa Comercial

6 Iskander Ibaruri
Asistencia Técnica
iibaruri@izartool.com

8 Leire Layana
Administrativa Comercial

10 Iker Beobide
Product Manager Industrial
ibeobide@izartool.com

11 Isabel Hernández
Administrativa Comercial



Servicio 24h
Horario de
Atención al Cliente:
8.00 - 19.00



ÍNDICE VISUAL

Visual Index
Index visuel

METAL

Ref.	Material	Icon	Multi	Pack	Pag.
1021	HSSE 5% Co		INOX	MULTI-PACK	16
1004	HSSE 5% Co		INOX	BLISTER	19
1016	HSSE 5% Co	DIN 338 N	Hard Mats. Duros	MULTI-PACK	22
1006	HSSE 5% Co	DIN 338 N	Hard Mats. Duros	BLISTER	26
1020	HSSE 5% Co		INOX Stainless	MULTI-PACK	31
1005	HSSE 5% Co		INOX Stainless	BLISTER	34
1027	HSSE 5% Co	L30 mm		MULTI-PACK	37
9015	Metal Duro				38
9289	MD/HM Carbure			New!	38
9100	Metal Duro				39
1015	HSS + ZIRKONIO	DIN 338 N		MULTI-PACK	40
1065	HSS + ZIRKONIO	DIN 338 N		BLISTER New!	43
1010	HSS + TIN	DIN 338 N	Uso General	MULTI-PACK	45
1001	HSS + TIN	DIN 338 N	Uso General	BLISTER	50
1013	HSS + TIALSIN		Max. 5 mm	MULTI-PACK	56
1002	HSS		Max. 5 mm	BLISTER	60
1007	HSS	L30 mm		BLISTER	65
1025	HSS	DIN 338 N		MULTI-PACK	67

Ref.	Material	Icon	Multi	Pack	Pag.
1660	HSS		Max. 3 mm	MULTI-PACK	68
1050	HSS	DIN 1897 N	Extra-Corta	MULTI-PACK	69
1030	HSS	DIN 340 N	Larga Long	MULTI-PACK	70
1003	HSS	DIN 340 N	Larga Long	MULTI-PACK	72
1040	HSS	DIN 1869 N	Extra Larga		74
1090	HSS	Laminada Rolled Laminé		MULTI-PACK	75
1009	HSS	Laminada Rolled Laminé		BLISTER	75
1110	HSS	DIN 345 N	Cónica Taper		76
1802					79
1806			Reversible		80
1804			Dcha. Right		80
1803			Dcha. Right		81
1101	HSS	DIN 2185			84
1102	HSS	DIN 2187			84
1103	HSS				85
MÁQUINA AFILADORA BROCAS Drill Bit Sharpening Machine Machine affûteuse forets					
9994					86
1602	HSS		Max. 4 mm		87

ÍNDICE VISUAL

Visual Index
Index visuel































METAL

		Pag.			Pag.
Ref. 1612	HSS	Espiral			89
Ref. 1607	HSSE 5% Co				90
Ref. 1617	HSSE 5% Co	Espiral			91
Ref. 1603	HSS				92
Ref. 1609	HSSE 5% Co				93
Ref. 1611	HSS				94
Ref. 1606	HSS				95
Ref. 1610	HSS	DIN 3126			96
Ref. 4078	TCT	Serie Corta Short Length Série courte			97
Ref. 4077	TCT	Serie Larga Long Length Série longue			98
Ref. 4070	HSS	Serie Corta Short Length Série courte			99
Ref. 4071	TCT	Serie Larga Long Length Série longue			100
Ref. 4072	HSS	S. Extra-Larga Extra-Long S. S. extra-longue			101
Ref. 4079	HSS	Serie Corta Short Length Série courte			102
Ref. 4076	HSS	DOBLE WELDON			103
Ref. 4074	DOBLE WELDON				104
Ref. 4067	TCT	Serie Larga Long Length Série longue			107
Ref. 4060	HSS	Serie Corta Short Length Série courte			108
Ref. 4061	HSS	Serie Larga Long Length Série longue			109
Ref. 4062	HSS	S. Extra-Larga Extra-Long S. S. extra-longue			110
Ref. 1667	HSS				111
Ref. 1663	INOX Stainless	PVC Aluminio			113
Ref. 1665	INOX Stainless	PVC Aluminio			114
Ref. 1636	HSS	New!			115
Ref. 2010	HSS	DIN 206 B ISO 236			116
Ref. 2015	HSS	Reforzado Reinforced Renforcée			117
Ref. 2016	HSS	Con guía Guided Avec guide			117
Ref. 2575	HSSE 5% Co	DIN 335 C			118
Ref. 2530	HSS	DIN 373 Allen			119
Ref. 2572	HSSE 5% Co				120
Ref. 3030	HSS	DIN 352 Mano Hand Main			121
Ref. 3003	HSS	DIN 352 Mano Hand Main			122
Ref. 3036	HSSE 5% Co	DIN 352 / 2181 INOX Stainless			124
Ref. 3037	HSSE 5% Co	DIN 352 / 2181 INOX Stainless			125

ÍNDICE VISUAL

Visual Index
Index visuel

METAL

				Pag.					Pag.		
Ref. 3020	HSS	DIN 2181	Nº1 Nº3		126	Ref. 3217	HSSE 5% Co	ISO 529		142	
				PACK							
Ref. 3010	HSS	DIN 352 / 2181	Nº3		128	Ref. 3109	HSS	ISO 529		143	
				PACK					PACK		
Ref. 3001	HSS	DIN 352	Nº3		130	Ref. 3207	HSS	ISO 529		144	
				BLISTER					PACK		
Ref. 3023	HSS	DIN 352			131	Ref. 3157	HSS	ISO 529		145	
				PACK					PACK		
Ref. 3040	HSS	ISO 529	Nº3		132	Ref. 3247	HSS	ISO 529		146	
				PACK					PACK		
Ref. 3032	HSS	DIN 352	Whitworth		133	Ref. 3500	M / MF	HSS	DIN 223		147
				PACK					PACK		
Ref. 3012	HSS	DIN 352	Whitworth		134	Ref. 3005	HSS	DIN 223	Mano Hand Main		149
				PACK							
Ref. 3026	HSS	DIN 5157	Gas (BSP)		135	Ref. 3536	HSSE 5% Co	DIN 22568	INOX Stainless		150
				PACK					PACK		
Ref. 3016	HSS	DIN 5157	Gas (BSP)		135	Ref. 3510	HSS	ISO 529			151
				PACK					PACK		
Ref. 3100	HSSE 5% Co	DIN 371	Máq.		136	Ref. 3502	DIN 223	Whitworth			151
				PACK					PACK		
Ref. 3200	HSSE 5% Co	DIN 376/ 374	Máq.		137	Ref. 3546	HSSE 5% Co	DIN 24231	INOX Stainless		152
				PACK					PACK		
Ref. 3150	HSSE 5% Co	DIN 371	Máq.		139	Ref. 3506	Gas (BSP)	HSS	DIN 24231		152
				PACK					PACK		
Ref. 3250	HSSE 5% Co	DIN 376/ 374	Máq.		140	Ref. 3191	DIN 1814				153
				PACK							
Ref. 3119	HSSE 5% Co	ISO 529			141	Ref. 3912	"T" + Criqué				153
				PACK							
Ref. 3409					155	Ref. 9016	MD/HM Carbure	IZAR Std.		154	
									New!		
Ref. 3181	DIN 225				156						

ÍNDICE VISUAL

Visual Index
Index visuel

























METAL

				Pag.					Pag.
<div style="border: 2px solid red; padding: 5px;"> <div style="display: flex; align-items: center;"> <div style="border: 1px solid red; padding: 2px; margin-right: 5px;">New!</div> <div style="border: 1px solid red; padding: 2px; margin-right: 5px;">Ref. 3415</div> <div style="margin-left: 10px;"> ACEITES DE CORTE Y REFRIGERANTES Cutting Oils & Water Soluble Fluids Huiles de coupe et lubrifiants </div> </div> <div style="display: flex; justify-content: space-around; margin-top: 10px;"> <div style="text-align: center;"> Universal </div> <div style="text-align: center;"> Heavy Duty </div> <div style="text-align: center;"> Non Ferrous </div> </div> <div style="display: flex; justify-content: space-around; margin-top: 10px;"> <div style="text-align: center;"> Standard </div> <div style="text-align: center;"> Top Line </div> </div> </div>				159					
Ref. 3300	HSS	M / MF		165					
Ref. 3305	HSS	M / MF		166					
Ref. 3303				167					
Ref. 3307				167					
Ref. 9260	K20 + ALTiN	Norma ZYA-S		170					
Ref. 9250	K20 + ALTiN	Norma ZYA		171					
Ref. 9251	K20 + ALTiN	Norma WRC	Radial Radial Hemisférica	171					
Ref. 9252	MD/HM K20	Norma WKN	Cono Invertido Inverted Cone Coupe en bout	172					
Ref. 9254	K20 + ALTiN	Norma SPG	Ojiva Tree Ogive	172					
Ref. 9255	MD/HM K20	Norma SKM	Cónica Cone Conique	173					
Ref. 9256	MD/HM K20	Norma KSK	Cónica 90° 90° Cone Conique 90°	173					
Ref. 9257	MD/HM K20	Norma TRE	Gota Oval Ovale	174					
Ref. 9258	K20 + ALTiN	Norma KUD	Esférica Ball Sphérique	174					
Ref. 9266	MD/HM K20	Norma B	Llama Flame Flamme	175					
Ref. 9267	MD/HM K20	Norma KEL	Redondeada Ball Nosed Conique rayon	175					
Ref. 9268	K20 + ALTiN	Norma RBF	Ojiva redondeada Ball Nosed Tree Ogive rayon	176					
Ref. 9240	MD/HM Carbure	Norma ZYA-S		176					
Ref. 9230	MD/HM Carbure	Norma ZYA		177					
Ref. 9231	MD/HM Carbure	Norma WRC	Radial Radial Hemisférica	177					
Ref. 9237	MD/HM Carbure	Norma TRE	Gota Oval Ovale	178					
Ref. 9238	MD/HM Carbure	Norma KUD	Esférica Ball Sphérique	178					
Ref. 9247	MD/HM Carbure	Norma KEL	Cónica Redon. Ball Nosed Cone Conique rayon	179					
Ref. 9248	MD/HM Carbure	Norma RBF	Ojiva Redon. Ball Nosed Tree Ogive rayon	179					
Ref. 9674	MD/HM Carbure	IZAR Std.		182					
Ref. 9459	MD/HM Carbure		Grabado Engraving Gravure	183					
Ref. 9419	K10F + ALTiN	W	Alumini- nio	184					
Ref. 9411	K10F + ALTiN	W	Alumini- nio	184					
Ref. 4412	HSS	W	Alumini- nio	185					
Ref. 4414	HSS	W	Alumini- nio	185					
Ref. 4223	HSSE 8% Co			187					
Ref. 4228	HSSE 8% Co	4% Cr		189					
Ref. 4229	HSSE 8% Co	4% Cr		191					
Ref. 1994	TPI 24			192					
Ref. 1999	Bimetal	TPI 18-24 32	INOX Stainless	192					
Ref. 1997	HSS	TPI 18-24 32	No Flexible	192					











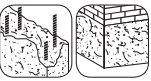





ÍNDICE VISUAL

Visual Index
Index visuel

METAL

				Pag.					Pag.	
Ref. 1996	CrV	TPI 24		192	Ref. 8990	HSSE 10% Co	DIN 4964B		200	
Ref. 8901	DIN 4971	ISO 1	Cilindrado 70° 70° Straight Cylindrage 70°		194	Ref. 8991	HSSE 10% Co	DIN 4964A		200
Ref. 8900	DIN 4972	ISO 2	Escuadrado 45° 45° Bent Décolletage 45°		194	Ref. 8992	HSSE 10% Co	DIN 4964E		201
Ref. 8904	DIN 4976	ISO 4	Ranurado Ext. Wide Face Square Rainurage ext.		195	Ref. 8350				204
Ref. 8910	DIN 4980	ISO 6	Escuadrado 90° 90° Offset Side Décolletage 90°		195	Ref. 8325	3-25 mm	1/8-1"		206
Ref. 8920	DIN 4981	ISO 7	Tronzado Parting Tronçonnage		196	Ref. 8330	3-30 mm	1/8-1" 1/8		206
Ref. 8925	DIN 4973	ISO 8	Mandrinado Boring Straight Alésage		196	Ref. 8335	3-35 mm	1/8-1" 3/8		206
Ref. 8930	DIN 4974	ISO 9	Cilindrado int. Internal Sharped Cylindrage int.		197	Ref. 8341				206
Ref. 8940	DIN 4975	ISO 10	Cilindrado Recto Sharped Straight Cylindrage Droit		197	Ref. 8326	26 mm	1"	Inox + Teflon 	207
Ref. 8950	DIN 263	ISO 11	Ranurado Int. Int. Undercutting Rainurage int.		198	Ref. 8342	42 mm	1" 5/8	Inox + Teflon 	207
Ref. 8960	DIN 282	ISO 12	Roscado Ext. Ext. Threading Taraudage ext.		198	Ref. 8321				207
Ref. 8970	DIN 283	ISO 13	Roscado Int. Int. Threading Taraudage int.		199	Ref. 8345				208

CONSTRUCCIÓN Construction

























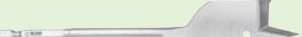

















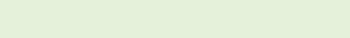









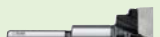







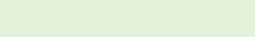









				Pag.					Pag.
Ref. 1891	SDS plus			210	Ref. 1894	SDS max			222
Ref. 1890	SDS plus			214	Ref. 1697	SDS max			223
Ref. 1695	SDS plus			219	Ref. 1875	SDS max			225
Ref. 1892	SDS max			220	Ref. 1870	SDS plus			226

CONSTRUCCIÓN Construction

Ref.	Icons	Image	Pag.
1872	SDS max, Concrete, Brick		227
1871	Concrete, Hammer, Brick		229
1882	Concrete, Porcelain, Drill		230
1879	Concrete, Porcelain, Drill		231
1883	Concrete, Porcelain, Drill		232
1877	Concrete, Granite, Drill		233
1886	MD/HM TCT, Concrete, Brick		234
1846	MD/HM TCT, Concrete, Brick		235
1880	MD/HM TCT, Concrete		238
1881	Ceramic, Concrete, Brick		242
1836	MD/HM, Concrete, Ceramic		244
1601	MD/HM TCT, Concrete		245
1645	HSSE 8% Co, Concrete, Brick		247
1647	Ceramic, Concrete, Brick		250
1661	Ceramic, Concrete, Brick		252
1662	Ceramic, Concrete, Brick		253
1860	Concrete, Brick, Drill		256

Ref.	Icons	Image	Pag.
1851	Concrete, Brick, Drill, Wheel		258
1852	Concrete, Brick, Drill, Wheel		258
1858	Concrete, Brick, Drill, Wheel		259
1854	Concrete, Brick, Drill, Wheel		259
1855	Concrete, Brick, Drill, Abrasivos, Wheel		260
1853	Concrete, Brick, Drill, Wheel		260
1861	Concrete, Brick, Drill, Wheel		261
1857	Concrete, Brick, Drill, Wheel		261
1864	Concrete, Brick, Drill, Wheel		262
1862	Concrete, Brick, Drill, Wheel		262
1863	Concrete, Brick, Drill, Wheel		263
1849	Concrete, Brick, Drill, Wheel		263
8309	9 mm		264
8318	18 mm, 'New!'		264
8319	19 mm, 'New!'		265

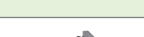
MADERA Wood Bois

				Pag.					Pag.
Ref. 1641	HSS			268	Ref. 1670	MD/HM Carbure			287
Ref. 1640	CrV			270	Ref. 1671	MD/HM Carbure			287
Ref. 1651	Heavy Duty	 		274	Ref. 1672	MD/HM Carbure			288
Ref. 1650		 		276	Ref. 1673	MD/HM Carbure			288
Ref. 1655	CrV			278	Ref. 1681	MD/HM Carbure			288
Ref. 1644	SDS plus	 		280	Ref. 1682	MD/HM Carbure			289
Ref. 1643		 		281	Ref. 1686	MD/HM Carbure			289
Ref. 1621	CrV			282	Ref. 1615	Diente MD			291
Ref. 1639	HSS			283	Ref. 1620	HSS			292
Ref. 1637	C45	New! 		284	Ref. 1625				292
Ref. 1685	MD/HM Carbure			285	Ref. 1689	MD/HM Carbure	EVA 		293
Ref. 1669	MD/HM Carbure			285	Ref. 9001	MD/HM Carbure	 Max. 1 mm		293
Ref. 1679	MD/HM Carbure			285	Ref. 7009	MD/HM Carbure	 Ceramic		294
Ref. 1678	MD/HM Carbure			286	Ref. 7002	HSS	 Pladur Escayola		294
Ref. 1674	MD/HM Carbure			286	Ref. 7003	HSS	 Auto center		295
Ref. 1676	MD/HM Carbure			286	Ref. 7001	HSS			295
Ref. 1677	MD/HM Carbure			287	Ref. 1690	MD/HM Carbure			296

ÍNDICE VISUAL

Visual Index
Index visuel

SIERRAS Saw Blades Lames scies

Ref.	Iconos	Imagen	Pag.	Ref.	Iconos	Imagen	Pag.
2940	STARLOCK, Madera		301	1960	Sable, Especial		330
2910	STARLOCK, Metal		305	1940	Calar, Inserción "T", Madera		338
2930	STARLOCK, Especial		310	1910	Calar, Inserción "T", Metal		347
2950	QUICK-FIT, Especial		318	1930	Calar, Inserción "T", Especial		352
1950	Sable, Madera		322	1945	Calar, Inserción "U", Madera		353
1920	Sable, Metal		325	1915	Calar, Inserción "U", Metal		355

PUNTAS ATORNILLAR Screwdriver Bits Embouts vissage

Ref.	Iconos	Imagen	Pag.	Ref.	Iconos	Imagen	Pag.
1520	Std.		358	1522	Zirkonio		364
1521	Torsión		362				

DOBLE BLISTER Double Blister Double Blister

Ref.	Iconos	Imagen	Pag.	Ref.	Iconos	Imagen	Pag.
M021	Cobalto 5% HSSE, Madera		370	M886	Punta MD/HM Point, Madera, Percusión		376
M020	Cobalto 5% HSSE, Metal		371	M880	Punta MD/HM Point, Metal, Percusión		377
M013	HSS, Metal		372	M881	Madera, Metal, Metal		378
M007	HSS, L30 mm, Metal		373	M836	Punta MD/HM Point, Sin percusión, Metal		378
M890	SDS plus, Metal, Percusión		374	M640	CrV, Metal		379
M882	Punta MD/HM Point, Sin percusión, Metal		375	M650	Metal, Metal		380

ÍNDICE GENERAL

General Index
Index général



METAL

Metal
Métal

15

BROCAS

Twist Drills
Forets

16

PORTA-BROCAS Y ACCESORIOS

Drill Chucks & Accessories
Mandrins et accessoires

79



CONSTRUCCIÓN

Construction
Construction

209



MADERA

Wood
Bois

267

BROCAS

Drill Bits
Forets

268

FRESAS

Router Cutters
Fraises

285

SIERRAS

Saw Blades
Lames scies

297

OSCILANTES MULTI-FUNCIÓN

Oscillating Multi-Tools
Outils Multifonction

298

SIERRAS SABLE

Sabre Saw Blades
Lames scie sabre

320

SIERRAS CALAR

Jig Saw Blades
Lames scies sauteuses

336

PUNTAS ATORNILLAR

Screwdriver Bits
Embouts vissage

357

BROCAS ESPECIALES

Special Twist Drills
Forets Spéciales

87

FRESAS HUECAS

Hole-Cutters
Fraises à carotter

97

CORONAS

Hole Saws
Trépan

111

ESCARIADORES

Reamers
Alésoirs

116

AVELLANADORES

Countersinks / Counterbores
Outils

118

MACHOS Y COJINETES

Taps & Dies
Tarauds et filières

121

HERRAMIENTAS SDS PLUS

SDS plus Tools
Outils SDS plus

210

HERRAMIENTAS SDS MAX

SDS max Tools
Outils SDS max

220

ADAPTADOR iCONNECT

iConnect Adaptor
Adaptateur iConnect

224

CINCELES

Chisels
Burins

226

ACEITE / LUBRICANTE CORTE

Cutting Oil / Coolant
Huile / Lubrifiant de coupe

159

REPARADORES ROSCAS

Thread Repairs
Filets rapportés

164

FRESAS ROTATIVAS, FRESAS FRONTALES

Rotary Burrs, End Mills
Fraises limes rotatives, Fraises

170

HOJAS DE SIERRAS DE CINTA

Band Saw Blades
Lames de scie à ruban

186

HERRAMIENTAS TORNEADO

Brazed Turning Tools
Outils de tour

193

BROCAS MANGO CILÍNDRICO

Straight Shank Drill Bits
Forets queue cylindrique

230

CORONAS

Hole Saws
Trépan

247

DISCOS DIAMANTE

Diamond Cutting Blades
Disques diamant

257



DOBLE BLISTER

Double Blister
Double Blister

369

METAL

Metal
Métal

370

CONSTRUCCIÓN

Construction
Construction

374

MADERA

Wood
Bois

379

PRESENTACIONES

Presentations
Presentations

381

PRESENTACIÓN IZAR EN LÍNEA

IZAR Line Presentation
Presentation IZAR ligne

382

PRESENTACIÓN IZAR EN CASCADA

IZAR Cascade Presentation
Presentation IZAR cascade

390

EXPOSITORES APILABLES

Stacking Exhibitors
Présentoirs apilables

394

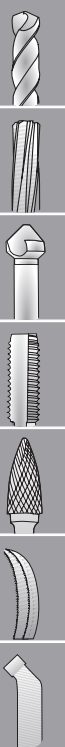

METAL

Metal
Métal

BROCAS

Drill Bits
Forets

16

PORTABROCAS Y ACCESORIOS

Drill Chucks & Accessories
Mandrins et accessoires

79

BROCAS ESPECIALES

Special Drill Bits
Forets spéciales

87

FRESAS HUECAS

Hole-Cutters
Fraises à carotter

97

CORONAS

Hole Saws
Trépan

111

ESCARIADORES

Reamers
Alésoirs

116

AVELLANADORES

Countersinks / Counterbores
Outils

118

MACHOS Y COJINETES

Taps & Dies
Tarauds et filières

121

ACEITE / LUBRICANTE CORTE

Cutting Oil / Coolant
Huile / Lubrifiant de coupe

159

REPARADORES ROSCAS

Thread Repairs
Filets rapportes

164

FRESAS ROTATIVAS, FRESAS FRONTALES

Rotary Burrs, End Mills
Fraises limes rotatives, fraises

170

HOJAS DE SIERRAS DE CINTA

Band Saw Blades
Lames de scie à ruban

186

HERRAMIENTAS TORNEADO

Brazed Turning Tools
Outils de tour

193



BROCAS

Drill Bits
Forets

Ref. **1021**

BROCA UNIVERSAL COBALTO MULTI INOX

Multi-STAINLESS Cobalt Universal Drill Bit
Foret universel cobalt Multi INOX



BOROA



Aceros <850 N/mm ² Steel / Aciers	INOX Stainless Steel Acier INOX	Cobre Copper Cuivre	Aluminio Aluminium
---	--	----------------------------------	------------------------------

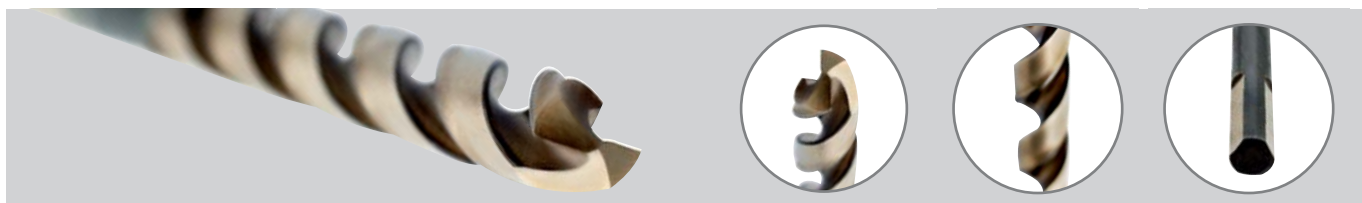

Ángulo de Punta 135°:

- Especial taladro mano.
- Aguzado de gran precisión.
- Menor fuerza de corte.
- Buen centrado superficies curvas.

Hélice 40°:

- Excelente evacuación de viruta.
- Taladrado más rápido y estable.
- Agujeros precisos hasta el final.

Mango de 3 Planos:

- Óptimo agarre y sujeción.
- Menor esfuerzo.
- Evita que se resbale la broca.
- Inmejorable transmisión de la energía.

135° Point Angle:

- Special portable drilling machine.
- High precision Split Point.
- Lower cutting-forces.
- Good centering on concave surfaces.

40° Helix:

- Excellent chip removal.
- Faster & stable drilling.
- Accurate holes right to the end.

3-Flat Shank:

- Optimum fixing.
- Low effort.
- No spinning in the drill-chuck.
- Ideal energy-transmission.

Angle de pointe 135°:

- Perceuses à main
- Affûtage précision
- Force de coupe inférieure
- Autocentrage surfaces courbes

Helix 40°:

- Excellente évacuation copeaux
- Perçage plus rapide et stable
- Trous précis jusqu'au bout

Queue 3 plans:

- Fixation optimale
- Effort inférieur
- Pas de glissement du foret
- Transmission d'énergie parfait

D mm	L mm	I mm		Nº Art.	€
1,00	34	12	10	25641	2,43
1,25	38	16	10	25642	2,90
1,50	40	18	10	25644	2,32
1,75	46	22	10	69953	2,90
2,00	49	24	10	25645	2,32
2,25	53	27	10	25646	2,56
2,50	57	30	10	25647	2,11
2,75	61	33	10	25648	2,56
3,00	61	33	10	25650	2,06
3,20	65	36	10	25710	2,54
3,25	65	36	10	25728	2,54
3,30	65	36	10	25730	2,54
3,50	70	39	10	25733	2,49
3,75	70	39	10	25738	3,01
4,00	75	43	10	25744	2,71
4,20	75	43	10	25751	3,01
4,25	75	43	10	25756	3,01
4,50	80	47	10	25762	3,01
4,75	80	47	10	25764	3,35

D mm	L mm	I mm		Nº Art.	€
5,00	86	52	10	25769	3,23
5,20	86	52	10	25774	4,00
5,25	86	52	10	25777	3,77
5,50	93	57	10	25780	4,08
5,75	93	57	10	25786	4,56
6,00	93	57	10	25788	4,35
6,25	101	63	10	25790	4,99
6,50	101	63	10	25793	5,08
6,75	109	69	10	25795	5,96
6,80	109	69	10	25798	5,94
7,00	109	69	10	25801	5,53
7,25	109	69	10	25803	7,59
7,50	109	69	10	25805	5,89
7,75	117	75	10	69952	9,11
8,00	117	75	10	25807	6,89
8,25	117	75	5	25809	8,76
8,50	117	75	5	25811	7,20
8,75	125	81	5	69950	11,05
9,00	125	81	5	25813	9,16

D mm	L mm	I mm		Nº Art.	€
9,25	125	81	5	69949	12,22
9,50	125	81	5	25815	9,48
9,75	133	87	5	69947	14,41
10,00	133	87	5	25817	10,47
10,20	133	87	1	32666	14,11
10,25	133	87	1	25819	18,40
10,50	133	87	1	25821	14,11
10,75	142	94	1	69946	20,28
11,00	142	94	1	25823	15,58
11,25	142	94	1	69945	22,22
11,50	142	94	1	25825	17,92
11,75	142	94	1	69944	23,01
12,00	151	101	1	25827	19,22
12,25	151	101	1	69943	24,41
12,50	151	101	1	25829	21,39
12,75	151	101	1	69941	25,49
13,00	151	101	1	25831	21,70
14,00	160	108	1	81564	23,22

Expo
1021

BROCA UNIVERSAL COBALTO MULTI INOX

Multi-STAINLESS Cobalt Universal Drill Bit
Foret universel cobalt Multi INOX



Cuartos / Quarters / Quarts

∅	1	1,5	2	2,5	3	3,25
Pcs	10	10	10	10	10	10
∅	3,5	4	4,25	4,5	5	
Pcs	10	10	10	10	10	
∅	5,5	6	6,5	7		
Pcs	10	10	10	10		
∅	7,5	8	8,5	9		
Pcs	10	10	10	10		
∅	9,5	10	11	12	13	
Pcs	5	5	2	2	2	

Nº Art. 57527: **976,89 €**

Previos Roscado / Before Threading / Pré-Tarudage

∅	1	1,5	2	2,5	3	3,3
Pcs	10	10	10	10	10	10
∅	3,5	4	4,2	4,5	5	
Pcs	10	10	10	10	10	
∅	5,5	6	6,5	6,8		
Pcs	10	10	10	10		
∅	7	7,5	8	8,5		
Pcs	10	10	10	10		
∅	9	9,5	10	10,2	11	12
Pcs	10	5	5	2	2	2

Nº Art. 57981: **1.064,50 €**

Línea 1m
1021

BROCA UNIVERSAL COBALTO MULTI INOX

Multi-STAINLESS Cobalt Universal Drill Bit
Foret universel cobalt Multi INOX



Cuartos / Quarters / Quarts

1,5 10	3	4	5	6	7	8	9	10	12	mm pcs
	10	10	10							
1 10	2,5	3,5	4,5	5,5	6,5	7,5	8,5	9,5	11	13
	10	10	10							

Nº Art. 71647: **976,89 €**

Previos Roscado / Before Threading / Pré-Tarudage

1,5 10	3	4	5	6	7	8	9,5	10,2	12	mm pcs
	10	10	10				5			
1 10	2,5	3,5	4,5	5,5	6,8	7,5	9	10	11	13
	10	10	10				10			

Nº Art. 71648: **1.064,50 €**

Cabinet 1021

BROCA UNIVERSAL COBALTO MULTI INOX

Multi-STAINLESS Cobalt Universal Drill Bit

Foret universel cobalt Multi INOX



176 Pcs

∅	1	1,5	2	2,5	3	3,5	4	4,5
Pcs	10	10	10	10	10	10	10	10
∅	5	5,5	6	6,5	7			
Pcs	10	10	10	10	10			
∅	7,5	8	8,5	9				
Pcs	10	10	5	5				
∅	9,5	10	10,5	11				
Pcs	5	5	1	1				
∅	11,5	12	12,5	13				
Pcs	1	1	1	1				

N° Art. 55448: **836,51 €**



Ref. **1004**

BROCA UNIVERSAL COBALTO MULTI INOX

Multi-STAINLESS Cobalt Universal Drill Bit
Foret universel cobalt Multi INOX



BOROA



Aceros <850 N/mm ² Steel / Aciers	INOX Stainless Steel Acier INOX	Cobre Copper Cuivre	Aluminio Aluminium
---	--	----------------------------------	------------------------------



D mm	L mm	I mm		Nº Art.	€
1,00	34	12	2	55605	5,65 *
1,50	40	18	2	55606	5,38 *
2,00	49	24	2	34051	5,38 *
2,50	57	30	2	34052	4,89 *
3,00	61	33	2	34053	4,78 *
3,25	65	36	2	34054	5,66 *
3,30	65	36	2	39917	5,66 *
3,50	70	39	2	34055	5,58 *
4,00	75	43	2	34056	6,02 *
4,20	75	43	1	39918	3,38
4,25	75	43	1	34057	3,38
4,50	80	47	1	34058	3,38
5,00	86	52	1	34059	3,60
5,50	93	57	1	34060	4,55
6,00	93	57	1	34061	4,85

D mm	L mm	I mm		Nº Art.	€
6,50	101	63	1	34062	5,47
6,80	109	69	1	39919	6,40
7,00	109	69	1	34063	5,96
7,50	109	69	1	34064	6,35
8,00	117	75	1	34065	7,45
8,50	117	75	1	34066	7,77
9,00	125	81	1	34067	9,89
9,50	125	81	1	72629	10,23
10,00	133	87	1	34068	11,00
10,20	133	87	1	39920	14,83
10,50	133	87	1	74942	14,83
11,00	142	94	1	34069	16,34
11,50	142	94	1	74943	18,82
12,00	151	101	1	34070	20,18
13,00	151	101	1	34071	22,78

* € = 2 uds.



Línea 1m
1004

BROCA UNIVERSAL COBALTO MULTI INOX

Multi-STAINLESS Cobalt Universal Drill Bit
Foret universel cobalt Multi INOX



ø	1	1,5	2	2,5	3	3,25	3,5	4	4,25	4,5	5	5,5	6	6,5	7	7,5	8	9	10
Pcs	3	3	5	5	10	5	5	10	5	5	10	5	10	5	5	3	5	3	3

Ref. 4995 - Nº Art. 70933: 565,79 €

Display 62



BROCA UNIVERSAL COBALTO MULTI INOX

Multi-STAINLESS Cobalt Universal Drill Bit

Foret universel cobalt Multi INOX

∅	7,5	8	8,5	9	10	11	12	13		
Pcs	3	5	3	3	3	2	2	2		
∅	4,25	4,25	4,5	5	5	5,5	6	6	6,5	7
Pcs	3	2	5	3	2	5	3	2	5	5
∅	2	2,5	2,5	3	3	3,25	3,5	3,5	4	4
Pcs	5	3	2	3	2	5	3	2	3	2

Ref. 4995 - N° Art. 34377: 578,40 €

Display 50



BROCA UNIVERSAL COBALTO MULTI INOX + PREVIOS ROSCADO

Multi-STAINLESS Cobalt Universal Drill Bit + Before Threading

Foret universel cobalt Multi INOX + Pré-Taraudage

∅	8	8,5	9	10	10,2	11	12	13		
Pcs	5	3	3	3	2	2	2	2		
∅	4,25	4,5	5	5	5,5	6	6,5	6,8	7	7,5
Pcs	5	5	3	2	5	5	5	5	5	3
∅	2	2,5	3	3	3,25	3,3	3,5	4	4	4,2
Pcs	5	5	3	2	5	5	5	3	2	3

Ref. 4995 - N° Art. 55633: 678,48 €

Display 52 Mixto PRO



BROCAS MULTI INOX + PARED PRO + MADERA PRO

Multi-Stainless + Concrete Pro + Wood Pro Drill Bits

Forets Multi INOX + Béton Pro + Bois Pro

Ref. 1886	∅	3	4	5	6	7	8	9	10	12	14
	Pcs	5	5	10	10	5	5	3	3	3	3
Ref. 1641	∅	3	3	4	4	5	5	6	6	8	10
	Pcs	3	2	3	2	3	2	3	2	5	5
Ref. 1004	∅	1	2	3	3,5	4	4,5	5	6	8	10
	Pcs	2	2	3	3	5	5	5	5	5	3

Ref. 4995 - N° Art. 68575: 463,36 €

Sets 1021

BROCA UNIVERSAL COBALTO MULTI INOX

Multi-STAINLESS Cobalt Universal Drill Bit
Foret universel cobalt Multi INOX



Set **1462**

6 Pcs

Cont. Ø	Nº Art.	€
2 - 3 - 4 - 5 - 6 - 8 mm	34204	22,37



Set **1459**

29 Pcs

Cont. Ø	Nº Art.	€
1 - 13 x 0,5 mm *	15114	228,70

* + Previos Roscado / Before Threading
Pré-Taroudage (3,3 - 4,2 - 6,8 - 10,2 mm)



Set **1466**

19 Pcs

Cont. Ø	Nº Art.	€
1 - 10 x 0,5 mm	34201	93,06

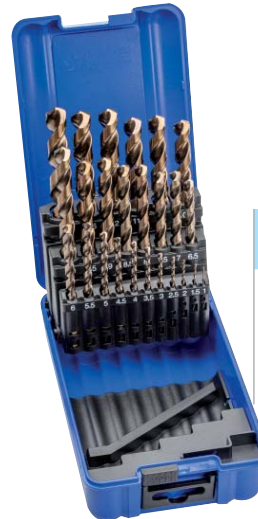

Set **1456**

25 Pcs

Cont. Ø	Nº Art.	€
1 - 13 x 0,5 mm	34199	203,72



Box-Pallet
1021

5 Sets 1466

Nº Art.	Cont. Set	€
80669	1 - 10 x 0,5 mm	442,05



Box-Pallet
1021

5 Sets 1456

Nº Art.	Cont. Set	€
80684	1 - 13 x 0,5 mm	967,65

Ref. **1016**

BROCA MANGO CILÍNDRICO COBALTO

Cobalt Straight Shank Drill Bit
Foret queue cylindrique Cobalt



PROFESSIONAL

HSSE
5% Co

DIN
338 N



Materiales Duros
Hard Materials
Matériaux durs

Aceros
<1300 N/mm²
Steel / Aciers

INOX Ferríticos-Martensíticos
Ferritic-Martensitic Stainless
INOX Ferritiques-Martensitiques

Titanio
Titanium
Titane



D mm	L mm	I mm		Nº Art.	€
0,50	22	6	10	37442	1,81
0,60	27	7	10	37443	2,31
0,70	28	9	10	37444	2,31
0,75	28	9	10	37445	1,65
0,80	30	10	10	37446	1,73
0,90	32	11	10	37447	1,73
1,00	34	12	10	27309	1,33
1,10	36	14	10	20107	1,64
1,20	38	16	10	28861	1,63
1,25	38	16	10	20112	1,58
1,30	38	16	10	20116	1,63
1,40	40	18	10	20125	1,63
1,50	40	18	10	27170	1,28
1,60	43	20	10	20133	1,63
1,70	43	20	10	20142	1,63
1,75	46	22	10	20146	1,58
1,80	46	22	10	20151	1,63
1,90	46	22	10	20155	1,63
2,00	49	24	10	19247	1,32
2,10	49	24	10	20161	1,56
2,20	53	27	10	20166	1,56
2,25	53	27	10	20170	1,49
2,30	53	27	10	20175	1,56
2,40	57	30	10	20184	1,56
2,50	57	30	10	19251	1,21
2,60	57	30	10	20199	1,51
2,65	57	30	10	80109	1,51
2,70	61	33	10	20203	1,51
2,75	61	33	10	19262	1,49
2,80	61	33	10	20209	1,51
2,90	61	33	10	20214	1,51
3,00	61	33	10	19256	1,19

D mm	L mm	I mm		Nº Art.	€
3,05	65	36	10	79847	1,61
3,10	65	36	10	20220	1,44
3,15	65	36	10	79848	1,61
3,20	65	36	10	20224	1,44
3,25	65	36	10	19259	1,44
3,30	65	36	10	20230	1,44
3,40	70	39	10	20235	1,51
3,50	70	39	10	19268	1,43
3,60	70	39	10	20241	1,81
3,70	70	39	10	20245	1,81
3,75	70	39	10	19269	1,69
3,80	75	43	10	20251	1,81
3,90	75	43	10	20256	1,81
4,00	75	43	10	19286	1,52
4,05	75	43	10	18949	1,90
4,10	75	43	10	20265	1,69
4,15	75	43	10	65326	1,90
4,20	75	43	10	20269	1,69
4,25	75	43	10	19271	1,69
4,30	80	47	10	20278	1,81
4,40	80	47	10	20283	1,81
4,50	80	47	10	19274	1,75
4,60	80	47	10	20289	2,01
4,70	80	47	10	20293	2,01
4,75	80	47	10	20298	1,90
4,80	86	52	10	20302	2,01
4,90	86	52	10	20311	2,01
5,00	86	52	10	19277	1,83
5,05	86	52	10	76128	2,44
5,10	86	52	10	20320	2,18
5,15	86	52	10	79849	2,44
5,20	86	52	10	20328	2,18

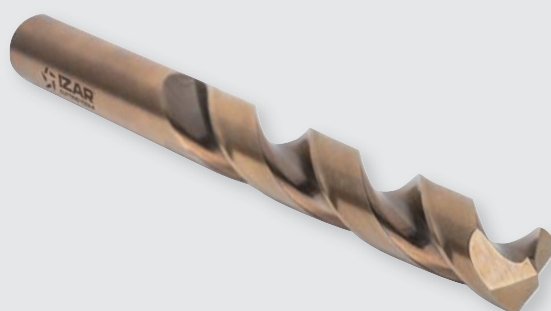





Ref. **1016**

BROCA MANGO CILÍNDRICO COBALTO

Cobalt Straight Shank Drill Bit
Foret queue cylindrique Cobalt

D mm	L mm	I mm		Nº Art.	€	D mm	L mm	I mm		Nº Art.	€
5,25	86	52	10	19280	2,16	9,80	133	87	10	26809	8,93
5,30	86	52	10	20340	2,18	9,90	133	87	10	27121	8,93
5,40	93	57	10	20349	2,18	10,00	133	87	10	27291	6,11
5,50	93	57	10	19290	2,31	10,10	133	87	5	27318	10,25
5,60	93	57	10	20361	2,75	10,20	133	87	5	27541	8,65
5,70	93	57	10	20370	2,75	10,25	133	87	5	27544	10,64
5,75	93	57	10	20379	2,60	10,30	133	87	5	27585	10,25
5,80	93	57	10	20388	2,75	10,40	133	87	5	27682	10,25
5,90	93	57	10	20397	2,75	10,50	133	87	5	27685	8,65
6,00	93	57	10	19301	2,48	10,60	133	87	5	27690	11,93
6,05	101	63	10	79855	3,43	10,70	142	94	5	27693	11,93
6,10	101	63	10	20415	3,06	10,75	142	94	5	27696	12,38
6,15	101	63	10	79856	3,43	10,80	142	94	5	27699	11,93
6,20	101	63	10	20424	3,06	10,90	142	94	5	27702	11,93
6,25	101	63	10	20433	2,89	11,00	142	94	5	27705	9,56
6,30	101	63	10	20442	3,06	11,10	142	94	5	27708	13,58
6,35	101	63	10	79858	3,06	11,20	142	94	5	27711	13,58
6,40	101	63	10	20451	3,06	11,25	142	94	5	27714	14,09
6,45	101	63	10	64140	3,06	11,30	142	94	5	27717	13,58
6,50	101	63	10	27290	2,95	11,40	142	94	5	27720	13,58
6,60	101	63	10	20466	3,67	11,50	142	94	5	19307	11,42
6,70	101	63	10	20475	3,67	11,60	142	94	5	27724	14,04
6,75	109	69	10	20481	3,45	11,70	142	94	5	27727	14,04
6,80	109	69	10	20488	3,45	11,75	142	94	5	27730	14,58
6,90	109	69	10	20493	3,67	11,80	142	94	5	27733	14,04
7,00	109	69	10	19305	3,23	11,90	151	101	5	27736	14,04
7,10	109	69	10	20499	4,67	12,00	151	101	5	19311	12,21
7,20	109	69	10	20503	4,67	12,10	151	101	5	27742	16,28
7,25	109	69	10	20508	4,39	12,20	151	101	5	27745	16,28
7,30	109	69	10	20512	4,67	12,25	151	101	5	19313	16,90
7,40	109	69	10	20517	4,67	12,30	151	101	5	27749	16,28
7,50	109	69	10	19292	3,45	12,40	151	101	5	27752	16,28
7,60	117	75	10	20523	5,64	12,50	151	101	5	27755	14,88
7,70	117	75	10	20527	5,64	12,60	151	101	5	27758	16,99
7,75	117	75	10	20532	5,32	12,70	151	101	5	27761	16,99
7,80	117	75	10	20536	5,64	12,75	151	101	5	19316	17,66
7,90	117	75	10	20541	5,64	12,80	151	101	5	27765	16,99
8,00	117	75	10	20208	4,04	12,90	151	101	5	27768	16,99
8,10	117	75	10	22734	5,38	13,00	151	101	5	27771	15,24
8,20	117	75	10	22737	5,38	13,25	160	108	1	27777	21,05
8,25	117	75	10	22740	5,08	13,50	160	108	1	27774	16,77
8,30	117	75	10	22743	5,38	13,75	160	108	1	27780	21,05
8,40	117	75	10	22746	5,38	14,00	160	108	1	27783	16,59
8,50	117	75	10	19298	4,19	14,25	169	114	1	27786	27,68
8,60	125	81	10	22752	6,85	14,50	169	114	1	27789	23,52
8,70	125	81	10	22755	6,85	14,75	169	114	1	27792	27,68
8,75	125	81	10	22758	6,47	15,00	169	114	1	27795	23,89
8,80	125	81	10	22761	6,85	15,25	178	120	1	27798	38,20
8,90	125	81	10	22764	6,85	15,50	178	120	1	27801	27,65
9,00	125	81	10	20358	5,35	15,75	178	120	1	27804	38,20
9,10	125	81	10	22768	7,59	16,00	178	120	1	27807	28,65
9,20	125	81	10	22771	7,59	16,50	184	125	1	27811	32,74
9,25	125	81	10	22774	7,14	17,00	184	125	1	27814	32,74
9,30	125	81	10	22777	7,59	17,50	191	130	1	27817	36,29
9,40	125	81	10	22780	7,59	18,00	191	130	1	27820	39,51
9,50	125	81	10	20545	5,56	18,50	198	135	1	27823	43,65
9,60	133	87	10	22784	8,93	19,00	198	135	1	27826	43,65
9,70	133	87	10	23567	8,93	19,50	205	140	1	27829	48,39
9,75	133	87	10	26697	8,42	20,00	205	140	1	27832	51,84

Expo
1016

BROCA MANGO CILÍNDRICO COBALTO

Cobalt Straight Shank Drill Bit
Foret queue cylindrique Cobalt



Cuartos / Quarters / Quarts

Ø	1	1,5	2	2,5	3	3,25
Pcs	10	10	40	10	40	10
Ø	3,5	4	4,25	4,5	5	
Pcs	10	40	10	10	40	
Ø	5,5	6	6,5	7		
Pcs	10	40	10	10		
Ø	7,5	8	8,5	9		
Pcs	10	30	10	10		
Ø	9,5	10	11	12	13	
Pcs	10	10	5	5	5	

Nº Art. 57525: **1.072,65 €**

Previos Roscado / Before Threading / Pré-Taraudage

Ø	1	1,5	2	2,5	3	3,3
Pcs	10	10	40	10	40	10
Ø	3,5	4	4,2	4,5	5	
Pcs	10	40	10	10	40	
Ø	5,5	6	6,5	6,8		
Pcs	10	40	10	10		
Ø	7	7,5	8	8,5		
Pcs	10	10	30	10		
Ø	9	9,5	10	10,2	11	12
Pcs	10	10	10	5	5	5

Nº Art. 57978: **1.150,43 €**

Línea 1m
1016

BROCA MANGO CILÍNDRICO COBALTO

Cobalt Straight Shank Drill Bit
Foret queue cylindrique Cobalt



Cuartos / Quarters / Quarts

1,5 10	3	4	5	6 40	7 10	8 30	9 10	10 10	12 5	mm pcs
	2,5 10	3,5 10	4,5 10							
1 10	2 40	3,25 10	4,25 10	5,5 10	6,5 10	7,5 10	8,5 10	9,5 10	11 5	13 5

Nº Art. 71642: **1.072,65 €**

Previos Roscado / Before Threading / Pré-Taraudage

1,5 10	3	4	5	6 40	7 10	8 30	9,5 10	10,2 5	12 5	mm pcs
	2,5 10	3,5 10	4,5 10				9 10			
1 10	2 40	3,3 10	4,2 10	5,5 10	6,5 10	7,5 10	8,5 10	10 10	11 5	13 5

Nº Art. 71643: **1.150,43 €**

Cabinet 1016

BROCA MANGO CILÍNDRICO COBALTO

Cobalt Straight Shank Drill Bit
Foret queue cylindrique Cobalt



220 Pcs

∅	1	1,5	2	2,5	3	3,5	4	4,5
Pcs	10	10	10	10	10	10	10	10
∅	5	5,5	6	6,5	7			
Pcs	10	10	10	10	10			
∅	7,5	8	8,5	9				
Pcs	10	10	10	10				
∅	9,5	10	10,5	11				
Pcs	10	10	5	5				
∅	11,5	12	12,5	13				
Pcs	5	5	5	5				

Nº Art. 55449: **885,18 €**

Ref. **1006**

BROCA MANGO CILÍNDRICO COBALTO

Cobalt Straight Shank Drill Bit
Foret queue cylindrique Cobalt



PROFESSIONAL

HSSE
5% Co

DIN
338 N



Materiales Duros
Hard Materials
Matériaux durs

Aceros
<1300 N/mm²
Steel / Aciers

INOX Ferríticos-Martensíticos
Ferritic-Martensitic Stainless
INOX Ferritiques-Martensitiques

Titanio
Titanium
Titane



D mm	L mm	I mm		Nº Art.	€
1,00	34	12	2	30163	3,12 *
1,50	40	18	2	30164	2,98 *
2,00	49	24	2	18480	3,08 *
2,50	57	30	2	30165	2,80 *
2,80	61	33	2	79615	3,42 *
3,00	61	33	2	18481	2,68 *
3,25	65	36	2	30166	3,24 *
3,30	65	36	2	34035	3,24 *
3,50	70	39	2	30167	3,21 *
3,80	75	43	2	79616	4,10 *
4,00	75	43	2	18483	3,45 *
4,20	75	43	1	34036	1,91
4,25	75	43	1	30168	1,91
4,50	80	47	1	30169	1,97
4,80	86	52	1	79617	2,29
5,00	86	52	1	18484	2,06
5,50	93	57	1	30170	2,62
6,00	93	57	1	18486	2,69
6,50	101	63	1	30171	3,21
6,80	109	69	1	34037	3,78
7,00	109	69	1	18487	3,51
7,50	109	69	1	30172	3,77
8,00	117	75	1	18489	4,41
8,50	117	75	1	30162	4,61
9,00	125	81	1	18490	5,85
9,50	125	81	1	66997	5,89
10,00	133	87	1	18492	6,48
10,20	133	87	1	34038	9,16
10,50	133	87	1	66998	9,16
11,00	142	94	1	30161	10,12
11,50	142	94	1	66999	12,11
12,00	151	101	1	18493	12,96
12,50	151	101	1	67000	15,78
13,00	151	101	1	30160	16,16
14,00	160	108	1	79618	17,60
15,00	169	114	1	79619	25,35

* € = 2 uds.

Línea 1m
1006

BROCA MANGO CILÍNDRICO COBALTO

Cobalt Straight Shank Drill Bit
Foret queue cylindrique Cobalt



∅	1	1,5	2	2,5	3	3,25	3,5	4	4,25	4,5	5	5,5	6	6,5	7	7,5	8	9	10	
Pcs	5	5	10	5	10	5	10	10	10	10	10	10	10	10	10	10	10	10	10	10

Ref. 4995 - Nº Art. 70936: 569,89 €

Display
13

BROCA MANGO CILÍNDRICO COBALTO

Cobalt Straight Shank Drill Bit
Foret queue cylindrique Cobalt



∅	7,5	8	8,5	9	10	11	12	13		
Pcs	5	5	5	5	5	3	3	3		
∅	4	4,25	4,5	5	5	5,5	6	6	6,5	7
Pcs	5	10	5	5	5	5	5	5	5	5
∅	1	1,5	2	2,5	3	3	3,25	3,5	3,5	4
Pcs	5	5	10	5	5	5	10	5	5	5

Ref. 4995 - Nº Art. 22181: 567,67 €

Display
48

BROCA MANGO CILÍNDRICO COBALTO + PREVIOS ROSCADO

Cobalt Straight Shank Drill Bit + Before Threading
Foret Queue Cylindrique Cobalt + Pré-Taraudage



∅	8	8,5	9	10	10,2	11	12	13		
Pcs	5	5	5	5	3	3	3	3		
∅	4,25	4,5	5	5	5,5	6	6,5	6,8	7	7,5
Pcs	5	5	5	5	5	10	5	5	5	5
∅	1	1,5	2	2,5	3	3,25	3,3	3,5	4	4,2
Pcs	5	5	5	5	10	5	5	10	10	5

Ref. 4995 - Nº Art. 55621: 598,66 €

Sets 1016

BROCA MANGO CILÍNDRICO COBALTO

Cobalt Straight Shank Drill Bit
Foret queue cylindrique Cobalt



Set **1462**

6 Pcs

Cont. Ø	Nº Art.	€
2 - 3 - 4 - 5 - 6 - 8 mm	30231	13,19



Set **1459**

29 Pcs

Cont. Ø	Nº Art.	€
1 - 13 x 0,5 mm *	15073	142,43

* + Previos Roscado / Before Threading
Pré-Taroudage (3,3 - 4,2 - 6,8 - 10,2 mm)



Set **1466**

19 Pcs

Cont. Ø	Nº Art.	€
1 - 10 x 0,5 mm	25274	54,79

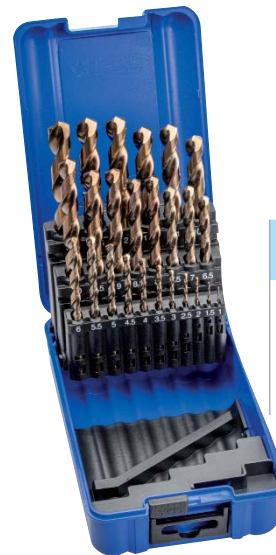

Set **1456**

25 Pcs

Cont. Ø	Nº Art.	€
1 - 13 x 0,5 mm	18370	127,47



Box-Pallet
1016

5 Sets 1466

Nº Art.	Cont. Set	€
80664	1 - 10 x 0,5 mm	260,26



Box-Pallet
1016

5 Sets 1456

Nº Art.	Cont. Set	€
80680	1 - 13 x 0,5 mm	605,51

Display
24

SETS BROCAS MANGO CILINDRICO HSS + HSSE

HSS + HSSE Straight Shank Drill Bit Sets
Jeux Forets Queue Cylindrique HSS + HSSE



HSSE	Ref. 1462 - 1016 Metal Pro 5 Pcs.	Ref. 1466 - 1016 Metal Pro 19 Pcs.	Ref. 1456 - 1016 Metal Pro 25 Pcs.
	Pcs 5	1	1
HSS	Ref. 1462 - 1010 Metal 5 Pcs.	Ref. 1466 - 1010 Metal 19 Pcs.	Ref. 1456 - 1010 Metal 25 Pcs.
	Pcs 5	2	2

Ref. 4995 - N° Art. 22320: 487,46 €

Sets
1016

BROCA MANGO CILÍNDRICO COBALTO

Cobalt Straight Shank Drill Bit
Foret queue cylindrique Cobalt

Set 1407



37 Pcs

Set 1409



49 Pcs

Set 1405



50 Pcs

Cont. Ø	N° Art.	€
1 - 10 x 0,25 mm	18367	140,20

Cont. Ø	N° Art.	€
1 - 13 x 0,25 mm	18369	300,43

Cont. Ø	N° Art.	€
1 - 5,9 x 0,1 mm	10788	97,92

Sets 1016

BROCA MANGO CILÍNDRICO COBALTO

Cobalt Straight Shank Drill Bit
Foret queue cylindrique Cobalt

Set **1408**



41 Pcs

Cont. Ø	Nº Art.	€
6 - 10 x 0,1 mm	18366	237,86

Set **1406**



* Base roja / Red base / Base rouge

91 Pcs

Cont. Ø	Nº Art.	€
1-10 x 0,10 mm	56686	334,70

Set **1470**



170
Pcs

220
Pcs

Cont. Ø	Nº Art.	€
1-10 x 0,5 mm Ø 1-8: 10 pcs/Ø Ø 8,5-10: 5 pcs/Ø	10676	430,50
1-13 x 0,5 + 3,3 + 4,2 mm Ø 1-8: 10 pcs/Ø Ø 8,5-13: 5 pcs/Ø	25391	854,77



Ref. **1020**

BROCA MANGO CILÍNDRICO COBALTO INOX

STAINLESS Cobalt Straight Shank Drill Bit
Foret queue cylindrique Cobalt INOX



SPEED MAX

INOX
Stainless Steel
Acier INOX
Aluminio
Aluminium



D mm	L mm	I mm		Nº Art.	€
1,00	34	12	10	14115	1,96
1,25	38	16	10	14116	2,32
1,50	40	18	10	14117	1,86
2,00	49	24	10	21615	1,86
2,10	49	24	10	13961	2,16
2,20	53	27	10	13962	2,16
2,25	53	27	10	21616	2,05
2,30	53	27	10	13963	2,16
2,40	57	30	10	13965	2,16
2,50	57	30	10	21618	1,69
2,60	57	30	10	13966	2,16
2,70	61	33	10	13968	2,16
2,75	61	33	10	21625	2,05
2,80	61	33	10	12964	2,22
2,90	61	33	10	13969	2,22
3,00	61	33	10	16283	1,66
3,10	65	36	10	17970	2,04
3,20	65	36	10	16284	2,04
3,25	65	36	10	16285	2,04
3,30	65	36	10	16286	2,04
3,40	70	39	10	13971	2,22
3,50	70	39	10	16287	2,02
3,60	70	39	10	13972	2,66
3,70	70	39	10	14120	2,66
3,75	70	39	10	16288	2,41
3,80	75	43	10	12507	2,66
3,90	75	43	10	13974	2,66
4,00	75	43	10	16289	2,16
4,10	75	43	10	16290	2,41
4,20	75	43	10	16291	2,41
4,25	75	43	10	16292	2,41
4,30	80	47	10	14122	2,66
4,40	80	47	10	13975	2,66
4,50	80	47	10	16293	2,41
4,60	80	47	10	13979	2,82
4,70	80	47	10	13981	2,82
4,75	80	47	10	16294	2,68
4,80	86	52	10	14123	2,96
4,90	86	52	10	13983	2,96
5,00	86	52	10	16295	2,59
5,10	86	52	10	16296	3,06
5,20	86	52	10	28626	3,20
5,25	86	52	10	16297	3,02
5,30	86	52	10	13984	3,07
5,40	93	57	10	13986	3,07
5,50	93	57	10	16298	3,27

D mm	L mm	I mm		Nº Art.	€
5,60	93	57	10	13987	4,03
5,70	93	57	10	25134	4,03
5,75	93	57	10	16299	3,64
5,80	93	57	10	13989	4,03
5,90	93	57	10	13991	4,03
6,00	93	57	10	16302	3,47
6,10	101	63	10	13993	4,25
6,20	101	63	10	13994	4,25
6,25	101	63	10	21627	3,99
6,30	101	63	10	14002	4,25
6,40	101	63	10	14003	4,25
6,50	101	63	10	16304	4,05
6,60	101	63	10	14004	5,06
6,70	101	63	10	14005	5,06
6,75	109	69	10	21628	4,76
6,80	109	69	10	16306	4,76
6,90	109	69	10	14006	5,06
7,00	109	69	10	16307	4,42
7,10	109	69	10	14007	6,37
7,20	109	69	10	14008	6,37
7,25	109	69	10	21631	6,07
7,30	109	69	10	14009	6,37
7,40	109	69	10	14010	6,37
7,50	109	69	10	16309	4,73
7,60	117	75	10	14011	7,71
7,70	117	75	10	14012	7,71
7,75	117	75	10	69940	7,28
7,80	117	75	10	14013	7,71
7,90	117	75	10	14014	7,71
8,00	117	75	10	16311	5,52
8,10	117	75	5	14015	7,35
8,20	117	75	5	14016	7,35
8,25	117	75	5	21633	7,01
8,30	117	75	5	14017	7,35
8,40	117	75	5	14018	7,35
8,50	117	75	5	16313	5,77
8,60	125	81	5	14019	9,44
8,70	125	81	5	14020	9,44
8,75	125	81	5	69938	8,84
8,80	125	81	5	14021	9,44
8,90	125	81	5	14022	9,44
9,00	125	81	5	16314	7,33
9,10	125	81	5	14023	10,25
9,20	125	81	5	14024	10,25
9,25	125	81	5	69937	9,78
9,30	125	81	5	14025	10,25

D mm	L mm	I mm		Nº Art.	€
9,40	125	81	5	14026	10,25
9,50	125	81	5	16316	7,60
9,60	133	87	5	14027	12,22
9,70	133	87	5	14028	12,22
9,75	133	87	5	69935	11,52
9,80	133	87	5	14029	12,22
9,90	133	87	5	14060	12,22
10,00	133	87	5	16318	8,39
10,10	133	87	5	14064	13,94
10,20	133	87	5	14248	11,30
10,25	133	87	5	21634	14,72
10,30	133	87	5	74568	13,94
10,40	133	87	5	74567	13,94
10,50	133	87	5	16320	11,30
10,60	133	87	5	74566	16,44
10,70	142	94	5	74565	16,44
10,75	142	94	5	69934	16,22
10,80	142	94	5	14249	16,44
10,90	142	94	5	74564	16,44
11,00	142	94	5	16321	12,48
11,10	142	94	5	30587	18,19
11,20	142	94	5	14250	18,19
11,25	142	94	5	69932	17,78
11,30	142	94	5	74563	18,19
11,40	142	94	5	74562	18,27
11,50	142	94	5	16322	14,36
11,60	142	94	5	74561	18,82
11,70	142	94	5	74560	18,82
11,75	142	94	5	69931	18,40
11,80	142	94	5	14252	18,82
11,90	151	101	5	74559	18,82
12,00	151	101	5	16323	15,41
12,10	151	101	5	74558	19,76
12,20	151	101	5	14276	19,76
12,25	151	101	5	69929	19,52
12,30	151	101	5	74557	19,76
12,40	151	101	5	74556	19,76
12,50	151	101	5	16324	17,14
12,60	151	101	5	74554	20,62
12,70	151	101	5	74553	20,62
12,75	151	101	5	69928	20,40
12,80	151	101	5	14288	20,62
12,90	151	101	5	74552	20,62
13,00	151	101	5	16325	17,40

Expo
1020

BROCA MANGO CILÍNDRICO COBALTO INOX

STAINLESS Cobalt Straight Shank Drill Bit

Foret queue cylindrique Cobalt INOX



Cuartos / Quarters / Quarts

∅	1	1,5	2	2,5	3	3,25
Pcs	10	10	20	10	20	10
∅	3,5	4	4,25	4,5	5	
Pcs	20	20	10	10	20	
∅	5,5	6		6,5	7	
Pcs	10	20		10	10	
∅	7,5	8		8,5	9	
Pcs	10	10		5	10	
∅	9,5	10	11	12	13	
Pcs	5	5	5	5	5	

Nº Art. 57526: **1.027,46 €**

Previos Roscado / Before Threading / Pré-Taradage

∅	1	1,5	2	2,5	3	3,3
Pcs	10	10	20	10	20	10
∅	3,5	4	4,2	4,5	5	
Pcs	20	20	10	10	20	
∅	5,5	6		6,5	6,8	
Pcs	10	20		10	10	
∅	7	7,5	8	8,5		
Pcs	10	10	10	5		
∅	9	9,5	10	10,2	11	12
Pcs	10	5	5	5	5	5

Nº Art. 57979: **1.131,56 €**

Línea 1m
1020

BROCA MANGO CILÍNDRICO COBALTO INOX

STAINLESS Cobalt Straight Shank Drill Bit

Foret queue cylindrique Cobalt INOX



Cuartos / Quarters / Quarts

1,5	3	4	5	6	7	8	9	10	12	mm pcs
20	20	20	20	20	10	10	10	5	5	
10	2,5	3,5	4,5	5,5	6,5	7,5	8,5	9,5	11	13
10	10	20	10							

Nº Art. 71644: **1.027,46 €**

Previos Roscado / Before Threading / Pré-Taradage

1,5	3	4	5	6	7	8	9,5	10,2	12	mm pcs
20	20	20	20	20	10	10	5			
10	2,5	3,5	4,5	5,5	6,8	7,5	9	10	11	13
10	10	20	10							
10	2	3,3	4,2	5,5	6,5	7,5	8,5	10	11	13
	20	10	10	10	10	10	5	5	5	5

Nº Art. 71646: **1.131,56 €**

Cabinet 1020

BROCA MANGO CILÍNDRICO COBALTO INOX

STAINLESS Cobalt Straight Shank Drill Bit

Foret queue cylindrique Cobalt INOX



200 Pcs

∅	1	1,5	2	2,5	3	3,5	4	4,5
Pcs	10	10	10	10	10	10	10	10
∅	5	5,5	6	6,5	7			
Pcs	10	10	10	10	10			
∅	7,5	8	8,5	9				
Pcs	10	10	5	5				
∅	9,5	10	10,5	11				
Pcs	5	5	5	5				
∅	11,5	12	12,5	13				
Pcs	5	5	5	5				

Nº Art. 55446: **1.022,65 €**

Ref. **1005**

BROCA MANGO CILÍNDRICO COBALTO INOX

STAINLESS Cobalt Straight Shank Drill Bit
Foret queue cylindrique Cobalt INOX



SPEED MAX



INOX
Stainless Steel
Acier INOX

Aluminio
Aluminium



D mm	L mm	I mm		Nº Art.	€
1,00	34	12	2	70000	4,41 *
1,50	38	16	2	70001	4,21 *
2,00	49	24	2	24757	4,33 *
2,50	57	30	2	24758	3,94 *
3,00	61	33	2	24759	3,84 *
3,25	65	36	2	24760	4,55 *
3,30	65	36	2	55632	4,55 *
3,50	70	39	2	24761	4,47 *
4,00	75	43	2	24762	4,82 *
4,20	75	43	1	55635	2,69
4,25	75	43	1	24763	2,69
4,50	80	47	1	24764	2,69
5,00	86	52	1	24765	2,88
5,50	93	57	1	24766	3,64
6,00	93	57	1	24767	3,89
6,50	101	63	1	24768	4,39
6,80	109	69	1	55636	5,14
7,00	109	69	1	24769	4,78
7,50	109	69	1	24770	5,09
8,00	117	75	1	24771	5,96
8,50	117	75	1	24772	6,22
9,00	125	81	1	24773	7,95
10,00	133	87	1	24774	8,80
10,20	133	87	1	55638	11,84
11,00	142	94	1	24775	13,09
12,00	151	101	1	24776	16,17
13,00	151	101	1	24777	18,27



* € = 2 uds.



Línea 1m
1005

BROCA MANGO CILÍNDRICO COBALTO INOX

STAINLESS Cobalt Straight Shank Drill Bit
Foret queue cylindrique Cobalt INOX



∅	1	1,5	2	2,5	3	3,25	3,5	4	4,25	4,5	5	5,5	6	6,5	7	7,5	8	9	10
Pcs	3	3	5	5	10	5	5	10	5	5	10	5	10	5	5	3	5	3	3

Ref. 4995 - Nº Art. 70940: 452,84 €

Display
16

BROCA MANGO CILÍNDRICO COBALTO INOX

STAINLESS Cobalt Straight Shank Drill Bit
Foret queue cylindrique Cobalt INOX



∅	7,5	8	8,5	9	10	11	12	13		
Pcs	5	5	5	5	3	2	2	2		
∅	4,25	4,25	4,5	5	5	5,5	6	6	6,5	7
Pcs	3	2	5	5	5	5	3	2	5	5
∅	2	2,5	2,5	3	3	3,25	3,5	3,5	4	4
Pcs	5	3	2	5	5	5	3	2	5	5

Ref. 4995 - Nº Art. 22497: 559,83 €

Display
49

BROCA MANGO CILÍNDRICO COBALTO INOX + PREVIOS ROSCADO

STAINLESS Cobalt Straight Shank Drill Bit + Before Threading
Foret queue cylindrique Cobalt INOX + Pré-Taraudage



∅	8	8,5	9	10	10,2	11	12	13		
Pcs	5	3	3	3	3	2	2	2		
∅	4,25	4,5	5	5	5,5	6	6,5	6,8	7	7,5
Pcs	5	5	5	5	5	10	5	5	5	3
∅	2	2,5	3	3	3,25	3,3	3,5	4	4	4,2
Pcs	5	5	5	5	5	5	5	5	5	5

Ref. 4995 - Nº Art. 55629: 638,21 €

Sets 1020

BROCA MANGO CILÍNDRICO COBALTO INOX

STAINLESS Cobalt Straight Shank Drill Bit
Foret queue cylindrique Cobalt INOX



Set **1462**

6 Pcs

Cont. Ø	Nº Art.	€
2 - 3 - 4 - 5 - 6 - 8 mm	25367	18,08



New!

Set **1459**

29 Pcs

Cont. Ø	Nº Art.	€
1 - 13 x 0,5 mm *	15113	184,07

* + Previos Roscado / Before Threading
Pré-Taroudage (3,3 - 4,2 - 6,8 - 10,2 mm)

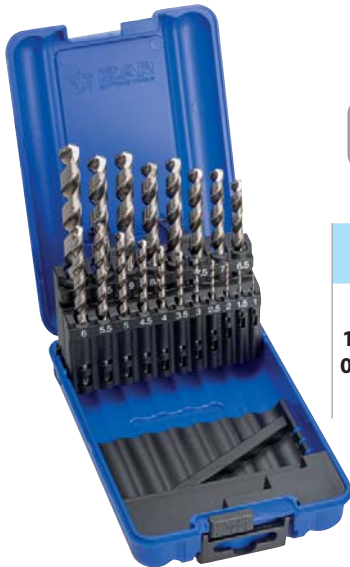

Set **1466**

19 Pcs

Cont. Ø	Nº Art.	€
1 - 10 x 0,5 mm	24636	75,01

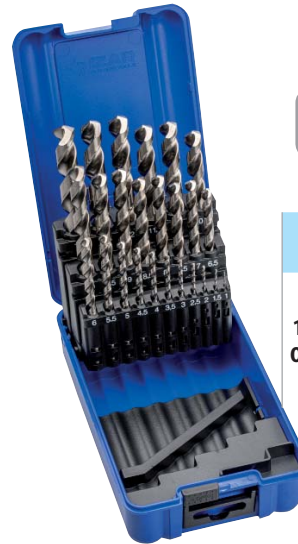

Set **1456**

25 Pcs

Cont. Ø	Nº Art.	€
1 - 13 x 0,5 mm	24638	163,83



Box-Pallet
1020

5 Sets 1466

Nº Art.	Cont. Set	€
80667	1 - 10 x 0,5 mm	356,31



Box-Pallet
1020

5 Sets 1456

Nº Art.	Cont. Set	€
80682	1 - 13 x 0,5 mm	778,21



Ref. **1027**

BROCA MANGO REBAJADO COBALTO

Cobalt Reduced Shank Drill Bit
Foret queue reduite Cobalt



HSSE
5% Co

DIN
338 N



Aceros
<1300 N/mm²
Steel / Aciers

INOX Ferríticos-Martensíticos
Ferritic-Martensitic Stainless
INOX Ferritiques-Martensitiques

Titanio
Titanium
Titane

D mm	d mm	L mm	l mm		Nº Art.	€
10,50	10,00	133	87	1	54954	11,23
11,00	10,00	142	94	1	54955	12,41
11,50	10,00	142	94	1	54956	14,86
12,00	10,00	151	101	1	22346	15,89
12,50	10,00	151	101	1	54957	19,33
13,00	10,00	151	101	1	22347	20,39
13,50	12,70	160	108	1	49200	21,82
14,00	12,70	160	108	1	22344	22,22
14,50	12,70	169	114	1	49201	30,59
15,00	12,70	169	114	1	22348	31,96
15,50	12,70	178	120	1	49223	35,94
16,00	12,70	178	120	1	22349	36,87
16,50	12,70	184	125	1	54979	42,54
17,00	12,70	184	125	1	22350	42,13
17,50	12,70	191	130	1	54958	47,18
18,00	12,70	191	130	1	22351	50,88
18,50	12,70	198	135	1	54959	56,76
19,00	12,70	198	135	1	22353	56,18
19,50	12,70	205	140	1	54960	62,93
20,00	12,70	205	140	1	22354	66,71
20,50	12,70	205	145	1	66946	70,24
21,00	12,70	205	145	1	66941	70,24
21,50	12,70	210	150	1	66945	77,48
22,00	12,70	210	150	1	66940	77,48
22,50	12,70	210	150	1	66944	84,76
23,00	12,70	210	150	1	66939	84,76
23,50	12,70	220	160	1	66943	93,54
24,00	12,70	220	160	1	66938	93,54
24,50	12,70	220	160	1	66942	101,99
25,00	12,70	220	160	1	66937	101,99

Línea 1m
1027

BROCA MANGO REBAJADO COBALTO

Cobalt Reduced Shank Drill Bit
Foret queue reduite Cobalt



∅	12	12,5	13	13,5	14	15	15,5	16	16,5	17	17,5	18	18,5	19	19,5	20
Pcs	1	1	1	1	1	1	1	1	1	1	1	1	1	1	1	1

Ref. 4995 - Nº Art. 72076: **629,72 €**

Ref. **9015**

BROCA ROMPE BOMBILLOS CERRADURAS

Cylinder Lock Breaker Drill Bit
Foret destructeur de trous de serrure



D mm	d mm	L mm	l mm	Nº Art.	€
6	6	60	34	70727	54,24



- Metal Duro monoblock de última generación
- Punta auto centrante
- Afilado especial IZAR
- Precisión y buen acabado
- Apto para bombillos de latón y acero o bombillos de seguridad.
- Last generation monoblock Solid Carbide
- Autocentering point
- IZAR special Sharpening
- Good Precision and Finishing
- Suitable for brass, steel or security cylinder locks
- Carbure monoblock dernière génération
- Pointe autocentrante
- Affûtage spéciale IZAR
- Précision et bonne qualité de finition
- Conçu pour serrure en laiton et acier ou serrure de sécurité

Ref. **9289**

FRESA MICROGRANO CERRADURAS

Lock Micrograin End Mill
Fraise micrograin serrures

New!

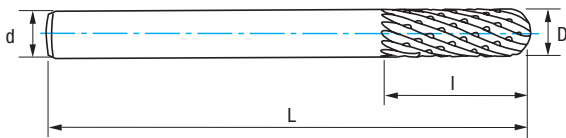

D mm	d mm	L mm	l mm	Nº Art.	€	Nº Art. ALTIN	€
3	6	60	15	53893	17,23	14935	20,85
4	6	60	15	53894	17,76	14941	21,39
6	6	60	18	53895	18,70	14944	23,93

Set **9015**

SET CERRAJEROS

Locksmith Set
Jeu serruriers

New!



4 Pcs

Cont.	Nº Art.	€
Ref. 9015: ø 6 mm Ref. 9289: ø 3-4-6 mm	53879	107,35

Ref. **9100**

BROCA MANGO CILÍNDRICO PUNTA METAL DURO

Carbide Tipped Straight Shank Drill Bit
Foret queue cylindrique pointe carbure



MD
HM
Carbure

DIN
338 N



Aceros
<1000 N/mm²
Steel / Aciers

Aceros
<1300 N/mm²
Steel / Aciers

Fundición
Cast Iron
Fonte

Titanio
Titanium
Titane

Cobre
Copper
Cuivre

Duroplásticos
Hard Plastics
Plastiques durs



D mm	L mm	I mm		Nº Art.	€	D mm	L mm	I mm		Nº Art.	€
2,00	49	24	1	71429	15,06	6,30	101	63	1	32692	20,97
2,50	57	30	1	71444	15,06	6,50	101	63	1	71558	20,97
2,70	57	30	1	46916	15,06	6,60	101	63	1	30614	20,98
3,00	61	33	1	71459	15,06	6,80	109	69	1	23893	20,98
3,10	61	33	1	46917	15,51	7,00	109	69	1	71573	20,98
3,20	65	36	1	23058	15,51	7,50	109	69	1	71585	21,81
3,30	65	36	1	26716	15,51	7,80	117	75	1	23914	21,81
3,40	70	39	1	29479	15,51	8,00	117	75	1	71600	21,81
3,50	70	39	1	71474	15,51	8,50	117	75	1	71615	23,79
3,60	70	39	1	52285	15,51	8,60	125	81	1	27007	37,01
4,00	75	43	1	71489	15,51	9,00	125	81	1	71630	23,79
4,10	75	43	1	46918	15,51	9,50	125	81	1	71645	25,99
4,20	75	43	1	22016	15,51	10,00	133	87	1	71660	25,99
4,50	80	47	1	71504	15,91	10,20	133	87	1	27008	33,49
4,60	80	47	1	26963	15,91	10,50	133	87	1	71663	33,49
4,70	80	47	1	17101	15,91	11,00	142	94	1	71666	33,49
4,80	86	52	1	26964	15,91	11,50	142	94	1	71672	38,52
5,00	86	52	1	71516	15,91	12,00	151	101	1	71675	38,52
5,10	86	52	1	23059	16,78	12,50	151	101	1	71681	46,09
5,20	86	52	1	67682	16,78	13,00	151	101	1	71684	46,09
5,50	93	57	1	71531	16,78	14,00	160	108	1	71690	53,63
5,60	93	57	1	32603	17,60	15,00	169	114	1	71696	61,16
5,70	93	57	1	23889	17,60	16,00	178	120	1	71702	70,41
5,80	93	57	1	54039	17,60	17,00	184	125	1	71705	77,09
6,00	93	57	1	71543	17,60	18,00	191	130	1	71711	82,97
6,10	101	63	1	23891	20,97	19,00	198	135	1	71717	103,08
6,20	101	63	1	32691	20,97	20,00	205	140	1	71723	117,32

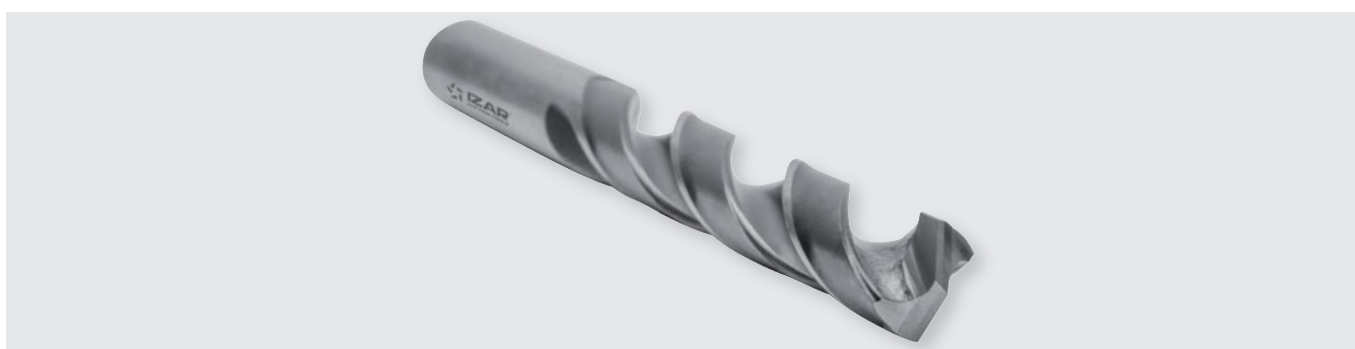

Ref.

1015

BROCA MANGO CILÍNDRICO ZIRKONIO

Zirkonio Straight Shank Drill Bit
Foret queue cylindrique ZirkonioEspecial
Multi
METAL

ZIRKON

HSS
+
ZirkonioDIN
338 N

130°

Tol. D
h8

Video

Aceros
<850 N/mm²
Steel / AciersFundición
Cast Iron
FonteAluminio
Aluminium**Angulo punta 130°**

- Autocentradora
- Ideal taladro portátil
- Geometría especial diseñada para reducir el esfuerzo de corte

130° Point Angle

- Auto-centering
- Ideal Portable Drilling Machine
- Special Geometry designed for reducing cutting effort

Angle Pointe 130°

- Autocentreur
- Perçuse à main
- Géométrie pour réduire l'effort de coupe

Nuevo recubrimiento Zirkonio de última generación por PVD

- Basado en ZRN
- Bajo coeficiente de fricción
- Muy resistente a la corrosión
- Adecuado para materiales no férricos
- Evita la adherencia de material en el filo de corte

Latest generation Zirkonio coating by PVD

- Based on ZRN
- Low Friction Coefficient
- High Corrosion Resistant
- Appropriate for Non-Ferrous Materials
- Built-Up Edge avoided

Nouveau revêtement Zirkonio dernière génération par PVD

- Base ZRN
- Faible coefficient friction
- Résistant à l'usure
- Recommandé pour aciers non ferreux
- Évite l'adhérence sur les filets de coupe



D mm	L mm	I mm		Nº Art.	€	D mm	L mm	I mm		Nº Art.	€	D mm	L mm	I mm		Nº Art.	€
1,00	34	12	10	59101	1,52	3,75	70	39	10	68365	1,70	6,40	101	63	10	62859	3,12
1,10	36	14	10	62815	1,77	3,80	75	43	10	62839	1,95	6,50	101	63	10	59148	3,02
1,20	38	16	10	62819	1,77	3,90	75	43	10	62841	1,95	6,60	101	63	10	62860	3,74
1,30	38	16	10	62820	1,77	4,00	75	43	10	59131	1,64	6,70	101	63	10	62861	3,74
1,40	40	18	10	62821	1,77	4,10	75	43	10	62842	1,73	6,75	109	69	10	68369	2,82
1,50	40	18	10	59103	1,38	4,20	75	43	10	59133	1,73	6,80	109	69	10	59149	3,51
1,60	43	20	10	62822	1,77	4,25	75	43	10	59134	1,73	6,90	109	69	10	62862	3,74
1,70	43	20	10	62823	1,77	4,30	80	47	10	62843	1,84	7,00	109	69	10	59151	3,29
1,75	46	22	10	68274	1,59	4,40	80	47	10	62844	1,84	7,10	109	69	10	62863	4,76
1,80	46	22	10	62824	1,77	4,50	80	47	10	59137	1,78	7,20	109	69	10	62864	4,76
1,90	46	22	10	62826	1,77	4,60	80	47	10	62845	2,05	7,25	109	69	10	68370	3,90
2,00	49	24	10	59100	1,43	4,70	80	47	10	62846	2,05	7,30	109	69	10	62865	4,76
2,10	49	24	10	62827	1,67	4,75	80	47	10	68350	1,83	7,40	109	69	10	62866	4,76
2,20	53	27	10	62828	1,67	4,80	86	52	10	62847	2,05	7,50	109	69	10	59155	3,51
2,25	53	27	10	68363	1,53	4,90	86	52	10	62848	2,05	7,60	117	75	10	62867	5,75
2,30	53	27	10	62829	1,67	5,00	86	52	10	58831	1,86	7,70	117	75	10	62868	5,75
2,40	57	30	10	62830	1,67	5,10	86	52	10	62849	2,22	7,75	117	75	10	68371	4,44
2,50	57	30	10	59104	1,29	5,20	86	52	10	59139	2,22	7,80	117	75	10	62869	5,75
2,60	57	30	10	62831	1,62	5,25	86	52	10	68366	2,13	7,90	117	75	10	62870	5,75
2,70	61	33	10	62832	1,62	5,30	86	52	10	62850	2,22	8,00	117	75	10	59157	4,11
2,75	61	33	10	68364	1,38	5,40	93	57	10	62851	2,22	8,10	117	75	5	62871	5,49
2,80	61	33	10	62833	1,62	5,50	93	57	10	59140	2,36	8,20	117	75	5	62872	5,49
2,90	61	33	10	62834	1,62	5,60	93	57	10	62852	2,82	8,25	117	75	5	68372	4,13
3,00	61	33	10	59115	1,26	5,70	93	57	10	62853	2,82	8,30	117	75	5	62873	5,49
3,10	65	36	10	62835	1,56	5,75	93	57	10	68367	2,74	8,40	117	75	5	62874	5,49
3,20	65	36	10	59118	1,56	5,80	93	57	10	62854	2,82	8,50	117	75	5	59158	4,29
3,25	65	36	10	59121	1,56	5,90	93	57	10	62855	2,82	8,60	125	81	5	62875	6,97
3,30	65	36	10	59124	1,56	6,00	93	57	10	59145	2,51	8,70	125	81	5	62876	6,97
3,40	70	39	10	62836	1,62	6,10	101	63	10	62856	3,12	8,75	125	81	5	68373	5,33
3,50	70	39	10	59127	1,53	6,20	101	63	10	62857	3,12	8,80	125	81	5	62877	6,97
3,60	70	39	10	62837	1,95	6,25	101	63	10	68368	2,91	8,90	125	81	5	62878	6,97
3,70	70	39	10	62838	1,95	6,30	101	63	10	62858	3,12	9,00	125	81	5	59161	5,47

Ref. **1015**

BROCA MANGO CILÍNDRICO ZIRKONIO

Zirkonio Straight Shank Drill Bit
Foret queue cylindrique Zirkonio



D mm	L mm	I mm	Icon	Nº Art.	€	D mm	L mm	I mm	Icon	Nº Art.	€	D mm	L mm	I mm	Icon	Nº Art.	€
9,10	125	81	5	62879	7,74	10,30	133	87	5	62889	10,46	11,70	142	94	5	62907	14,33
9,20	125	81	5	62880	7,74	10,40	133	87	5	62890	10,46	11,80	142	94	5	62908	14,33
9,25	125	81	5	68374	5,96	10,50	133	87	5	59167	8,82	11,90	151	101	5	62909	14,33
9,30	125	81	5	62881	7,74	10,60	133	87	5	62892	12,16	12,00	151	101	5	59173	12,47
9,40	125	81	5	62882	7,74	10,70	142	94	5	62893	12,16	12,10	151	101	5	62910	16,60
9,50	125	81	5	59163	5,66	10,80	142	94	5	62895	12,16	12,20	151	101	5	62918	16,60
9,60	133	87	5	62883	9,10	10,90	172	94	5	62896	12,16	12,30	151	101	5	62921	16,60
9,70	133	87	5	62884	9,10	11,00	142	94	5	59170	9,75	12,40	151	101	5	62923	16,60
9,75	133	87	5	68375	6,65	11,10	142	94	5	62898	13,83	12,50	151	101	5	59176	15,17
9,80	133	87	5	62886	9,10	11,20	142	94	5	62900	13,83	12,60	151	101	5	62927	17,33
9,90	133	87	5	62887	9,10	11,30	142	94	5	62902	13,83	12,70	151	101	5	62930	17,33
10,00	133	87	5	59164	6,22	11,40	142	94	5	62904	13,83	12,80	151	101	5	62932	17,33
10,10	133	87	5	62888	10,46	11,50	142	94	5	59172	11,65	12,90	151	101	5	62934	17,33
10,20	133	87	5	59166	8,82	11,60	172	94	5	62905	14,33	13,00	151	101	5	59179	15,53

Expo
1015

BROCA MANGO CILÍNDRICO ZIRKONIO

Zirkonio Straight Shank Drill Bit
Foret queue cylindrique Zirkonio

Cuartos / Quarters / Quarts

ø	1	1,5	2	2,5	3	3,25
Pcs	10	10	30	10	50	10
ø	3,5	4	4,25	4,5	5	
Pcs	10	50	10	10	40	
ø	5,5	6	6,5	7		
Pcs	10	50	10	10		
ø	7,5	8	8,5	9		
Pcs	10	20	10	10		
ø	9,5	10	11	12	13	
Pcs	5	10	5	5	5	

Nº Art. 15999: **1.076,58 €**

Previos Roscado / Before Threading / Pré-Tarudage

ø	1	1,5	2	2,5	3	3,3	
Pcs	10	10	30	10	50	10	
ø	3,5	4	4,2	4,5	5		
Pcs	10	50	10	10	40		
ø	5,5	6	6,5	6,8			
Pcs	10	50	10	10			
ø	7	7,5	8	8,5			
Pcs	10	10	20	10			
ø	9	9,5	10	10,2	11	12	13
Pcs	10	5	10	5	5	5	5

Nº Art. 16001: **1.155,75 €**



Línea 1m 1015

BROCA MANGO CILÍNDRICO ZIRKONIO

Zirkonio Straight Shank Drill Bit
Foret queue cylindrique Zirkonio

Cuartos / Quarters / Quarts

1,5 10	3 50	4 50	5 40	6 50	7 10	8 20	9 10	10 10	12 5	mm pcs
	2,5 10	3,5 10	4,5 10							
1 10	2 30	3,25 10	4,25 10	5,5 10	6,5 10	7,5 10	8,5 10	9,5 5	11 5	13 5

Nº Art. 71396: 1.076,58 €

Previos Roscado / Before Threading / Pré-Taraudage

1,5 10	3 50	4 50	5 40	6 50	7 10	8 20	9,5 5	10,2 5	12 5	mm pcs
	2,5 10	3,5 10	4,5 10		6,8 10		9 10			
1 10	2 30	3,3 10	4,2 10	5,5 10	6,5 10	7,5 10	8,5 10	10 10	11 5	13 5

Nº Art. 71638: 1.155,75 €



Cabinet 1015

BROCA MANGO CILÍNDRICO ZIRKONIO

Zirkonio Straight Shank Drill Bit
Foret queue cylindrique Zirkonio



200 Pcs

∅	1	1,5	2	2,5	3	3,5	4	4,5
Pcs	10	10	10	10	10	10	10	10
∅	5	5,5	6	6,5	7			
Pcs	10	10	10	10	10			
∅	7,5	8	8,5	9				
Pcs	10	10	5	5				
∅	9,5	10	10,5	11				
Pcs	5	5	5	5				
∅	11,5	12	12,5	13				
Pcs	5	5	5	5				

Nº Art. 14229: 800,08 €

Ref. **1065**

BROCA MANGO CILÍNDRICO ZIRKONIO

Zirkonio Straight Shank Drill Bit
Foret queue cylindrique Zirkonio

New!



HSS
+
Zirkonio

DIN
338 N



Tol. D
h8

Aceros
<850 N/mm²
Steel / Aciers

Fundición
Cast Iron
Fonte

Aluminio
Aluminium



D mm	L mm	I mm		Nº Art.	€
1,00	34	12	2	14509	3,51 *
1,50	40	18	2	14547	3,15 *
2,00	49	24	2	14592	3,28 *
2,50	57	30	2	14640	2,97 *
3,00	61	33	2	14682	2,91 *
3,25	65	36	2	14694	3,58 *
3,30	65	36	2	14700	3,58 *
3,50	70	39	2	14731	3,53 *
4,00	75	43	2	14734	3,77 *
4,20	75	43	1	14743	1,99
4,25	75	43	1	14749	1,99
4,50	80	47	1	14757	2,04
5,00	86	52	1	14758	2,15
5,50	93	57	1	14772	2,72

D mm	L mm	I mm		Nº Art.	€
6,00	93	57	1	14776	2,88
6,50	101	63	1	14784	3,32
7,00	109	69	1	14787	3,62
7,50	109	69	1	14794	3,86
8,00	117	75	1	14796	4,52
8,50	117	75	1	14799	4,71
9,00	125	81	1	14805	6,02
9,50	125	81	1	14809	6,22
10,00	133	87	1	14811	6,53
10,20	133	87	1	14812	9,26
10,50	133	87	1	14814	9,26
11,00	142	94	1	14818	10,23
11,50	142	94	1	14821	12,23
12,00	151	101	1	14823	13,09
13,00	151	101	1	14824	16,31

* € = 2 uds.



Sets 1015

BROCA MANGO CILÍNDRICO ZIRKONIO

Zirkonio Straight Shank Drill Bit
Foret queue cylindrique Zirkonio

Set **1462**



6 Pcs

Cont. Ø	Nº Art.	€
2 - 3 - 4 - 5 - 6 - 8 mm	59236	13,63

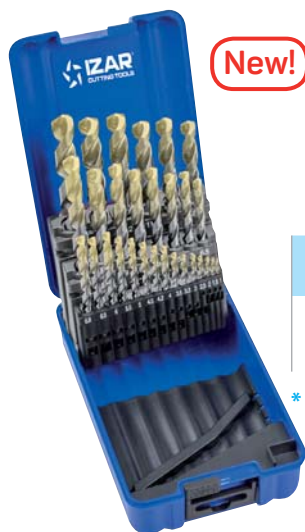

New!

Set **1459**

29 Pcs

Cont. Ø	Nº Art.	€
1 - 13 x 0,5 mm *	15115	145,84

* + Previos Roscado / Before Threading
Pré-Tarudage (3,3 - 4,2 - 6,8 - 10,2 mm)



Set **1406**

91 Pcs

Cont. Ø	Nº Art.	€
1-10 x 0,10 mm	66483	343,49

* Base roja / Red base / Base rouge

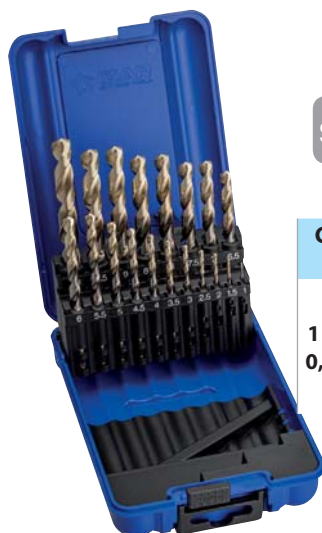

Set **1466**

19 Pcs

Cont. Ø	Nº Art.	€
1 - 10 x 0,5 mm	59234	56,38

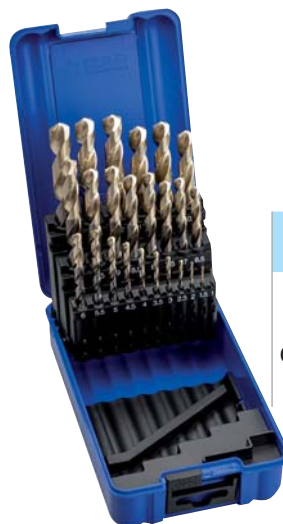

Set **1456**

25 Pcs

Cont. Ø	Nº Art.	€
1 - 13 x 0,5 mm	59235	130,50



Box-Pallet
1015

5 Sets 1466

Nº Art.	Cont. Set	€
80662	1 - 10 x 0,5 mm	267,82



Box-Pallet
1015

5 Sets 1456

Nº Art.	Cont. Set	€
80678	1 - 13 x 0,5 mm	619,86

Ref. **1010**

BROCA MANGO CILÍNDRICO HSS

HSS Straight Shank Drill Bit
Foret queue cylindrique HSS



CLASSIQUE



HSS
+
TIN

DIN
338 N



Usos General
General Purpose
Utilisation générale

Aceros
<850 N/mm²
Steel / Aciers

Fundición
Cast Iron
Fonte

Aluminio
Aluminium



D mm	L mm	I mm		Nº Art. HSS	€	Nº Art. TIN	€	D mm	L mm	I mm		Nº Art. HSS	€	Nº Art. TIN	€
0,30	19	3	10	17996	1,85			2,20	53	27	10	10043	0,71	18338	1,61
0,35	19	4	10	17999	1,91			2,25	53	27	10	10046	0,66	18341	1,57
0,40	20	5	10	18002	1,85			2,30	53	27	10	10049	0,83	18344	1,73
0,45	20	5	10	18005	1,85			2,35	53	27	10	18080	0,83		
0,50	22	6	10	18008	1,30			2,40	57	30	10	10052	0,83	18347	1,73
0,55	24	7	10	18011	1,64			2,45	57	30	10	18083	0,83		
0,60	24	7	10	18014	1,64			2,50	57	30	10	10055	0,69	18350	1,62
0,65	26	8	10	18017	1,64			2,55	57	30	10	18086	0,85		
0,70	28	9	10	18020	1,64			2,60	57	30	10	10058	0,85	18353	1,74
0,75	28	9	10	18023	1,20			2,65	57	30	10	18089	0,85		
0,80	30	10	10	18026	1,23			2,70	61	33	10	10061	0,85	27166	1,74
0,85	30	10	10	18029	1,23			2,75	61	33	10	10064	0,73	18356	1,68
0,90	32	11	10	18032	1,23			2,80	61	33	10	10067	0,85	18359	1,74
0,95	32	11	10	18035	1,23			2,85	61	33	10	18092	0,85		
1,00	34	12	10	10001	0,95	18305	1,96	2,90	61	33	10	10070	0,85	27088	1,74
1,05	34	12	10	18038	1,06			2,95	61	33	10	18095	0,85		
1,10	36	14	10	10004	1,06	15056	1,98	3,00	61	33	10	10073	0,62	18362	1,52
1,15	36	14	10	18041	1,06			3,05	65	36	10	18098	0,82	17358	1,97
1,20	38	16	10	10007	1,06	18308	1,98	3,10	65	36	10	10076	0,73	18365	1,93
1,25	38	16	10	10010	0,84	27087	1,84	3,15	65	36	10	27343	0,82	29078	1,97
1,30	38	16	10	10013	0,93	18311	1,91	3,20	65	36	10	10079	0,73	18368	1,93
1,35	40	18	10	18050	0,93			3,25	65	36	10	10082	0,73	18371	1,93
1,40	40	18	10	10016	0,93	27337	1,91	3,30	65	36	10	10085	0,73	18374	1,93
1,45	40	18	10	18053	0,93			3,35	65	36	10	27345	0,93		
1,50	40	18	10	10019	0,73	18314	1,68	3,40	70	39	10	10088	0,94	27322	2,07
1,55	43	20	10	18059	0,90			3,45	70	39	10	27346	0,94	21777	2,07
1,60	43	20	10	10022	0,90	18317	1,88	3,50	70	39	10	10091	0,71	18377	1,90
1,65	43	20	10	18062	0,90			3,55	70	39	10	18101	0,97		
1,70	43	20	10	10025	0,90	18320	1,88	3,60	70	39	10	10094	0,97	27323	2,09
1,75	46	22	10	10028	0,80	18323	1,83	3,65	70	39	10	18104	0,97		
1,80	46	22	10	10031	0,80	18326	1,79	3,70	70	39	10	10097	0,97	18380	2,09
1,85	46	22	10	18068	0,80			3,75	70	39	10	10100	0,83	18383	2,02
1,90	46	22	10	10034	0,80	18329	1,79	3,80	75	43	10	10103	1,00	18386	2,12
1,95	49	24	10	18071	0,80			3,85	75	43	10	18107	1,00	79546	2,12
2,00	49	24	10	10037	0,69	18332	1,68	3,90	75	43	10	10106	1,00	27165	2,12
2,05	49	24	10	18074	0,71			3,95	75	43	10	18110	1,00		
2,10	49	24	10	10040	0,71	18335	1,61	4,00	75	43	10	10109	0,81	18389	1,99
2,15	53	27	10	18077	0,71			4,05	75	43	10	27349	1,00		

Expo
1010

BROCA MANGO CILÍNDRICO HSS

HSS Straight Shank Drill Bit
Foret queue cylindrique HSS



Cuartos / Quarters / Quarts

∅	1	1,5	2	2,5	3	3,25
Pcs	30	20	40	30	80	20
∅	3,5	4	4,25	4,5	5	
Pcs	20	60	10	20	80	
∅	5,5	6	6,5	7		
Pcs	10	60	20	20		
∅	7,5	8	8,5	9		
Pcs	10	40	10	10		
∅	9,5	10	11	12	13	
Pcs	10	30	15	20	10	

Nº Art. 57523: **1.070,74 €**

Previos Roscado / Before Threading / Pré-Tarudage

∅	1	1,5	2	2,5	3	3,3
Pcs	30	20	40	30	80	20
∅	3,5	4	4,2	4,5	5	
Pcs	20	60	10	20	80	
∅	5,5	6	6,5	6,8		
Pcs	10	60	20	10		
∅	7	7,5	8	8,5		
Pcs	20	10	40	10		
∅	9	9,5	10	10,2	11	12
Pcs	10	10	30	10	15	20
						13
						10

Nº Art. 57975: **1.134,46 €**

Línea 1m
1010

BROCA MANGO CILÍNDRICO HSS

HSS Straight Shank Drill Bit
Foret queue cylindrique HSS



Cuartos / Quarters / Quarts

1,5	3	4	5	6	7	8	9	10	12	mm pcs
	80	60	80							
20	2,5	3,5	4,5	5,5	6,5	7,5	8,5	9,5	11	13
	30	20	20							
1	2	3,25	4,25	5,5	6,5	7,5	8,5	9,5	11	13
	30	40	20							

Nº Art. 70965: **1.070,74 €**

Previos Roscado / Before Threading / Pré-Tarudage

1,5	3	4	5	6	7	8	9,5	10,2	12	mm pcs
	80	60	80				60			
20	2,5	3,5	4,5	5,5	6,8	7,5	9	10	11	13
	30	20	20				10			
1	2	3,3	4,2	5,5	6,5	7,5	8,5	10	11	13
	30	40	20				10			

Nº Art. 70999: **1.134,46 €**

Cabinet 1010

BROCA MANGO CILÍNDRICO HSS

HSS Straight Shank Drill Bit
Foret queue cylindrique HSS



400 Pcs

∅	1	1,5	2	2,5	3	3,5	4	4,5
Pcs	10	10	20	20	50	30	40	20
∅	5	5,5	6	6,5	7			
Pcs	40	10	30	10	10			
∅	7,5	8	8,5	9				
Pcs	10	20	10	10				
∅	9,5	10	10,5	11				
Pcs	10	10	5	5				
∅	11,5	12	12,5	13				
Pcs	5	5	5	5				

Nº Art. 55440: **656,68 €**

Ref. **1001**

BROCA MANGO CILÍNDRICO HSS

HSS Straight Shank Drill Bit
Foret queue cylindrique HSS



CLASSIQUE



HSS
+
TIN

DIN
338 N



Usos General
General Purpose
Utilisation générale

Aceros
<850 N/mm²
Steel / Aciers

Fundición
Cast Iron
Fonte

Aluminio
Aluminium



D mm	L mm	I mm		Nº Art. HSS	€	Nº Art. TIN	€
1,00	34	12	2	18781	2,26	16527	4,64 *
1,50	40	18	2	18783	1,70	16528	3,99 *
2,00	49	24	2	18792	1,63	16529	3,99 *
2,50	57	30	2	18793	1,63	16530	3,84 *
3,00	61	33	2	18687	1,47	16531	3,63 *
3,25	65	36	2	30156	1,68	16532	4,48 *
3,30	65	36	2	34039	1,68		*
3,50	70	39	2	18688	1,64	16533	4,41 *
4,00	75	43	2	18589	1,86	16534	4,60 *
4,20	75	43	1	34040	1,05		
4,25	75	43	1	30157	1,05	16535	2,38
4,50	80	47	1	18591	1,06	16536	2,41
5,00	86	52	1	18592	1,13	16537	2,48
5,50	93	57	1	18594	1,52	16538	2,84
6,00	93	57	1	18595	1,57	16539	2,89
6,50	101	63	1	18597	1,77	16540	5,28
6,80	109	69	1	34041	2,16		
7,00	109	69	1	18645	2,16	16541	5,64
7,50	109	69	1	18646	2,24	16542	5,75
8,00	117	75	1	18655	2,58	16543	6,06
8,50	117	75	1	18657	2,78	16544	6,86
9,00	125	81	1	18666	3,39	16545	7,42
9,50	125	81	1	66989	3,59		
10,00	133	87	1	18667	3,84	16546	7,77
10,20	133	87	1	34042	4,82		
10,50	133	87	1	66991	4,82		
11,00	142	94	1	30158	5,60	16547	13,62
11,50	142	94	1	66993	6,01		
12,00	151	101	1	18676	6,67	16549	14,66
12,50	151	101	1	66995	7,34		
13,00	151	101	1	30159	7,58	16550	17,62

* € = 2 uds.



Línea 1m
1001

BROCA MANGO CILÍNDRICO HSS

HSS Straight Shank Drill Bit
Foret queue cylindrique HSS



∅	1	1,5	2	2,5	3	3,25	3,5	4	4,25	4,5	5	5,5	6	6,5	7	7,5	8	9	10	
Pcs	10	10	10	10	10	10	10	10	10	10	10	10	10	10	10	10	10	10	10	10

Ref. 4995 - Nº Art. 70942: 361,86 €

Display
14

BROCA MANGO CILÍNDRICO HSS

HSS Straight Shank Drill Bit
Foret queue cylindrique HSS



∅	7,5	8	8,5	9	10	11	12	13		
Pcs	5	5	5	5	3	3	3	3		
∅	4	4,25	4,5	5	5	5,5	6	6	6,5	7
Pcs	10	10	10	10	10	5	5	5	5	5
∅	1	1,5	2	2,5	3	3	3,25	3,5	3,5	4
Pcs	10	10	10	10	10	10	10	10	10	10

Ref. 4995 - Nº Art. 22162: 401,11 €

Display
46

BROCA MANGO CILÍNDRICO HSS + PREVIOS ROSCADO

HSS Straight Shank Drill Bit + Before Threading
Foret queue cylindrique HSS + Pré-Taraudage



∅	8	8,5	9	10	10,2	11	12	13		
Pcs	5	5	5	3	3	3	3	3		
∅	4,25	4,5	5	5	5,5	6	6,5	6,8	7	7,5
Pcs	15	8	8	7	5	10	5	5	5	5
∅	1	1,5	2	2,5	3	3,25	3,3	3,5	4	4,2
Pcs	10	10	10	10	10	10	8	10	10	8

Ref. 4995 - Nº Art. 55618: 395,92 €

Display 51



BROCAS METAL + PARED + MADERA

Metal + Masonry + Wood Drill Bits
Forets Métal + Maçonnerie + Bois

Ref. 1880	∅	3	4	5	6	7	8	9	10	12	14
	Pcs	10	10	10	10	10	10	5	5	5	5
Ref. 1640	∅	3	4	5	6	8	9	10	12	14	16
	Pcs	10	10	10	10	10	5	5	5	5	5
Ref. 1001	∅	1	2	3	3,5	4	4,5	5	6	8	10
	Pcs	10	10	10	10	10	10	10	5	5	3

Ref. 4995 - N° Art. 68572: 333,01 €

Sets 1010

BROCA MANGO CILÍNDRICO HSS

HSS Straight Shank Drill Bit
Foret queue cylindrique HSS



Set **1462**
6 Pcs

Cont. ∅	N° Art.	€
2 - 3 - 4 - 5 - 6 - 8 mm	30230	7,60



Set **1459**
29 Pcs

Cont. ∅	N° Art.	€
1 - 13 x 0,5 mm *	15070	76,02

* + Previos Roscado / Before Threading
Pré-Taraudage (3,3 - 4,2 - 6,8 - 10,2 mm)



Set **1466**
19 Pcs

Cont. ∅	N° Art.	€
1 - 10 x 0,5 mm	25271	32,33



Set **1456**
25 Pcs

Cont. ∅	N° Art.	€
1 - 13 x 0,5 mm	25235	68,29



**Box-Pallet
1010**
5 Sets 1466

Nº Art.	Cont. Set	€
79644	1 - 10 x 0,5 mm	153,55



**Box-Pallet
1010**
5 Sets 1456

Nº Art.	Cont. Set	€
80671	1 - 13 x 0,5 mm	324,36

**Línea 33 cm
14S1**

SETS BROCAS METAL, PARED PRO, PARED, MADERA

Metal, Concrete, Masonry, Wood Sets
Jeux Métal, Béton, Maçonnerie, Bois



23 cm

	Metal Metal Métal	Pared Pro Concrete Béton	Pared Masonry Maçonnerie	Madera Wood Bois
Ref.	1462-1010	1486	1485	1435
Diam.	2-3-4-5-6-8 mm	4-5-6-8-10 mm	4-5-6-8-10 mm	4-5-6-8-10 mm
Pcs.	5	5	5	5

Ref. 4995 - Nº Art. 72193: 170,80 €

**Display
24**

SETS BROCAS MANGO CILINDRICO HSS + HSSE

HSS + HSSE Straight Shank Drill Bit Sets
Jeux forets queue cylindrique HSS + HSSE



HSSE	Pcs	Ref. 1462 - 1016 Metal Pro 5 Pcs. 5	Ref. 1466 - 1016 Metal Pro 19 Pcs. 1	Ref. 1456 - 1016 Metal Pro 25 Pcs. 1
	Pcs	Ref. 1462 - 1010 Metal 5 Pcs. 5	Ref. 1466 - 1010 Metal 19 Pcs. 2	Ref. 1456 - 1010 Metal 25 Pcs. 2

Ref. 4995 - Nº Art. 22320: 487,46 €

Sets 1010

BROCA MANGO CILÍNDRICO HSS

HSS Straight Shank Drill Bit
Foret queue cylindrique HSS

Set **1407**



37 Pcs

Cont. Ø	Nº Art.	€
1 - 10 x 0,25 mm	26768	89,54

Set **1409**



49 Pcs

Cont. Ø	Nº Art.	€
1 - 13 x 0,25 mm	26802	164,54

Set **1405**



50 Pcs

Cont. Ø	Nº Art.	€
1 - 5,9 x 0,1 mm	26765	61,20

Set **1408**



41 Pcs

Cont. Ø	Nº Art.	€
6 - 10 x 0,1 mm	26771	157,80

Set **1406**

91 Pcs

Cont. Ø	Nº Art.	€
1-10 x 0,10 mm	56685	217,91



* Base roja / Red base / Base rouge

Set **1470**



170 Pcs

220 Pcs

Cont. Ø	Nº Art.	€
1-10 x 0,5 mm Ø 1-8: 10 pcs/Ø Ø 8,5-10: 5 pcs/Ø	19590	249,69
1-13 x 0,5 + 3,3 + 4,2 mm Ø 1-8: 10 pcs/Ø Ø 8,5-13: 5 pcs/Ø	56676	475,37

Sets 1010

BROCA MANGO CILÍNDRICO HSS+TIN

HSS+TIN Straight Shank Drill Bit
Foret queue cylindrique HSS+TIN

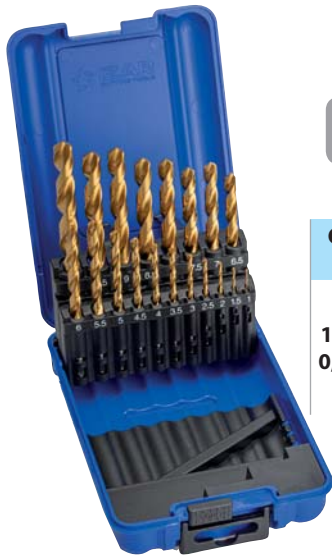

Set **1466**

19 Pcs

Cont. Ø	Nº Art. TIN	€
1 - 10 x 0,5 mm	27132	71,16



Set **1456**

25 Pcs

Cont. Ø	Nº Art. TIN	€
1 - 13 x 0,5 mm	27133	155,24

Set **1407**



37 Pcs

Cont. Ø	Nº Art. TIN	€
1 - 10 x 0,25 mm	27134	166,60

Set **1409**



49 Pcs

Cont. Ø	Nº Art. TIN	€
1 - 13 x 0,25 mm	27135	338,03

Set **1405**



50 Pcs

Cont. Ø	Nº Art. TIN	€
1 - 5,9 x 0,1 mm	13154	113,59

Set **1408**



41 Pcs

Cont. Ø	Nº Art. TIN	€
6 - 10 x 0,1 mm	13152	289,97

Ref. **1013**

BROCA MANGO CILÍNDRICO HSS SPEED POINT

Speed Point HSS Straight Shank Drill Bit
Foret queue cylindrique HSS Speed Point



SPEED POINT



Aceros
<850 N/mm²
Steel / Aciers

Fundición
Cast Iron
Fonte

Aluminio
Aluminium

+ 35 %

TIALSIN

Resistencia al desgaste
Wear Resistance
Haute résistance à l'usure

D mm	L mm	I mm		Nº Art. HSS	€	Nº Art. TIALSIN	€
1,00	34	12	10	17673	1,08	37620	2,55
1,10	36	14	10	10650	1,19		
1,20	38	16	10	10656	1,19		
1,30	38	16	10	10662	1,05		
1,40	40	18	10	10663	1,05		
1,50	40	18	10	10666	0,80	37621	2,29
1,60	43	20	10	10669	0,99		
1,70	43	20	10	10670	0,99		
1,75	46	22	10	10671	0,90		
1,80	46	22	10	10672	0,89		
1,90	46	22	10	10674	0,89		
2,00	49	24	10	10675	0,75	37497	2,22
2,10	49	24	10	10677	0,80		
2,20	53	27	10	13596	0,80		
2,25	53	27	10	10679	0,73		
2,30	53	27	10	13608	0,94		
2,40	57	30	10	10683	0,94		
2,50	57	30	10	10684	0,77	37622	2,12
2,60	57	30	10	10685	0,95		
2,70	61	33	10	10686	0,95		
2,75	61	33	10	10687	0,81		
2,80	61	33	10	10690	0,95		
2,90	61	33	10	10692	0,95		
3,00	61	33	10	10693	0,69	37623	2,02
3,10	65	36	10	10695	0,81		
3,20	65	36	10	10696	0,81	32571	2,59
3,25	65	36	10	10698	0,81		
3,30	65	36	10	10699	0,81	37624	2,59
3,40	70	39	10	10701	1,04		
3,50	70	39	10	10702	0,80	37625	2,58
3,60	70	39	10	10704	1,08		
3,70	70	39	10	10705	1,08		
3,75	70	39	10	10708	0,94		
3,80	75	43	10	10710	1,14	39236	2,92
3,90	75	43	10	10719	1,14		
4,00	75	43	10	10770	0,90	32572	2,69
4,10	75	43	10	10774	1,00		
4,20	75	43	10	10776	1,00	36557	2,77

(New!)

D mm	L mm	I mm		Nº Art. HSS	€	Nº Art. TIALSIN	€
4,25	75	43	10	10777	1,00		
4,30	80	47	10	10779	1,34		
4,40	80	47	10	10780	1,34		
4,50	80	47	10	10782	1,03	37627	2,82
4,60	80	47	10	10783	1,37		
4,70	80	47	10	10786	1,37	69082	3,15
4,75	80	47	10	10787	1,21		
4,80	86	52	10	10789	1,49	39240	3,27
4,90	86	52	10	10792	1,46		
5,00	86	52	10	10793	1,12	17442	2,90
5,10	86	52	10	10795	1,50		
5,20	86	52	10	10797	1,50	39242	3,30
5,25	86	52	10	10798	1,44		
5,30	86	52	10	10799	1,88	45421	3,68
5,40	93	57	10	10800	1,88		
5,50	93	57	10	10801	1,48	37628	3,26
5,60	93	57	10	10802	1,97		
5,70	93	57	10	10804	1,97	39244	3,77
5,75	93	57	10	10807	1,93		
5,80	93	57	10	10808	1,88		
5,90	93	57	10	10810	1,88		
6,00	93	57	10	10811	1,51	32677	3,32
6,10	101	63	10	10813	2,17		
6,20	101	63	10	10814	2,17		
6,25	101	63	10	10815	2,03		
6,30	101	63	10	10816	2,29		
6,40	101	63	10	10819	2,32		
6,50	101	63	10	10822	1,78	36558	6,74
6,60	101	63	10	11145	2,86		
6,70	101	63	10	11154	2,86	45424	7,81
6,75	109	69	10	11157	2,16	66924	7,11
6,80	109	69	10	11163	2,16	37629	7,11
6,90	109	69	10	11166	3,13	45725	8,08
7,00	109	69	10	11172	2,16	36559	7,11
7,10	109	69	10	11175	3,33		
7,20	109	69	10	13066	3,33		
7,25	109	69	10	11184	2,73		
7,30	109	69	10	11190	3,33		

Ref.

1013**BROCA MANGO CILÍNDRICO HSS SPEED POINT**

Speed Point HSS Straight Shank Drill Bit

Foret queue cylindrique HSS Speed Point



D mm	L mm	I mm		Nº Art. HSS	€	Nº Art. TIALSIN	€		D mm	L mm	I mm		Nº Art. HSS	€	Nº Art. TIALSIN	€	
7,40	109	69	10	11202	3,33				(New!) 10,75	142	94	5	53633	6,34			
7,50	109	69	10	11217	2,26	37630	7,22		10,80	142	94	5	17972	7,63			
7,60	117	75	10	14362	3,94				10,90	142	94	5	17975	7,63			
7,70	117	75	10	11226	3,94				11,00	142	94	5	13783	5,83	37635	16,97	
7,75	117	75	10	11229	3,04				11,10	142	94	5	17978	7,78			
7,80	117	75	10	11230	3,97				11,20	142	94	5	66583	7,78			
7,90	117	75	10	11251	3,97				(New!) 11,25	142	94	5	53636	6,48			
8,00	117	75	10	11268	2,59	36560	7,55		11,30	142	94	5	17980	7,78			
8,10	117	75	5	11269	4,05				11,40	142	94	5	17981	7,78			
8,20	117	75	5	11287	4,05	64063	9,79		11,50	142	94	5	17609	6,23	37636	17,39	
8,25	117	75	5	11290	3,04				11,60	142	94	5	17982	7,64			
8,30	117	75	5	11297	4,24				11,70	142	94	5	19657	7,64			
8,40	117	75	5	11302	4,24				11,80	142	94	5	17984	8,35			
8,50	117	75	5	11303	2,80	37498	8,53		11,90	151	101	5	17987	8,35			
8,60	125	81	5	11304	5,32				12,00	151	101	5	17611	6,93	37637	18,11	
8,70	125	81	5	11305	5,32				12,10	151	101	5	63357	9,75			
8,75	125	81	5	11306	4,08				12,20	151	101	5	63358	9,75			
8,80	125	81	5	11307	5,34				(New!) 12,25	151	101	5	53639	8,43			
8,90	125	81	5	11308	5,34				12,30	151	101	5	22343	9,17			
9,00	125	81	5	11310	3,42	37631	9,15		12,40	151	101	5	63360	9,17			
9,10	125	81	5	14378	5,37	39252	11,12		12,50	151	101	5	17615	7,60	37638	21,67	
9,20	125	81	5	14304	5,37	64064	11,11		12,60	151	101	5	63361	9,55			
9,25	125	81	5	11313	4,13				12,70	151	101	5	17081	9,55			
9,30	125	81	5	14305	4,99				(New!) 12,75	151	101	5	53645	8,31			
9,40	125	81	5	13007	4,99				12,80	151	101	5	63363	10,61			
9,50	125	81	5	11317	3,71	37632	9,45		12,90	151	101	5	63364	10,61			
9,60	133	87	5	11318	6,41				13,00	151	101	5	16556	7,88	36556	21,96	
9,70	133	87	5	13440	6,41				13,50	160	108	1	22833	11,17	83459	25,19	
9,75	133	87	5	11321	4,67				14,00	160	108	1	19224	11,98	64065	26,00	
9,80	133	87	5	11322	6,31				14,50	169	114	1	24941	12,88			
9,90	133	87	5	11323	6,31				(New!) 15,00	169	114	1	19227	13,04	12770	26,69	
10,00	133	87	5	11324	3,99	36147	9,74		15,50	178	120	1	51929	14,97			
10,10	133	87	5	22341	5,37				(New!) 16,00	178	120	1	22306	15,89	12771	26,96	
10,20	133	87	5	17648	4,98	37633	16,15		16,50	184	125	1	51640	17,58			
(New!) 10,25	133	87	5	53630	5,48				(New!) 17,00	184	125	1	48580	17,58	12784	30,20	
10,30	133	87	5	17506	6,26	37634	17,44		17,50	191	130	1	48582	20,21			
10,40	133	87	5	17966	6,26				(New!) 18,00	191	130	1	48583	21,39	12792	34,02	
10,50	133	87	5	17613	4,98	38088	16,15		18,50	198	135	1	48585	23,75			
10,60	133	87	5	17969	6,87				(New!) 19,00	198	135	1	48586	23,75	12793	36,38	
10,70	142	94	5	22342	6,87				19,50	205	140	1	48588	25,45			
									(New!) 20,00	205	140	1	48589	29,01	12794	41,64	



Expo
1013

BROCA MANGO CILÍNDRICO HSS SPEED POINT

Speed Point HSS Straight Shank Drill Bit
Foret queue cylindrique HSS Speed Point



Cuartos / Quarters / Quarts

∅	1	1,5	2	2,5	3	3,25
Pcs	30	20	40	30	50	30
∅	3,5	4	4,25	4,5	5	
Pcs	30	50	30	30	50	
∅	5,5	6	6,5	7		
Pcs	40	50	20	20		
∅	7,5	8	8,5	9		
Pcs	20	40	20	20		
∅	9,5	10	11	12	13	
Pcs	5	20	5	10	5	

Nº Art. 57524: **1.069,40 €**

Previos Roscado / Before Threading / Pré-Taradage

∅	1	1,5	2	2,5	3	3,3
Pcs	30	20	40	30	50	30
∅	3,5	4	4,2	4,5	5	
Pcs	30	50	30	30	50	
∅	5,5	6	6,5	6,8		
Pcs	40	50	20	10		
∅	7	7,5	8	8,5		
Pcs	20	20	40	20		
∅	9	9,5	10	10,2	11	12
Pcs	20	5	20	5	5	10
						13
						5

Nº Art. 57976: **1.115,84 €**

Línea 1m
1013

BROCA MANGO CILÍNDRICO HSS SPEED POINT

Speed Point HSS Straight Shank Drill Bit
Foret queue cylindrique HSS Speed Point

Cuartos / Quarters / Quarts

1,5 20	3	4	5	6 50	7 20	8 40	9 20	10 20	12 10	mm pcs
	2,5	3,5	4,5							
1 30	2	3,25	4,25	5,5 40	6,5 20	7,5 20	8,5 20	9,5 5	11 5	13 5
	3	4	5							

Nº Art. 71057: **1.069,40 €**

Previos Roscado / Before Threading / Pré-Taradage

1,5 30	3	4	5	6 50	7 20	8 40	9,5 5	10,2 5	12 10	mm pcs
	2,5	3,5	4,5							
1 20	2	3,3	4,2	5,5 40	6,8 10	7,5 20	9 20	10 20	11 5	13 5
	3	4	5							

Nº Art. 71390: **1.115,84 €**



Cabinet 1013

BROCA MANGO CILÍNDRICO HSS SPEED POINT

Speed Point HSS Straight Shank Drill Bit
Foret queue cylindrique HSS Speed Point



350 Pcs

∅	1	1,5	2	2,5	3	3,5	4	4,5				
Pcs	10	10	20	20	40	20	40	20				
∅	5		5,5		6		6,5		7			
Pcs	30		10		30		10		10			
∅	7,5			8			8,5			9		
Pcs	10			20			5			5		
∅	9,5			10			10,5			11		
Pcs	5			5			5			5		
∅	11,5			12			12,5			13		
Pcs	5			5			5			5		

Nº Art. 55443: **623,91 €**

Ref. **1002**

BROCA MANGO CILÍNDRICO HSS SPEED POINT

Speed Point HSS Straight Shank Drill Bit
Foret queue cylindrique HSS Speed Point



SPEED POINT



Aceros
<850 N/mm²
Steel / Aciers

Fundición
Cast Iron
Fonte

Aluminio
Aluminium



D mm	L mm	I mm		Nº Art.	€
1,00	34	12	2	24778	2,49 *
1,50	40	18	2	16516	1,86 *
2,00	49	24	2	24779	1,77 *
2,50	57	30	2	24780	1,81 *
3,00	61	33	2	24781	1,61 *
3,25	65	36	2	24782	1,84 *
3,30	65	36	2	39913	1,84 *
3,50	70	39	2	24783	1,81 *
3,80	75	43	2	79610	2,58 *
4,00	75	43	2	24784	2,04 *
4,20	75	43	1	39914	1,13
4,25	75	43	1	24785	1,13
4,50	80	47	1	24786	1,17
4,80	86	52	1	79611	1,69
5,00	86	52	1	24787	1,26
5,20	86	52	1	73529	1,71
5,50	93	57	1	24788	1,68
5,80	93	57	1	79612	2,13
6,00	93	57	1	24789	1,73
6,50	101	63	1	24790	1,94
6,80	109	69	1	39915	2,36
7,00	109	69	1	24791	2,36
7,50	109	69	1	24792	2,48
8,00	117	75	1	24793	2,83
8,50	117	75	1	24794	3,06
9,00	125	81	1	24795	3,74
9,50	125	81	1	74946	4,06
10,00	133	87	1	24796	4,24
10,20	133	87	1	39916	5,29
10,50	133	87	1	74949	5,29
11,00	142	94	1	24797	6,16
11,50	142	94	1	74950	6,61
12,00	151	101	1	24798	7,34
12,50	151	101	1	79613	8,06
13,00	151	101	1	24799	8,37
14,00	160	108	1	79614	12,71



Doble Blister
ref. M013
pag. 372

* € = 2 uds.



Línea 1m
1002

BROCA MANGO CILÍNDRICO HSS SPEED POINT

Speed Point HSS Straight Shank Drill Bit
Foret queue cylindrique HSS Speed Point



∅	1	1,5	2	2,5	3	3,25	3,5	4	4,25	4,5	5	5,5	6	6,5	7	7,5	8	9	10	
Pcs	10	10	10	10	10	10	10	10	10	10	10	10	10	10	10	10	10	10	10	10

Ref. 4995 - N° Art. 70947: 397,96 €

Display
17

BROCA MANGO CILÍNDRICO HSS SPEED POINT

Speed Point HSS Straight Shank Drill Bit
Foret queue cylindrique HSS Speed Point



∅	7,5	8	8,5	9	10	11	12	13		
Pcs	8	8	5	5	3	3	3	3		
∅	4	4,25	4,5	5	5	5,5	6	6	6,5	7
Pcs	5	10	10	5	5	10	5	5	10	8
∅	1	1,5	2	2,5	3	3	3,25	3,5	3,5	4
Pcs	10	10	10	10	5	5	10	5	5	5

Ref. 4995 - N° Art. 22492: 415,14 €

Display 47



BROCA M. CILÍNDRICO HSS SPEED POINT + PREVIOS ROSCADO

Speed Point HSS Straight Shank Drill Bit + Before Threading

Foret queue cylindrique HSS Speed Point + Pré-Taroudage

∅	8	8,5	9	10	10,2	11	12	13		
Pcs	5	5	5	3	3	3	3	3		
∅	4,25	4,5	5	5	5,5	6	6,5	6,8	7	7,5
Pcs	10	5	5	5	5	10	5	5	5	5
∅	1	1,5	2	2,5	3	3,25	3,3	3,5	4	4,2
Pcs	10	10	10	5	10	10	5	10	10	5

Ref. 4995 - N° Art. 55620: **401,63 €**

Display 59



BROCAS SPEED POINT + PARED + MADERA

Speed Point + Masonry + Wood Drill Bits

Forets Speed Point + Maçonnerie + Bois

Ref. 1880	∅	3	4	5	6	7	8	9	10	12	14
	Pcs	10	10	10	10	10	10	5	5	5	5
Ref. 1640	∅	3	4	5	6	8	9	10	12	14	16
	Pcs	10	10	10	10	10	5	5	5	5	5
Ref. 1002	∅	2	3	3,5	4	4,5	5	6	7	8	10
	Pcs	10	10	10	10	10	10	5	5	5	3

Ref. 4995 - N° Art. 70099: **334,26 €**

Sets 1013

BROCA MANGO CILÍNDRICO HSS SPEED POINT

Speed Point HSS Straight Shank Drill Bit
Foret queue cylindrique HSS Speed Point



Set **1462**

6 Pcs

Cont. Ø	Nº Art.	€
2 - 3 - 4 - 5 - 6 - 8 mm	25365	8,38



Set **1459**

29 Pcs

Cont. Ø	Nº Art.	€
1 - 13 x 0,5 mm *	15088	84,75

* + Previos Roscado / Before Threading
Pré-Taroudage (3,3 - 4,2 - 6,8 - 10,2 mm)

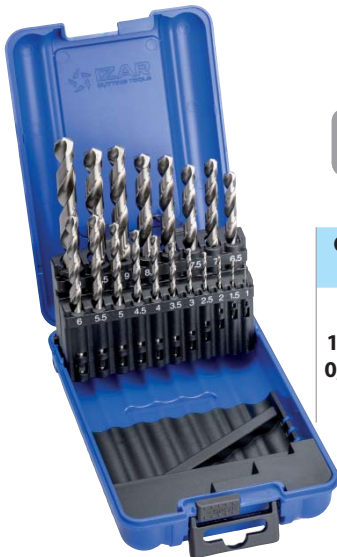

Set **1466**

19 Pcs

Cont. Ø	Nº Art.	€
1 - 10 x 0,5 mm	18808	35,90



Set **1456**

25 Pcs

Cont. Ø	Nº Art.	€
1 - 13 x 0,5 mm	18807	76,08



Box-Pallet
1013

5 Sets 1466

Nº Art.	Cont. Set	€
80659	1 - 10 x 0,5 mm	170,53



Box-Pallet
1013

5 Sets 1456

Nº Art.	Cont. Set	€
80675	1 - 13 x 0,5 mm	361,37

Sets 1013

BROCA MANGO CILÍNDRICO HSS SPEED POINT

Speed Point HSS Straight Shank Drill Bit
Foret queue cylindrique HSS Speed Point



TIALSIN Set **1466**
19 Pcs

Cont. Ø	Nº Art. TIALSIN	€
1 - 10 x 0,5 mm	38833	96,50

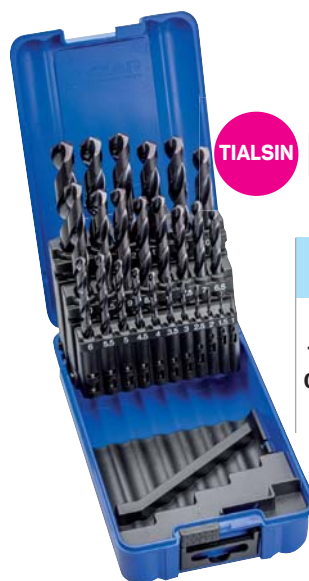

TIALSIN Set **1456**
25 Pcs

Cont. Ø	Nº Art. TIALSIN	€
1 - 13 x 0,5 mm	38832	209,48

Set **1406**



* Base roja / Red base / Base rouge

91 Pcs

Cont. Ø	Nº Art.	€
1-10 x 0,10 mm	60624	241,17

Set **1470**



170 Pcs

220 Pcs

Cont. Ø	Nº Art.	€
1-10 x 0,5 mm Ø 1-8: 10 pcs/Ø Ø 8,5-10: 5 pcs/Ø	56677	278,00
1-13 x 0,5 + 3,3 + 4,2 mm Ø 1-8: 10 pcs/Ø Ø 8,5-13: 5 pcs/Ø	56679	526,58

Ref. **1007**

BROCA MANGO REBAJADO HSS

HSS Reduced Shank Drill Bit
Foret queue reduite HSS



Aceros
<850 N/mm²
Steel / Aciers

Fundición
Cast Iron
Fonte

Aluminio
Aluminium

D	d	L	l	∅	Nº	€	D	d	L	l	∅	Nº	€	D	d	L	l	∅	Nº	€
mm	mm	mm	mm	mm	Art.		mm	mm	mm	mm	mm	Art.		mm	mm	mm	mm	mm	Art.	
10,50	10,00	133	87	1	15976	6,62	15,50	12,70	178	120	1	15988	17,21	20,50	12,70	205	145	1	66932	35,13
11,00	10,00	142	94	1	15977	7,49	16,00	12,70	178	120	1	15989	17,84	21,00	12,70	205	145	1	17071	35,13
11,50	10,00	142	94	1	15978	7,92	16,50	12,70	184	125	1	15990	20,01	21,50	12,70	210	150	1	66933	38,74
12,00	10,00	151	101	1	15979	8,65	17,00	12,70	184	125	1	15991	20,01	22,00	12,70	210	150	1	17072	38,74
12,50	10,00	151	101	1	15980	9,38	17,50	12,70	191	130	1	15992	22,77	22,50	12,70	210	150	1	66934	42,38
13,00	10,00	151	101	1	15981	9,64	18,00	12,70	191	130	1	15993	23,98	23,00	12,70	210	150	1	36364	42,38
13,50	12,70	160	108	1	15982	13,03	18,50	12,70	198	135	1	15994	26,46	23,50	12,70	220	160	1	66935	46,77
14,00	12,70	160	108	1	15984	13,83	19,00	12,70	198	135	1	15995	26,46	24,00	12,70	220	160	1	36365	46,77
14,50	12,70	169	114	1	15985	14,77	19,50	12,70	205	140	1	15996	28,83	24,50	12,70	220	160	1	66936	50,98
15,00	12,70	169	114	1	15987	14,92	20,00	12,70	205	140	1	15997	33,21	25,00	12,70	220	160	1	36366	50,98

Línea 1m
1007

BROCA MANGO REBAJADO HSS

HSS Reduced Shank Drill Bit
Foret queue reduite HSS



∅	12	12,5	13	13,5	14	15	15,5	16	16,5	17	17,5	18	18,5	19	19,5	20
Pcs	2	2	2	2	2	2	2	2	2	2	2	2	2	2	2	2

Ref. 4995 - Nº Art. 70951: **612,43 €**

Display
18

BROCA MANGO REBAJADO HSS

HSS Reduced Shank Drill Bit
Foret queue reduite HSS



∅	17	17,5	18	18	18,5	19	19,5	20
Pcs	2	2	1	1	1	1	1	1
∅	14	14	14,5	15	15,5	16	16	16,5
Pcs	2	1	2	2	2	1	1	2
∅	10,5	11	11,5	12	12	12,5	13	13,5
Pcs	2	2	2	2	1	2	2	2

Ref. 4995 - Nº Art. 22352: **593,56 €**

Ref. **1012**

BROCA MANGO CILÍNDRICO HSS

HSS Straight Shank Drill Bit
Foret queue cylindrique HSS



HSS	DIN 338 H			
Cobre Copper Cuivre	Bronce Bronze	Latón Brass Laiton		

D mm	L mm	I mm		Nº Art.	€	D mm	L mm	I mm		Nº Art.	€
1,00	34	12	10	10586	2,49	7,50	109	69	10	10625	6,36
1,25	38	16	10	27590	2,80	7,75	117	75	10	19022	13,62
1,50	40	18	10	10589	2,48	8,00	117	75	10	10628	6,77
2,00	49	24	10	10592	2,22	8,25	117	75	10	19031	12,71
2,25	53	27	10	18908	2,36	8,50	117	75	10	10631	7,85
2,50	57	30	10	10595	2,04	9,00	125	81	10	10634	8,26
2,75	61	33	10	18917	2,77	9,50	125	81	10	10637	9,68
3,00	61	33	10	10598	2,26	9,75	133	87	10	19040	21,68
3,25	65	36	10	18932	2,77	10,00	133	87	10	10640	10,09
3,50	70	39	10	10601	2,42	10,50	133	87	5	10643	12,11
*3,75	70	39	10	18941	3,60	11,00	142	94	5	10646	13,50
4,00	75	43	10	10604	2,64	11,50	142	94	5	10649	16,33
4,25	75	43	10	18953	3,93	12,00	151	101	5	10652	17,60
4,50	80	47	10	10607	3,23	12,50	151	101	5	10655	19,96
4,75	80	47	10	18968	5,12	13,00	151	101	5	10658	21,40
5,00	86	52	10	10610	3,50	14,00	160	108	1	18863	32,65
5,20	86	52	10	18974	5,37	14,50	169	114	1	46846	46,88
5,25	86	52	10	18977	5,28	15,00	169	114	1	54158	48,28
5,50	93	57	10	10613	4,26	16,00	178	120	1	46847	51,31
*5,75	93	57	10	18980	6,47	16,50	184	125	1	46848	52,76
6,00	93	57	10	10616	4,60	17,00	184	125	1	46849	54,38
6,25	101	63	10	18986	6,47	18,00	191	130	1	54159	57,74
6,50	101	63	10	10619	5,12	18,50	198	135	1	46851	59,25
6,75	109	69	10	18998	7,79	19,00	198	135	1	46852	61,11
7,00	109	69	10	10622	5,41	20,00	205	140	1	46850	64,52
7,25	109	69	10	19013	10,30						

* Diam. hasta fin de existencias / while stock lasts / jusqu'à la fin de stock





Ref. **1025**

BROCA MANGO CILÍNDRICO CORTE IZQUIERDA

Left Hand Straight Shank Twist Drill
Foret queue cylindrique coupe à gauche



HSS
Aceros <850 N/mm²
Steel / Aciers

DIN 338 N
Fundición
Cast Iron
Fonte

Aluminio
Aluminium

D mm	L mm	I mm		Nº Art.	€
1,00	34	12	10	10554	3,32
1,50	40	18	10	10560	3,32
2,00	49	24	10	10562	3,02
2,50	57	30	10	10564	3,02
3,00	61	33	10	10569	2,29
3,50	70	39	10	11121	2,68
4,00	75	43	10	11566	3,02
4,50	80	47	10	11811	3,43
5,00	86	52	10	11817	3,71
5,50	93	57	10	11820	4,93
6,00	93	57	10	12001	5,08
6,50	101	63	10	12330	5,92

D mm	L mm	I mm		Nº Art.	€
7,00	109	69	10	12336	7,19
7,50	109	69	10	12339	7,56
8,00	117	75	10	12345	8,65
8,50	117	75	10	12348	9,32
9,00	125	81	10	12399	11,35
9,50	125	81	10	12408	12,39
10,00	133	87	10	12417	13,33
11,00	142	94	5	70015	21,47
12,00	151	101	5	70016	25,52
13,00	151	101	5	70017	32,19

Sets
1025

BROCA MANGO CILÍNDRICO CORTE IZQUIERDA

Left Hand Straight Shank Twist Drill
Foret queue cylindrique coupe à gauche



Set **1462**

6 Pcs

Cont. Ø	Nº Art.	€
2 - 3 - 4 - 5 - 6 - 8 mm	67380	26,59



Set **1466**

19 Pcs

Cont. Ø	Nº Art.	€
1 - 10 x 0,5 mm	66659	115,79

Ref. **1660**

BROCA MANGO CILÍNDRICO HSS DOBLE

Double HSS Straight Shank Drill Bit
Foret queue cylindrique HSS double



Aceros
<850 N/mm²
Steel / Aciers



D mm	L mm	I mm		Nº Art.	€
2,00	38	9	10	16028	1,75
2,20	40	9	10	27607	1,61
2,30	43	10	10	25604	2,08
2,50	43	10	10	16034	1,74
2,80	46	13	10	16040	1,63
2,90	46	13	10	16043	1,63
3,00	46	13	10	16046	1,51
3,10	52	14	10	16049	1,51
3,20	52	14	10	16052	1,51
3,25	52	14	10	16055	1,51
3,30	52	14	10	16058	1,51
3,40	52	14	10	16061	1,69
3,50	52	14	10	16064	1,69
3,70	55	15	10	16067	1,88
3,75	55	15	10	16070	1,93
3,80	55	15	10	16073	1,88
4,00	55	15	10	16076	1,74
4,10	58	16	10	16079	1,88
4,20	58	16	10	16082	1,88
4,25	58	16	10	16085	1,88

D mm	L mm	I mm		Nº Art.	€
4,50	58	16	10	16088	1,93
4,75	62	18	10	16094	3,13
4,80	62	18	10	16097	2,14
4,90	62	18	10	16100	2,14
5,00	62	18	10	16103	2,21
5,10	66	19	10	16106	3,02
5,20	66	19	10	16109	3,02
5,25	66	19	10	16112	3,13
5,50	66	19	10	16115	2,68
5,70	66	19	10	25634	3,55
5,75	66	19	10	16121	3,70
6,00	66	19	10	16127	3,00
6,50	70	21	10	16133	3,31
7,00	74	24	10	16136	3,95
7,40	74	24	10	25664	5,43
7,50	74	24	10	16139	4,04
8,00	79	25	10	16142	4,83
9,00	84	25	10	16148	6,46
10,00	89	27	10	16154	6,95



Ref. **1050**

BROCA MANGO CILÍNDRICO HSS EXTRA CORTA

HSS Straight Shank Stub Drill Bit

Foret queue cylindrique HSS extra-courte



HSS

DIN 1897 N

Serie Extra Corta
 Stub Series
 Série extra-courte

Aceros
 <850 N/mm²
 Steel / Aciers

Fundición
 Cast Iron
 Fonte

Aluminio
 Aluminium



D mm	L mm	I mm	Nº Art.	€
1,00	26	6	10 20606	1,11
1,25	30	8	10 20615	0,97
1,50	32	9	10 12302	0,97
1,60	34	10	10 12305	1,12
1,75	36	11	10 12311	1,11
1,80	36	11	10 12314	1,12
1,90	36	11	10 12317	1,12
2,00	38	12	10 12320	0,96
2,10	40	13	10 12323	1,01
2,20	40	13	10 12326	1,01
2,25	40	13	10 12329	0,87
2,30	40	13	10 12332	1,01
2,40	43	14	10 12335	1,01
2,50	43	14	10 12338	0,77
2,60	43	14	10 12341	0,94
2,70	46	16	10 12344	0,94
2,75	46	16	10 12347	0,83
2,80	46	16	10 12350	0,95
2,90	46	16	10 12353	0,95
3,00	46	16	10 12356	0,83
3,10	49	18	10 12359	0,89
3,20	49	18	10 12362	0,89
3,25	49	18	10 12365	0,89
3,30	49	18	10 12368	0,89
3,40	52	20	10 12371	1,01
3,50	52	20	10 12374	0,89
3,60	52	20	10 12377	1,12
3,70	52	20	10 12380	1,12
3,75	52	20	10 12383	0,98
3,80	55	22	10 12386	1,12
3,90	55	22	10 12389	1,12
4,00	55	22	10 12392	0,98
4,10	55	22	10 12395	1,16
4,20	55	22	10 12398	1,16
4,25	55	22	10 12401	1,16
4,30	58	24	10 12404	1,32
4,40	58	24	10 12407	1,32
4,50	58	24	10 12410	1,16
4,60	58	24	10 20636	1,50
4,70	58	24	10 20639	1,50
4,75	58	24	10 12413	1,29
4,80	62	26	10 12416	1,50
4,90	62	26	10 12419	1,50
5,00	62	26	10 12422	1,29

D mm	L mm	I mm	Nº Art.	€
5,10	62	26	10 12425	1,64
5,20	62	26	10 12428	1,64
5,25	62	26	10 12431	1,43
5,30	62	26	10 12434	1,65
5,40	66	28	10 12437	1,65
5,50	66	28	10 12440	1,43
5,60	66	28	10 12443	1,90
5,70	66	28	10 12446	1,90
5,75	66	28	10 12449	1,63
5,80	66	28	10 12452	1,90
5,90	66	28	10 12455	1,90
6,00	66	28	10 12458	1,63
6,10	70	31	10 20651	2,22
6,20	70	31	10 20654	2,22
6,25	70	31	10 12461	1,94
6,30	70	31	10 20657	2,22
6,40	70	31	10 20663	2,22
6,50	70	31	10 12464	1,94
6,60	70	31	10 20666	2,60
6,70	70	31	10 20669	2,60
6,75	74	34	10 12467	2,24
6,80	74	34	10 20672	2,24
7,00	74	34	10 12470	2,24
7,20	74	34	10 20681	2,90
7,25	74	34	10 27317	2,55
7,40	74	34	10 30591	2,80
7,50	74	34	10 12473	2,55
7,75	79	37	10 12476	2,80
7,80	79	37	10 20696	3,22
8,00	79	37	10 12479	2,80
8,25	79	37	10 12482	3,33
8,50	79	37	10 12485	3,33
8,75	84	40	10 12488	3,65
9,00	84	40	10 12491	3,65
9,10	84	40	10 30592	4,55
9,25	84	40	10 12494	4,08
9,50	84	40	10 12497	4,08
9,75	89	43	10 27334	4,55
10,00	89	43	10 12500	4,55
10,20	89	43	1 20756	5,15
10,25	89	43	1 12503	5,71
10,50	89	43	1 12506	5,15
11,00	95	47	1 12512	5,71
11,10	95	47	1 30593	6,72

D mm	L mm	I mm	Nº Art.	€
11,25	95	47	1 12515	6,35
11,50	95	47	1 12518	6,35
12,00	102	51	1 12527	6,72
12,25	102	51	1 12530	7,56
12,50	102	51	1 12533	7,56
12,70	102	51	1 20813	7,95
13,00	102	51	1 12539	8,25
13,50	107	54	1 12545	10,49
14,00	107	54	1 12551	11,33
14,50	111	56	1 12554	12,94
15,00	111	56	1 12557	14,79
15,50	115	58	1 12560	17,82
16,00	115	58	1 12563	17,82
16,50	119	60	1 12566	20,97
17,00	119	60	1 12569	20,97
17,50	123	62	1 12572	23,37
18,00	123	62	1 12575	23,37
18,50	127	64	1 12578	26,01
19,00	127	64	1 12581	26,01
19,50	131	66	1 12584	31,20
20,00	131	66	1 12587	31,20

Set **1476**



19 Pcs

Cont. Ø	Nº Art.	€
1 - 10 x 0,5 mm	11935	56,12

Ref. **1030**

BROCA MANGO CILÍNDRICO HSS LARGA

HSS Straight Shank Long Drill Bit
Foret queue cylindrique HSS longue



HSS **DIN 340 N** **118°** **Serie Larga Long Series Série longue**

Aceros <850 N/mm² Steel / Aciers **Fundición Cast Iron Fonte** **Aluminio Aluminium**



D mm	L mm	I mm		Nº Art.	€
0,50	32	12	10	26656	5,28
0,60	35	15	10	26658	4,29
0,70	42	21	10	19467	4,29
0,80	46	25	10	24592	4,29
0,90	51	29	10	26659	4,29
1,00	56	33	10	11573	4,34
1,10	60	37	10	11576	4,22
1,20	65	41	10	11579	4,22
1,25	65	41	10	11582	4,35
1,30	65	41	10	11585	4,22
1,40	70	45	10	11588	4,22
1,50	70	45	10	11591	3,13
1,60	76	50	10	11594	4,22
1,70	76	50	10	11597	4,22
1,75	80	53	10	11600	3,49
1,80	80	53	10	11603	3,35
1,90	80	53	10	11606	3,35
2,00	85	56	10	11609	2,22
2,10	85	56	10	11612	3,06
2,20	90	59	10	11615	3,06
2,25	90	59	10	11618	2,44
2,30	90	59	10	11621	2,94
2,40	95	62	10	11624	2,94
2,50	95	62	10	11627	2,22
2,60	95	62	10	11630	2,94
2,70	100	66	10	11633	2,94
2,75	100	66	10	11636	3,06
2,80	100	66	10	11639	2,94
2,90	100	66	10	11642	2,94
3,00	100	66	10	11645	2,07
3,10	106	69	10	11648	2,29
3,20	106	69	10	11651	2,29
3,25	106	69	10	11654	2,29
3,30	106	69	10	11657	2,29
3,40	112	73	10	11660	2,94
3,50	112	73	10	11663	2,17
3,60	112	73	10	11666	2,94
3,70	112	73	10	11669	2,94
3,75	112	73	10	11672	3,06
3,80	119	78	10	11675	3,67
3,90	119	78	10	11678	3,67
4,00	119	78	10	11681	2,35
4,10	119	78	10	11684	3,08
4,20	119	78	10	11687	3,08

D mm	L mm	I mm		Nº Art.	€
4,25	119	78	10	11690	3,08
4,30	126	82	10	11693	3,97
4,40	126	82	10	11696	3,97
4,50	126	82	10	11699	2,80
4,60	126	82	10	11702	3,97
4,70	126	82	10	19955	3,97
4,75	126	82	10	11705	4,14
4,80	132	87	10	11708	4,59
4,90	132	87	10	11711	4,59
5,00	132	87	10	11714	3,01
5,10	132	87	10	11717	4,59
5,20	132	87	10	11720	4,59
5,25	132	87	10	11723	4,76
5,30	132	87	10	11726	4,99
5,40	139	91	10	11729	4,99
5,50	139	91	10	11732	3,96
5,60	139	91	10	11735	4,99
5,70	139	91	10	11738	4,99
5,75	139	91	10	11741	5,19
5,80	139	91	10	11744	5,50
5,90	139	91	10	11747	5,50
6,00	139	91	10	11750	3,68
6,10	148	97	10	11753	5,50
6,20	148	97	10	11756	5,50
6,25	148	97	10	11759	5,70
6,30	148	97	10	11762	5,56
6,40	148	97	10	11765	5,56
6,50	148	97	10	11768	4,71
6,60	148	97	10	11771	5,56
6,70	148	97	10	11774	5,56
6,75	156	102	10	11777	5,76
6,80	156	102	10	11780	5,76
6,90	156	102	10	11783	5,90
7,00	156	102	10	11786	5,49
7,10	156	102	10	11789	5,90
7,20	156	102	10	11792	5,90
7,25	156	102	10	11795	6,13
7,30	156	102	10	11798	6,02
7,40	156	102	10	11801	6,02
7,50	156	102	10	11804	5,84
7,60	165	109	10	11807	6,02
7,70	165	109	10	11810	6,02
7,75	165	109	10	11813	6,25
7,80	165	109	10	11816	6,74

Ref. **1030**

BROCA MANGO CILÍNDRICO HSS LARGA

HSS Straight Shank Long Drill Bit

Foret queue cylindrique HSS longue



D mm	L mm	I mm		Nº Art.	€
7,90	165	109	10	11819	6,74
8,00	165	109	10	11822	6,51
8,10	165	109	5	11825	6,74
8,20	165	109	5	11828	6,74
8,25	165	109	5	11831	6,99
8,30	165	109	5	11834	10,35
8,40	165	109	5	11837	10,35
8,50	165	109	5	11840	7,24
8,60	175	115	5	11843	10,35
8,70	175	115	5	11846	10,35
8,75	175	115	5	11849	10,77
8,80	175	115	5	11852	10,58
8,90	175	115	5	11855	10,58
9,00	175	115	5	11858	7,87
9,10	175	115	5	11861	10,58
9,20	175	115	5	11864	10,58
9,25	175	115	5	11867	11,00
9,30	175	115	5	11870	11,40
9,40	175	115	5	11873	11,40
9,50	175	115	5	11876	7,97
9,60	184	121	5	11879	11,40
9,70	184	121	5	11882	11,40
9,75	184	121	5	11885	11,82
9,80	184	121	5	11888	11,40
9,90	184	121	5	11891	11,40
10,00	184	121	5	11894	8,61
10,20	184	121	1	11900	11,63
10,25	184	121	1	11903	10,77
10,50	184	121	1	11912	11,63
10,75	195	128	1	11921	11,82
10,80	195	128	1	11924	14,79
11,00	195	128	1	11930	12,93
11,10	195	128	1	30588	17,29
11,25	195	128	1	11939	15,37
11,50	195	128	1	11948	13,18
11,75	195	128	1	11957	17,29

D mm	L mm	I mm		Nº Art.	€
11,80	195	128	1	11960	17,29
11,90	205	134	1	11963	17,29
12,00	205	134	1	11966	14,73
12,20	205	134	1	11972	16,66
12,25	205	134	1	11975	16,71
12,30	205	134	1	11978	19,69
12,50	205	134	1	11984	15,51
12,75	205	134	1	11993	20,46
13,00	205	134	1	12002	17,60
13,25	214	140	1	12005	20,46
13,50	214	140	1	12008	19,65
13,75	214	140	1	12011	20,52
14,00	214	140	1	12014	21,21
14,25	220	144	1	12017	38,20
14,50	220	144	1	12020	24,84
14,75	220	144	1	12023	38,20
15,00	220	144	1	12026	24,02
15,25	227	149	1	12029	43,14
15,50	227	149	1	12032	35,66
15,75	227	149	1	12035	43,14
16,00	227	149	1	12038	27,96
16,25	235	154	1	12041	47,61
16,50	235	154	1	12044	33,08
16,75	235	154	1	12047	47,61
17,00	235	154	1	12050	33,23
17,25	241	158	1	12053	54,74
17,50	241	158	1	12056	49,12
17,75	241	158	1	12059	63,83
18,00	241	158	1	12062	34,65
18,25	247	162	1	12065	75,19
18,50	247	162	1	12068	53,66
19,00	247	162	1	12074	43,42
19,50	254	166	1	12080	83,54
19,75	254	166	1	12083	94,34
20,00	254	166	1	12086	48,74

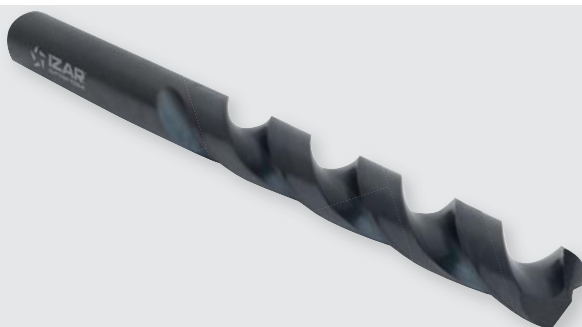

Ref. **1003**

BROCA MANGO CILÍNDRICO HSS LARGA

HSS Straight Shank Long Drill Bit
Foret queue cylindrique HSS longue



HSS

DIN
340 N



Serie Larga
Long Series
Série longue

Aceros
<850 N/mm²
Steel / Aciers

Fundición
Cast Iron
Fonte

Aluminio
Aluminium



D mm	L mm	I mm		Nº Art.	€
2,00	85	56	1	10572	2,60
2,50	95	62	1	10573	2,60
3,00	100	66	1	10581	2,42
3,25	106	69	1	10582	2,68
3,50	112	73	1	10584	2,44
4,00	119	78	1	10585	2,67
4,25	119	78	1	10591	3,47
4,50	126	82	1	10593	3,16
5,00	132	87	1	10596	3,39
5,50	139	91	1	10599	4,49
6,00	139	91	1	10602	4,17
6,50	148	97	1	10605	5,12
7,00	156	102	1	10608	6,00
7,50	156	102	1	10611	6,36
8,00	165	109	1	10614	7,12
8,50	165	109	1	10617	7,89
9,00	175	115	1	10620	8,56
10,00	184	121	1	10623	9,12
11,00	195	128	1	10629	13,69
12,00	205	134	1	10632	15,61
13,00	205	134	1	10635	18,66



**Línea 1m
1003**

BROCA MANGO CILÍNDRICO HSS LARGA

HSS Straight Shank Long Drill Bit
Foret queue cylindrique HSS longue



∅	2	2,5	3	3,25	3,5	4	4,25	4,5	5	5,5	6	6,5	7	7,5	8	8,5	9	10	12
Pcs	5	5	5	5	5	5	5	5	5	5	5	5	5	3	5	3	3	5	2

Ref. 4995 - N° Art. 71682: 406,89 €

**Display
15**

BROCA MANGO CILÍNDRICO HSS LARGA

HSS Straight Shank Long Drill Bit
Foret queue cylindrique HSS longue



∅	7,5	8	8,5	9	10	11	12	13		
Pcs	5	5	3	3	3	2	2	2		
∅	4,25	4,25	4,5	5	5	5,5	6	6	6,5	7
Pcs	3	2	5	3	2	3	3	2	5	5
∅	2	2,5	3	3	3,25	3,25	3,5	3,5	4	4
Pcs	5	5	3	2	3	2	3	2	3	2

Ref. 4995 - N° Art. 22328: 457,10 €

Ref. **1040**

BROCA MANGO CILÍNDRICO HSS EXTRA LARGA

HSS Straight Shank Extra Long Drill Bit
Foret queue cylindrique HSS extra-longue



HSS

DIN
1869 N



Serie Extra Larga
Extra Long Series
Série extra-longue

Aceros
<850 N/mm²
Steel / Aciers

Fundición
Cast Iron
Fonte

Aluminio
Aluminium



D mm	L mm	I mm		Nº Art.	€
2,00	125	85	1	12158	10,16
2,50	140	95	1	12161	10,61
3,00	150	100	1	12164	11,00
3,00	190	136	1	12167	12,71
3,50	165	115	1	12170	12,41
3,50	210	145	1	12173	14,30
3,50	265	180	1	12176	20,46
4,00	175	120	1	12179	12,41
4,00	220	150	1	12182	14,61
4,00	280	190	1	12185	20,85
4,50	185	125	1	12188	13,75
4,50	235	160	1	12191	17,16
4,50	295	200	1	12194	24,57
5,00	195	135	1	12197	14,52
5,00	245	170	1	12200	18,46
5,00	315	210	1	12203	22,69
5,50	205	140	1	12206	17,19
5,50	260	180	1	12209	24,57
5,50	330	225	1	12212	28,35
6,00	205	140	1	12215	17,19
6,00	260	180	1	12218	24,57
6,00	330	225	1	12221	28,35
6,50	215	150	1	12224	20,46
6,50	275	190	1	12227	26,41

D mm	L mm	I mm		Nº Art.	€
6,50	350	235	1	12230	32,90
7,00	225	155	1	12233	21,66
7,00	290	200	1	12236	30,17
7,00	370	250	1	12239	40,78
7,50	225	155	1	12242	24,40
7,50	290	200	1	12245	32,50
7,50	370	250	1	12248	47,35
8,00	240	165	1	12251	26,95
8,00	305	210	1	12254	37,34
8,00	390	265	1	12257	48,65
8,50	240	165	1	12260	36,69
8,50	305	210	1	12263	49,99
8,50	390	265	1	12266	68,75
9,00	250	175	1	12269	34,97
9,00	320	220	1	12272	46,19
9,00	410	280	1	12275	67,82
9,50	250	175	1	12278	41,21
9,50	320	220	1	12281	56,63
9,50	410	280	1	12284	76,29
10,00	265	185	1	12287	40,66
10,00	340	235	1	12290	53,20
10,00	430	295	1	12293	73,91
11,00	280	195	1	28866	51,48
12,00	295	205	1	28867	67,97



Ref. **1090**

BROCA MANGO CILÍNDRICO HSS LAMINADA

HSS Straight Shank Rolled Drill Bit
Foret queue cylindrique HSS laminé



HSS

Laminada
Rolled
Laminé



D mm	L mm	I mm		Nº Art.	€
1,00	34	12	10	21440	0,30
1,50	40	18	10	21446	0,30
2,00	49	24	10	21452	0,30
2,50	57	30	10	21458	0,30
3,00	61	33	10	21464	0,30
3,25	65	36	10	21470	0,37
3,50	70	39	10	21473	0,42
4,00	75	43	10	21482	0,42

D mm	L mm	I mm		Nº Art.	€
4,25	75	43	10	21485	0,50
4,50	80	47	10	21488	0,50
5,00	86	52	10	21494	0,53
5,50	93	57	10	21503	0,59
6,00	93	57	10	21509	0,62
6,50	101	63	10	21518	0,67
7,00	109	69	10	21527	0,95
7,50	109	69	10	21533	1,01

D mm	L mm	I mm		Nº Art.	€
8,00	117	75	10	21542	1,10
8,50	117	75	10	21548	1,28
9,00	125	81	10	21554	1,60
10,00	133	87	10	21566	1,74
11,00	142	94	5	21581	2,22
12,00	151	101	5	21593	2,44
13,00	151	101	5	21608	2,86

Ref. **1009**

BROCA MANGO CILÍNDRICO HSS LAMINADA

HSS Straight Shank Rolled Drill Bit
Foret queue cylindrique HSS laminé



HSS

Laminada
Rolled
Laminé



D mm	L mm	I mm		Nº Art.	€
1,00	34	12	2	30173	0,83 *
1,50	40	18	2	30175	0,83 *
2,00	49	24	2	30177	0,86 *
2,50	57	30	2	30179	0,86 *
3,00	61	33	2	30181	0,86 *
3,25	65	36	2	30182	0,98 *
3,50	70	39	2	30183	1,05 *
4,00	75	43	2	30185	1,05 *

D mm	L mm	I mm		Nº Art.	€
4,25	75	43	1	30186	0,69
4,50	80	47	1	30187	0,76
5,00	86	52	1	30189	0,76
5,50	93	57	1	30191	0,83
6,00	93	57	1	30193	0,90
6,50	101	63	1	30195	0,94
7,00	109	69	1	30197	1,05
7,50	109	69	1	30199	1,22

D mm	L mm	I mm		Nº Art.	€
8,00	117	75	1	30201	1,39
8,50	117	75	1	30203	1,56
9,00	125	81	1	30205	1,65
10,00	133	87	1	30209	2,05
11,00	142	94	1	30213	2,64
12,00	151	101	1	30217	3,22
13,00	151	101	1	30221	3,56

* € = 2 uds.



Set **1490**

6 Pcs

Cont. Ø	Nº Art.	€
2 - 3 - 4 - 5 - 6 - 8 mm	30204	4,50



Set **1491**

19 Pcs

Cont. Ø	Nº Art.	€
1 - 10 x 0,5 mm	30206	17,91



Set **1492**

25 Pcs

Cont. Ø	Nº Art.	€
1 - 13 x 0,5 mm	30210	35,95



Set **1499**

170 Pcs

Cont. Ø	Nº Art.	€
1-10 x 0,5 mm Ø 1-8: 10 pcs/Ø Ø 8,5-10: 5 pcs/Ø	69084	123,03

Ref.

1110**BROCA MANGO CÓNICO HSS**HSS Morse Taper Shank Drill Bit
Foret queue cône morse HSS

HSS

DIN
345 NAceros
<850 N/mm²
Steel / AciersAceros
<1000 N/mm²
Steel / AciersFundición
Cast Iron
FonteCobre
Copper
Cuivre

D	L	I	CM	N° Art.	€	D	L	I	CM	N° Art.	€	D	L	I	CM	N° Art.	€
mm	mm	mm				mm	mm	mm				mm	mm	mm			
5,00	133	52	1	14426	13,13	16,50	223	125	2	14564	28,65	28,00	291	170	3	14702	72,11
5,25	133	52	1	14429	15,10	16,75	223	125	2	14567	32,96	28,25	296	175	3	14705	88,93
5,50	138	57	1	14432	13,13	17,00	223	125	2	14570	28,65	28,50	296	175	3	14708	77,32
5,75	138	57	1	14435	15,10	17,25	228	130	2	14573	36,46	28,75	296	175	3	14711	88,93
6,00	138	57	1	14438	13,13	17,50	228	130	2	14576	31,70	29,00	296	175	3	14714	77,32
6,25	144	63	1	14441	17,21	17,75	228	130	2	14579	36,46	29,25	296	175	3	14717	97,78
6,50	144	63	1	14444	13,97	18,00	228	130	2	14582	30,50	29,50	296	175	3	14720	85,02
6,75	150	69	1	14447	16,07	18,25	233	135	2	14585	40,12	29,75	296	175	3	14723	97,78
7,00	150	69	1	14450	13,97	18,50	233	135	2	14588	34,90	30,00	296	175	3	14726	85,02
7,25	150	69	1	14453	18,48	18,75	233	135	2	14591	40,12	30,25	301	180	3	14729	108,81
7,50	150	69	1	14456	15,03	19,00	233	135	2	14594	34,90	30,50	301	180	3	14732	94,61
7,75	156	75	1	14459	18,48	19,25	238	140	2	14597	43,67	30,75	301	180	3	14735	108,81
8,00	156	75	1	14462	14,98	19,50	238	140	2	14600	37,97	31,00	301	180	3	14738	94,61
8,25	156	75	1	14465	21,69	19,75	238	140	2	14603	43,67	31,25	301	180	3	14741	115,23
8,50	156	75	1	14468	16,29	20,00	238	140	2	14606	37,97	31,50	301	180	3	14744	100,19
8,75	162	81	1	14471	19,49	20,25	243	145	2	14609	45,27	31,75	306	185	3	14747	115,23
9,00	162	81	1	14474	16,29	20,50	243	145	2	14612	39,37	32,00	334	185	4	14750	100,19
9,25	162	81	1	14477	21,56	20,75	243	145	2	14615	45,27	32,50	334	185	4	14753	114,45
9,50	162	81	1	14480	16,09	21,00	243	145	2	14618	39,37	33,00	334	185	4	14756	114,45
9,75	168	87	1	14483	21,56	21,25	248	150	2	14621	49,94	33,50	334	185	4	14759	124,44
10,00	168	87	1	14486	15,80	21,50	248	150	2	14624	43,41	34,00	339	190	4	14762	124,44
10,25	168	87	1	14489	20,18	21,75	248	150	2	14627	49,94	34,50	339	190	4	14765	135,98
10,50	168	87	1	14492	17,53	22,00	248	150	2	14630	43,41	35,00	339	190	4	14768	135,98
10,75	175	94	1	14495	20,18	22,25	248	150	2	14633	54,64	35,50	339	190	4	14771	145,91
11,00	175	94	1	14498	17,53	22,50	253	155	2	14636	47,52	36,00	344	195	4	14774	145,91
11,25	175	94	1	14501	21,22	22,75	253	155	2	14639	54,64	36,50	344	195	4	14777	153,80
11,50	175	94	1	14504	18,46	23,00	253	155	2	14642	47,52	37,00	344	195	4	14780	153,80
11,75	175	94	1	14507	21,22	23,25	276	155	3	14645	60,29	37,50	344	195	4	14783	161,77
12,00	182	101	1	14510	18,46	23,50	276	155	3	14648	52,42	38,00	349	200	4	14786	161,77
12,25	182	101	1	14513	23,62	23,75	281	160	3	14651	60,29	38,50	349	200	4	14789	172,53
12,50	182	101	1	14516	19,76	24,00	281	160	3	14654	52,42	39,00	349	200	4	14792	172,53
12,75	182	101	1	14519	23,62	24,25	281	160	3	14657	65,76	39,50	349	200	4	14795	182,17
13,00	182	101	1	14522	20,56	24,50	281	160	3	14660	57,16	40,00	349	200	4	14798	182,17
13,25	189	108	1	14525	25,99	24,75	281	160	3	14663	65,76	40,50	354	205	4	14801	191,56
13,50	189	108	1	14528	21,71	25,00	281	160	3	14666	57,16	41,00	354	205	4	14804	191,56
13,75	189	108	1	14531	25,99	25,25	286	165	3	14669	71,54	41,50	354	205	4	14807	203,26
14,00	189	108	1	14534	21,71	25,50	286	165	3	14672	62,19	42,00	354	205	4	14810	203,26
14,25	212	114	2	14537	28,14	25,75	286	165	3	14675	71,54	42,50	354	205	4	14813	213,22
14,50	212	114	2	14540	24,49	26,00	286	165	3	14678	62,19	43,00	359	210	4	14816	213,22
14,75	212	114	2	14543	28,14	26,25	286	165	3	14681	77,45	43,50	359	210	4	14819	223,22
15,00	212	114	2	14546	24,49	26,50	286	165	3	14684	67,36	44,00	359	210	4	14822	223,22
15,25	218	120	2	14549	29,14	26,75	291	170	3	14687	77,45	44,50	359	210	4	14825	233,07
15,50	218	120	2	14552	25,33	27,00	291	170	3	14690	67,36	45,00	359	210	4	14828	233,07
15,75	218	120	2	14555	29,14	27,25	291	170	3	14693	82,90	45,50	364	215	4	14831	242,91
16,00	218	120	2	14558	25,33	27,50	291	170	3	14696	72,11	46,00	364	215	4	14834	242,91
16,25	223	125	2	14561	32,96	27,75	291	170	3	14699	82,90	46,50	364	215	4	14837	252,78

Ref.

1110**BROCA MANGO CÓNICO HSS**HSS Morse Taper Shank Drill Bit
Foret queue cône morse HSS

D mm	L mm	I mm	CM	Nº Art.	€
47,00	364	215	4	14840	252,78
47,50	364	215	4	14843	261,29
48,00	369	220	4	14846	261,29
48,50	369	220	4	14849	271,32
49,00	369	220	4	14852	271,32
49,50	369	220	4	14855	281,18
50,00	369	220	4	14858	281,18
51,00	412	225	5	14864	331,93
52,00	412	225	5	14867	353,90
53,00	412	225	5	14870	377,62
54,00	417	230	5	14873	417,57
55,00	417	230	5	14876	412,02
56,00	417	230	5	14879	465,08
57,00	422	235	5	14882	492,12
58,00	422	235	5	14885	495,19
59,00	422	235	5	14888	511,14
60,00	422	235	5	14891	485,98
61,00	427	240	5	14894	568,82
62,00	427	240	5	14897	592,44
63,00	427	240	5	14900	626,52

D mm	L mm	I mm	CM	Nº Art.	€
64,00	432	245	5	14903	661,03
65,00	432	245	5	14906	634,82
66,00	432	245	5	14909	713,47
67,00	432	245	5	14912	736,51
68,00	437	250	5	14915	755,62
69,00	437	250	5	14918	779,08
70,00	437	250	5	14921	738,69

>70 mm bajo demanda
upon request / sur demande

71,00	437	250	5	14924	852,84
72,00	442	255	5	14927	870,51
73,00	442	255	5	14930	893,31
74,00	442	255	5	14933	919,43
75,00	442	255	5	14936	866,07
76,00	447	260	5	14939	1.019,83
77,00	514	260	6	14942	1.094,40
78,00	514	260	6	14945	1.115,77
79,00	514	260	6	14948	1.138,24
80,00	514	260	6	14951	1.200,83

D mm	L mm	I mm	CM	Nº Art.	€
81,00	519	265	6	14954	1.322,12
82,00	519	265	6	14957	1.355,15
83,00	519	265	6	14960	1.381,16
84,00	519	265	6	14963	1.410,48
85,00	519	265	6	14966	1.445,33
86,00	524	270	6	14969	1.476,88
87,00	524	270	6	14972	1.508,27
88,00	524	270	6	14975	1.547,03
89,00	524	270	6	14978	1.576,94
90,00	524	270	6	14981	1.622,11
91,00	529	275	6	14984	1.710,85
92,00	529	275	6	14987	1.720,69
93,00	529	275	6	14990	1.782,07
94,00	529	275	6	14993	1.818,29
95,00	529	275	6	14996	1.855,65
96,00	534	280	6	14999	1.916,80
97,00	534	280	6	15002	1.932,86
98,00	534	280	6	15005	1.975,97
99,00	534	280	6	15008	2.011,71
100,00	534	280	6	15011	2.050,07

**Set 25 Pcs**

Cont. Ø	Nº Art.	€
14-14,5-15-15,5-16-16,5-17-17,5-18-18,5-19-19,5-20-20,5-21-21,5-22-22,5-23-24-25-26-27-28-30 mm	14263	1.154,77

**Set 10 Pcs**

Cont. Ø	Nº Art.	€
14-15-16-17-18-19-20-21-22-25 mm	19346	386,99

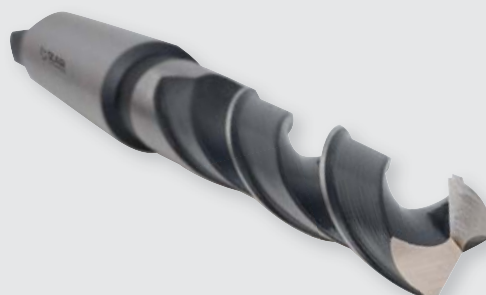

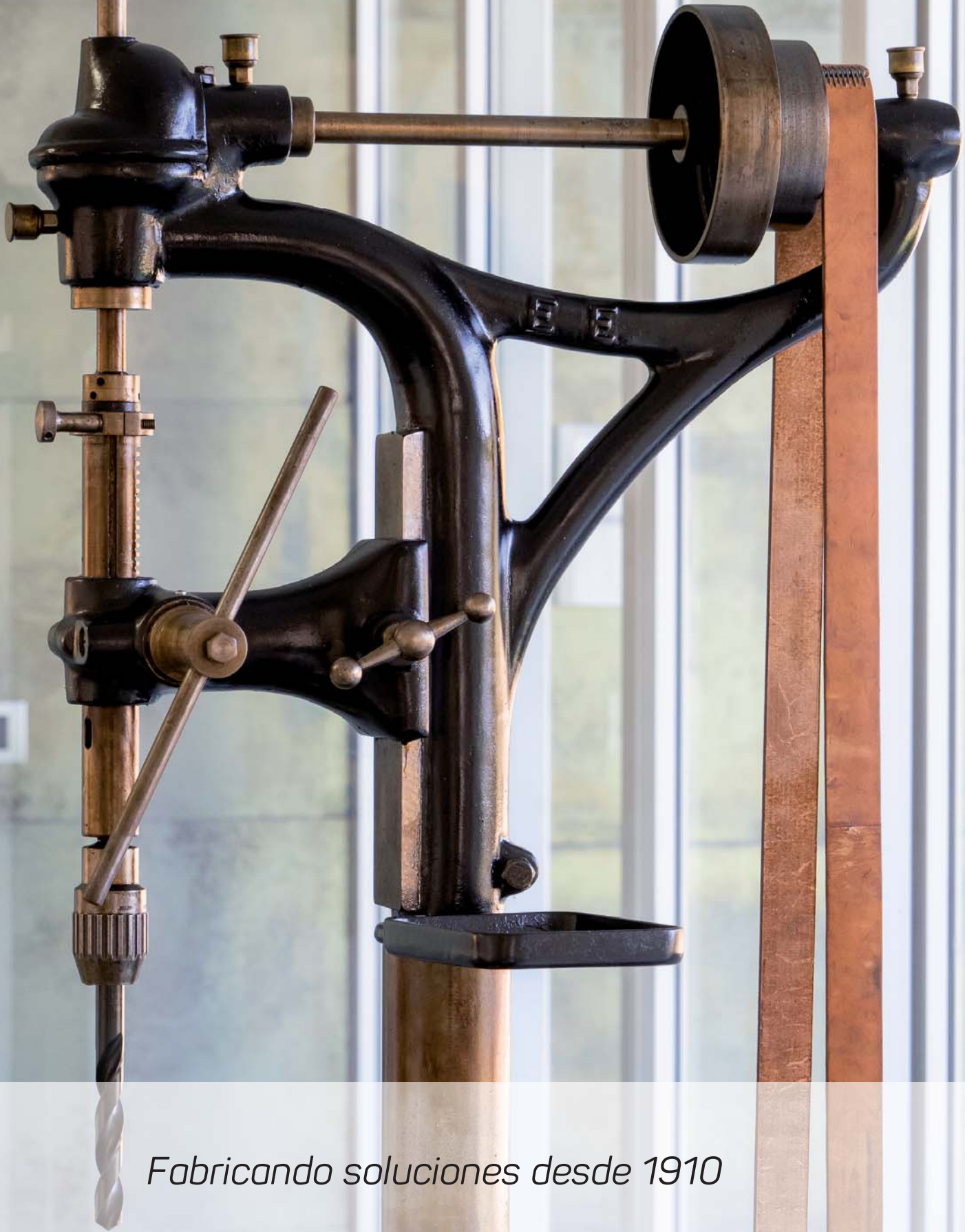

Fabricando soluciones desde 1910

izartool.com

PORTABROCAS Y ACCESORIOS

Drill Chucks & Accessories

Mandrins et accessoires

Ref. **1802**

PORTABROCAS TALADROS PORTÁTILES CON LLAVE

Portable Drilling Machine Metal Drill-Chucks with Key

Mandrins métal perceuses portables avec clé



Mod. Monoblock

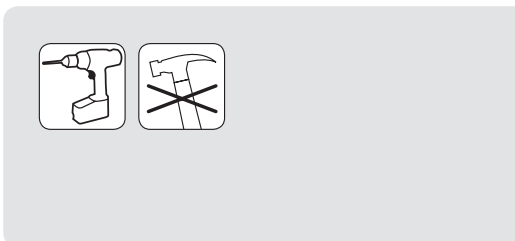

- 1 única pieza
- Elimina roturas de dientes
- Ideal taladro portátil
- Cierre con llave
- Cuerpo metal
- Agujero interior
- Only one piece
- No teeth breaking
- Ideal portable drills
- Key-lock
- Metal body
- Internal hole
- 1 Seule pièce
- Pas de casse de dents
- Perçuses à main
- Fermeture à clé
- Corps Métal
- Trou intérieur

Monoblock

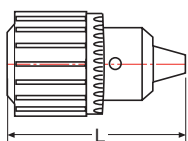

Mod.	Cap. mm	Fijación Fix.	L mm	Peso Weight Poids gr.	Nº Art.	€
00102	1-10	1/2X20 UNF	60	299	47491	17,13
00131	1,5-13	3/8X24 UNF	77	501	47493	18,92

2 Pcs.

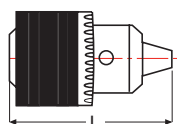

Mod.	Cap. mm	Fijación Fix.	L mm	Peso Weight Poids gr.	Nº Art.	€
00101	1-10	3/8X24 UNF	60	311	47490	17,13
00132	1,5-13	1/2X20 UNF	77	492	47494	18,92

Ref. **1807**

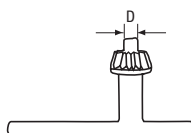

D mm	Mod.	Nº Art.	€
6	00102		
	00101	16362	3,07
	00132		
6,3	00131	69316	3,64



Ref. **1806**

PORTABROCAS TALADROS PORTÁTILES - AUTOMÁTICO METAL

Portable Drilling Machine Drill-Chucks - Metal Automatic
Mandrins perçuses portables - automatique métal



- **Cierre seguridad**
- **Capacidad 13: Garras MD**
- Ideal atornilladores
- Taladros percusión de batería
- Reversible
- Cuerpo metal ligero
- Agujero interior
- No apto martillos SDS
- **Security lock**
- **Capacity 13: carbide jaws**
- Ideal screwdrivers
- Battery percussion drills
- Reversible
- Light metal body
- Internal hole
- Not suitable SDS
- **Fermeture sureté**
- **Capacité 13: pinces carbure**
- Idéal Tournevis
- Perçuses percussion batterie
- Reversible
- Corps métal léger
- Trou intérieur
- Non apte pour SDS

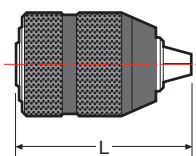

Mod.	Cap. mm	Fijación Fix.	L mm	Peso Weight Poids gr.	Nº Art.	€
00101	1-10	3/8X24 UNF	64,5	311	14706	40,09
00102	1-10	1/2X20 UNF	64,5	313	14712	40,09
00131	2-13	3/8X24 UNF	74,5	397	14718	57,80
00132	2-13	1/2X20 UNF	74,5	328	14736	57,80

Ref. **1804**

PORTABROCAS TALADROS PORTATILES Y ESTACIONARIOS

Portable & Stationary Drilling Machine Drill-Chucks
Mandrins perçuses portables et fixes



- **Cierre seguridad**
- Taladros industriales y percusión (aptos martillos alta frecuencia SDS plus)
- Autoapriete automático
- **Security lock**
- Industrial & percussion drills (suitable high frequency hammers SDS plus)
- Automatic self-tightening
- **Fermeture sureté**
- Perçuses industrielles et précisions (aptés pour marteaux haute fréquence SDS plus)
- Auto-attachement

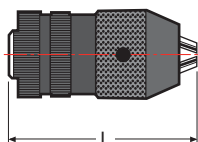

Mod.	Cap. mm	Fijación Fix.	L mm	Peso Weight Poids gr.	Nº Art.	€
00101	0-10	3/8X24 UNF	74	350	16358	72,12
00132	1-13	1/2X20 UNF	96	670	16361	77,66

Ref. **1803**

PORTABROCAS PRECISIÓN TALADROS PORTATILES Y ESTACIONARIOS

Portable & Stationary Drilling Machine Precision Drill-Chucks

Mandrins précision perceuses portables et fixes



→
Derecha
Right - Droite



- Uso Taladros industriales y profesionales
- Fijaciones: Rosca taladro portátil y Cónica taladro fijo
- Autoapriete automático
- Giro a derechas

- Use for Industrial & professional drills
- Fixing: Threaded portable drills & Tapered for fixed drills
- Automatic self-tightening
- Right turning

- Usage perceuses industrielles et professionnelles
- Fixations: Filet perceuse portable et conique perceuse à colonne
- Amenchement automatique
- Tour à droite

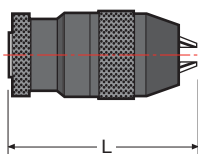

Mod.	Cap. mm	Fijación Fix.	L mm	Peso Weight Poids gr.	N° Art.	€	Garras Jaws Pincas Art.
00101	0,8-10	B12 *	86	619	16349	65,59	56894
00102	0,8-10	3/8X24 UNF	78	451	16350	65,59	56894
00103	0,8-10	1/2X20UNF	78	452	16351	65,59	56894
00131	1-13	B16 *	103	800	16352	70,60	24565
00132	2-13	3/8X24 UNF	83	764	16353	70,60	56894
00133	2-13	1/2X20 UNF	83	583	16354	70,60	56894
00161	3-16	B16	105	1.180	16355	120,12	24565
00162	3-16	B18 *	105	1.152	16356	120,12	24565
00163	3-16	1/2X20 UNF	105	1.185	16357	120,12	24565
00164	5-20	B18 *	131	2.165	19957	151,61	24566

*** RECOMENDACIONES:**

1. Limpiar muy bien la espiga y el agujero del portabrocas antes de introducir la espiga.
2. Cogiendo el porta-brocas en una mano, insertar la espiga con la otra mano.
3. Dar un pequeño golpe seco con una maza de Nylon.

*** RECOMMENDATIONS:**

1. Thoroughly clean the spindle and the chuck-hole before inserting the spindle.
2. Holding the chuck in one hand, insert the spike with the other hand.
3. Give a small heavy thud with a Nylon mace.

*** RECOMMANDATIONS :**

1. Nettoyez soigneusement l'arbre d'attache et le trou du mandrin avant d'insérer l'arbre.
2. En tenant le mandrin d'une main, insérez l'arbre avec l'autre main.
3. Donnez un petit coup sec avec une masse en nylon.

Ref. **1809**

ACCESORIOS

Accessories
Accessoires

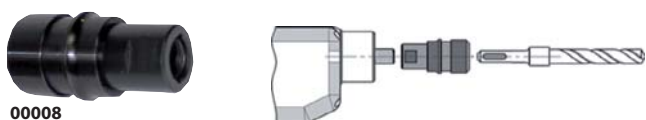

Conversores / Converters / Convertisseurs

Mod.	Entrada Inlet Entrée	Fijación Fix	Nº Art.	€
00001	3/8X24h	3/8X24h	16363	3,56
00002	3/8X24h	1/2X20h	16364	4,17
00003	SDS plus	1/2X20h	16365	19,74
00004	SDS max	SDS plus	17258	112,92
00005	Hex. 13 mm	SDS plus	17259	122,44
00008	1/2x20h	SDS plus	20485	61,10

Tornillos / Screws / Vis

Mod.	Entrada Inlet Entrée	Fijación Fix		Nº Art.	€
00010	M5x18 mm	3/8x24	1	25321	0,40
00011	M6x25 mm	1/2x20	1	25323	0,40

Ref. **1819**

GARRAS

Jaws
Pinces



Mod.	Garras Jaws Pinces	Nº Art.	€
1013ROS	10/13 mm ROSCA (Ref. 1803)	56894	34,87
13DIN16	13DIN / 16 mm (Ref. 1803)	24565	36,71
16	16 mm	24566	37,12

Display 12

PORTABROCAS TALADROS PORTATILES Y ESTACIONARIOS

Portable & Stationary Drilling Machine Drill-Chucks
Mandrins perçuses portables et fixes



∅	Ref. 1802 Cap. 1-10 Fix. 1/2 x 20h	Ref. 1802 Cap. 1,5-13 Fix. 1/2 x 20h	Ref. 1806 Cap. 1-10 Fix. 1/2 x 20h	Ref. 1806 Cap. 1-10 Fix. 1/2 x 20h	Ref. 1806 Cap. 2-13 Fix. 1/2 x 20h	Ref. 1806 Cap. 2-13 Fix. 1/2 x 20h
Pcs	2	2	1	1	1	1
∅	Ref. 1803 Cap. 0,8-10 Fix. 1/2 x 20h	Ref. 1803 Cap. 2-13 Fix. 1/2 x 20h	Ref. 1804 Cap. 1-13 Fix. 1/2 x 20h	Ref. 1804 Cap. 1-13 Fix. 1/2 x 20h	Ref. 1809 SDS plus Mod. 00003	Ref. 1807 Llave Key - Clé D 6 mm
Pcs	2	2	1	1	5	5

Ref. 4995 - Nº Art. 22334: 809,66 €

Línea 1m 18PB

PORTABROCAS TALADROS PORTATILES Y ESTACIONARIOS

Portable & Stationary Drilling Machine Drill-Chucks
Mandrins perçuses portables et fixes



∅	Ref. 1802 Cap. 1-10 Fix 1/2 x 20h	Ref. 1802 Cap. 1,5-13 Fix 1/2 x 20h	Ref. 1803 Cap. 0,8-10 Fix 1/2 x 20h	Ref. 1803 Cap. 2-13 Fix 1/2 x 20h	Ref. 1804 Cap. 1-13 Fix 1/2 x 20h	Ref. 1804 Cap. 1-13 Fix 1/2 x 20h	Ref. 1806 Cap. 1-10 Fix 1/2 x 20h	Ref. 1806 Cap. 2-13 Fix 1/2 x 20h	Ref. 1807 Llave Key - Clé D 6 mm	Ref. 1809 SDS plus Fix 1/2 x 20h
Pcs	2	2	2	2	1	1	2	2	3	5

Ref. 4995 - Nº Art. 72080: 803,52 €

Línea 33 cm 18PB

PORTABROCAS TALADROS PORTATILES Y ESTACIONARIOS

Portable & Stationary Drilling Machine Drill-Chucks
Mandrins perçuses portables et fixes



∅	Ref. 1802 Cap. 1,5-13 Fix 1/2 x 20h	Ref. 1803 Cap. 0,8-10 Fix 1/2 x 20h	Ref. 1803 Cap. 2-13 Fix 1/2 x 20h	Ref. 1806 Cap. 1-10 Fix. 1/2 x 20h	Ref. 1806 Cap. 2-13 Fix 1/2 x 20h
Pcs	2	2	2	2	2

Ref. 4995 - Nº Art. 72081: 506,02 €

Ref. **1101**

CONO REDUCTOR

Reduction Sleeve
Douille de réduction



HSS

DIN
2185

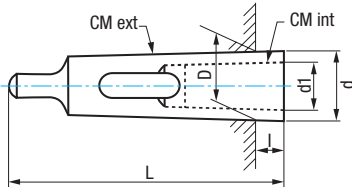

CM EXT.	CM INT.	L mm	I mm	D mm	d1 mm	d mm	Nº Art.	€
2	1	92	17,00	17,780	12,065	18,60	16415	17,75
3	1	99	5,00	23,825	12,065	24,10	16416	24,33
3	2	112	18,00	23,825	17,780	24,70	16417	24,68
4	1	124	6,50	31,267	12,065	31,60	16418	38,74
4	2	124	6,50	31,267	17,780	31,60	16419	38,74
4	3	140	22,50	31,267	23,825	32,40	16420	38,74
5	3	156	6,50	44,399	23,825	44,70	16421	59,58
5	4	171	21,50	44,399	31,267	45,50	16422	59,81



Ref. **1102**

ALARGADOR CONOS

Extension Socket
Douille d'augmentation



HSS

DIN
2187

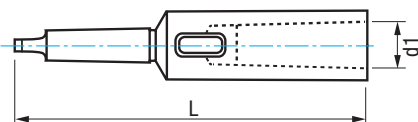

CM EXT.	CM INT.	L mm	d1 mm	Nº Art.	€
1	2	160	17,78	16423	42,92
2	1	159	12,07	16427	33,24
2	2	176	17,78	16433	44,01
2	3	195	23,83	16424	56,69
3	1	176	12,07	16428	35,45
3	2	194	17,78	16429	41,80
3	3	215	23,83	16434	64,05
3	4	239	31,27	16425	85,04
4	1	200	12,07	16430	59,30
4	2	215	17,78	16431	59,95
4	3	240	23,83	16432	69,83
4	4	265	31,27	16435	100,91
4	5	299	44,39	16426	199,80



Ref. **1103**

ESPIGA SUJECIÓN

Spike CM Taper
Arbre d'attachement



HSS

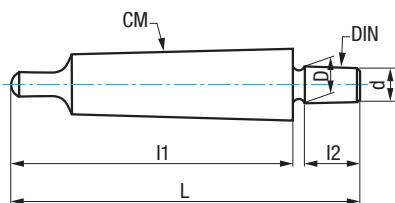

CM	DIN	L mm	l1 mm	D mm	d mm	l2 mm		Nº Art.	€
1	B12	89,00	62,00	12,065	11,10	18,50	1	16440	11,21
2	B12	106,00	75,00	12,065	11,10	18,50	1	16441	12,10
2	B16	111,00	75,00	15,733	14,50	24,00	1	16442	12,10
2	B18	118,00	75,00	17,780	16,20	32,00	1	16443	12,10
3	B12	126,00	94,00	12,065	11,10	18,50	1	16444	14,71
3	B16	134,00	94,00	15,733	14,50	24,00	1	16445	14,71
3	B18	140,00	94,00	17,780	16,20	32,00	1	21873	14,71
4	B16	158,00	117,50	15,733	14,50	24,00	1	16446	22,58
4	B18	166,50	117,50	17,780	16,20	32,00	1	16447	22,58
5	B16	194	149,50	15,733	14,50	24,00	1	66764	64,36
5	B18	202	149,50	17,780	16,20	32,00	1	66765	64,36



Ref. **1104**

CUÑA EXPULSORA

Drill Drift
Chasse cône standard



HSS

CM Ext. min.	CM Ext. max.	L mm		Nº Art.	€
1	2	116	1	16436	10,59
2	3	150	1	16437	12,80
3	4	199	1	16438	16,97
4	5	251	1	16439	22,92



Ref. **9994**

MÁQUINA AFILADORA BROCAS

Drill Bit Sharpening Machine
Machine affûteuse forets



Mod. **XP**



Mod.	Cap. mm	Punta Point Pointe	Uso Use Usage	Nº Art.	€
XP	2,5-13	118°	HSS, TIN, MD/HM + Split Point	38416	151,90

*Incluida Muela / Wheel included / Compris meule

Mod. **500**



Mod.	Cap. mm	Punta Point Pointe	Uso Use Usage	Nº Art.	€
500	2,5-13	118°-135°	HSS, TIN, HSSE, MD/HM, Pared Masonry / Béton + Split Point	45121	308,85

*Incluida Muela / Wheel included / Compris meule K180

Mod. **750**



Mod.	Cap. mm	Punta Point Pointe	Uso Use Usage	Nº Art.	€
750	2,5-19	115°-140°	HSS, TIN, HSSE, MD/HM + Split Point	38418	353,62

*Incluida Muela / Wheel included / Compris meule K180

PIEZAS RECAMBIO - Spare Parts - Pieces rechange

Porta Brocas - Drill Chucks - Mandrins

Mod.	Cap. mm	Punta Point Pointe	Nº Art.	€
XP	2,5-13	118°	39712	70,25
500	2,5-13	118°-135°	47218	70,25
500-750	2,5-19	115°-140°	40343	98,51

Muela - Wheel - Meule

Mod.	Grano Grain	Máquina Machine	Cap. mm	Nº Art.	€
K180	Fino Fine Fin	XP-500-750	2,5-19	40344	49,16
K100	Grueso Coarse Gros	750	13-19	43414	49,16

BROCAS ESPECIALES

Special Drill Bits

Forets Spéciales

Ref. **1602**

BROCA ESCALONADA HSS

HSS Step Drill Bit
Foret étagé HSS



- Nueva punta robusta autocentrante
- Avellanado especial 45°
- Menor desgaste y esfuerzo de corte
- Mayor rendimiento y vida útil de la herramienta
- Mejor evacuación de viruta
- Acabado sin rebabas
- New autocentering robust point
- Special 45° Counterboring
- Lower wear and cutting effort
- Better performance & longer tool life
- Better chipping-off
- No-burr finishing
- Nouvelle pointe plus robuste autocentrante
- Ébavurage special à 45°
- Réduction de l'usure et de l'effort de coupe
- Augmentation de la performance et vie utile de l'outil
- Meilleure évacuation des copeaux
- Finition sans bavures

HSS

118°

45°

< 4 mm

Chapa
Sheets
Tôle

Materiales ferrosos
Ferrous Materials
Matériaux ferreux

Aceros
<850 N/mm²
Steel / Aciers

Plásticos
Plastics
Plastiques



Cap. mm	Nº Pasos Steps / Étages	d mm	L mm	Nº Art.	€
4-12	9 (4-5-6-7-8-9-10-11-12)	6	79	12048	38,31
4-20	9 (4-6-8-10-12-14-16-18-20)	9	67	12054	48,71
4-30	14 (4-6-8-10-12-14-16-18-20-22-24-26-28-30)	10	100	66484	64,43
6-30	13 (6-8-10-12-14-16-18-20-22-24-26-28-30)	10	100	12060	71,59
7-37	8 (7-12,5-15,2-18,6-20,4-22,5-28,3-37)	12	90	67619	139,66
9-36	10 (9-12-15-18-21-24-27-30-33-36)	12	82	12066	128,79
12-20	9 (12-13-14-15-16-17-18-19-20)	9	75	56798	53,12
20-30	11 (20-21-22-23-24-25-26-27-28-29-30)	12	88	56799	77,44
30-40	11 (30-40x1)	13	98	60715	116,25
40-50	11 (40-50x1)	13	112	60716	180,18
50-60	11 (50-60x1)	13	120	60717	269,59



Set 3 Pcs

Cont.	Nº Art.	€
4-12, 4-20, 6-30 mm	43518	158,61

Expo
1602

EXPOSITOR BROCAS ESCALONADAS

Step Drill Display
Présentoirs Forets Étagés

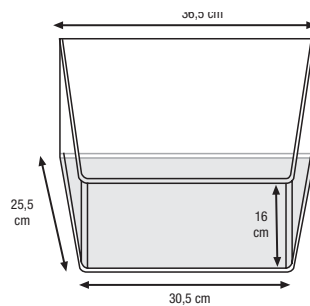

15 Pcs

Nº Art. €

65184 1.401,94

Cap. mm	Nº Art.	Uds.
4-12	12048	2
4-20	12054	2
6-30	12060	2
9-36	12066	2
12-20	56798	2
20-30	56799	2
30-40	60715	1
40-50	60716	1
50-60	60717	1

Línea 33 cm
1602

BROCA ESCALONADA HSS

HSS Step Drill Bit
Foret étagé HSS



ø	4-12	4-20	4-30	6-30	9-36	12-20
Pcs	1	1	1	1	1	1

Ref. 4995 - Nº Art. 70954: 404,95 €



Ref. **1612**

BROCA ESCALONADA **ESPIRAL** HSS

HSS **Spiral** Step Drill Bit
Foret étagé **spirale** HSS



- Canal optimizado para virutas largas y complejas
- Avellanado especial 45°
- Filos de corte protegidos y muy afilados
- Sin rebabas
- Mayor vida útil en materiales muy duros
- Autocentrado en chapas finas
- Optimized channel for long and complex chips
- Special 45° Counterboring
- Very sharpened & protected cutting edges
- No burrs
- Longer tool life in very hard materials
- Autocentering in fine sheets
- Goujure optimisée pour copeaux longs et complexes
- Ébavurage special à 45°
- Filets des arêtes de coupe protégés et plus affûtés
- Sans bavures
- Vie utile plus longue pour aciers plus durs
- Autocentrage sur toles minces

HSS

118°

Spiral

45°

< 4 mm

Chapa
Sheets
Tôle

Materiales ferrosos
Ferrous Materials
Matériaux ferreux

Aceros
<850 N/mm²
Steel / Aciers

Plásticos
Plastics
Plastiques



Cap. mm	Nº Pasos Steps / Étages	d mm	L mm	Nº Art.	€
4-12	9 (4-5-6-7-8-9-10-11-12)	6	80	67360	39,87
4-20	9 (4-6-8-10-12-14-16-18-20)	9	69	67366	56,58
6-30	13 (6-8-10-12-14-16-18-20-22-24-26-28-30)	10	99	67368	82,28
6-38	12 (6-9-13-16-19-21-23-26-29-32-35-38)	12	97	69557	161,82



Set 3 Pcs

Cont.	Nº Art.	€
4-12, 4-20, 6-30 mm	67357	178,73

Línea 33 cm
1612

BROCA ESCALONADA **ESPIRAL** HSS

HSS **Spiral** Step Drill Bit
Foret étagé **spirale** HSS



∅	4-12	4-20	6-30	6-38
Pcs	1	1	1	1

Ref. 4995 - Nº Art. 70958: **340,55 €**

Ref. **1607**

BROCA ESCALONADA HSSE INOX

Stainless HSSE Step Drill Bit
Foret étagé HSSE Inox



- Nueva punta robusta autocentrante
- Avellanado especial 45°
- Menor desgaste y esfuerzo de corte
- Mayor rendimiento y vida útil de la herramienta
- Mejor evacuación de viruta
- Acabado sin rebabas

- New autocentering robust point
- Special 45° Counterboring
- Lower wear and cutting effort
- Better performance & longer tool life
- Better chipping-off
- No-burr finishing

- Nouvelle pointe plus robuste autocentrante
- Ébavurage special à 45°
- Réduction de l'usure et de l'effort de coupe
- Augmentation de la performance et vie utile de l'outil
- Meilleure évacuation des copeaux
- Finition sans bavures

HSSE 5% Co						Chapa Sheets Tôle	Materiales ferrosos Ferrous Materials Matériaux ferreux
---------------	--	--	--	--	--	-------------------------	---

Aceros <850 N/mm ² Steel / Aciers	INOX Stainless Steel Acier INOX	Cobre Copper Cuivre	Aluminio Aluminium	Plásticos Plastics Plastiques
--	---------------------------------------	---------------------------	-----------------------	-------------------------------------



Cap. mm	Nº Pasos Steps / Étages	d mm	L mm	Nº Art.	€
4-12	9 (4-5-6-7-8-9-10-11-12)	6	79	12072	45,96
4-20	9 (4-6-8-10-12-14-16-18-20)	8	67	12078	58,46
6-30	13 (6-8-10-12-14-16-18-20-22-24-26-28-30)	10	100	12084	85,91
9-36	10 (9-12-15-18-21-24-27-30-33-36)	12	82	67299	154,55
12-20	9 (12-13-14-15-16-17-18-19-20)	9	75	60835	63,75
20-30	11 (20-21-22-23-24-25-26-27-28-29-30)	12	88	60837	92,92
30-40	11 (30-40x1)	13	98	60838	145,31
40-50	11 (40-50x1)	13	112	60839	216,22
50-60	11 (50-60x1)	13	120	60840	323,51



Set 3 Pcs

Cont.	Nº Art.	€
4-12, 4-20, 6-30 mm	43519	190,32

Línea 33 cm
1607

BROCA ESCALONADA HSSE INOX

Stainless HSSE Step Drill Bit
Foret étagé HSSE Inox



∅	4-12	4-20	6-30	9-36	12-20
Pcs	1	1	1	1	1

Ref. 4995 - Nº Art. 70961: 408,64 €



Ref. **1617**

BROCA ESCALONADA **ESPIRAL HSSE INOX**

Stainless HSSE Spiral Step Drill Bit

Foret étagé spirale HSSE Inox



- Canal optimizado para virutas largas y complejas
- Avellanado especial 45°
- Filos de corte protegidos y muy afilados
- Sin rebabas
- Mayor vida útil en materiales muy duros
- Autocentrado en chapas finas
- Optimized channel for long and complex chips
- Special 45° Counterboring
- Very sharpened & protected cutting edges
- No burrs
- Longer tool life in very hard materials
- Autocentering in fine sheets
- Goujure optimisée pour copeaux longs et complexes
- Ébavurage special à 45°
- Filets des arêtes de coupe protégés et plus affûtés
- Sans bavures
- Vie utile plus longue pour aciers plus durs
- Autocentrage sur toles minces

HSSE
5% Co



Chapa
Sheets
Tôle

Materiales ferrosos
Ferrous Materials
Matériaux ferreux

Aceros
<850 N/mm²
Steel / Aciers

INOX
Stainless Steel
Acier INOX

Cobre
Copper
Cuivre

Aluminio
Aluminium

Plásticos
Plastics
Plastiques



Cap. mm	Nº Pasos* Steps* / Étages*	d mm	L mm	Nº Art.	€
4-12	9 (4-5-6-7-8-9-10-11-12)	6	80	67314	47,86
4-20	9 (4-6-8-10-12-14-16-18-20)	9	69	67316	67,91
6-30	13 (6-8-10-12-14-16-18-20-22-24-26-28-30)	10	99	67318	98,72



Set 3 Pcs

Cont.	Nº Art.	€
4-12, 4-20, 6-30 mm	67317	214,49

Línea 33 cm
1617

BROCA ESCALONADA **ESPIRAL HSSE INOX**

Stainless HSSE Spiral Step Drill Bit

Foret étagé spirale HSSE Inox



ø	4-12	4-20	6-30
Pcs	1	1	1

Ref. 4995 - Nº Art. 70964: 214,49 €

Ref. **1603**

BROCA TUBO/CHAPA

Tube-Sheet Drill Bit
Foret ampli-trou



- Nueva geometría
- Menor desgaste, mayor vida útil de la herramienta
- Mayor velocidad de corte
- Materia prima de última generación
- New geometry
- Lower wear and longer tool life
- Higher cutting speed
- Last generation raw material
- Nouvelle Géométrie
- Réduction de l'usure, vie plus longue de l'outil
- Augmentation de la vitesse de coupe
- Matière première dernière génération



< 4 mm

Chapa
Sheets
Tôle

Metal no ferroso
Non-Ferrous Metal
Métal non ferreux

Aceros
<850 N/mm²
Steel / Aciers

Plásticos
Plastics
Plastiques



Cap. mm	d mm	L mm	Nº Art. HSS	€	Cap. mm	d mm	L mm	Nº Art. HSS	€
3-14	6	60	12090	15,10	26-40	12	85	69922	85,76
4-25,4	10	90	69921	40,55	36-50	12	97	12100	125,11
5-20	8	66	69920	25,09	40-61*	13	103	12102	208,75
8-20	8	62	69924	21,70	46-60	13	96	69923	208,75
16-30,5	10	72	12096	41,44					

* Cap. hasta fin de existencias / while stock lasts / jusqu'à la fin de stock

Línea 33 cm
1603

BROCA TUBO/CHAPA

Tube-Sheet Drill Bit
Foret ampli-trou



∅	3-14	4-25,4	5-20	16-30,5	36-50
Pcs	1	1	1	1	1

Ref. 4995 - Nº Art. 72084: 247,29 €



Ref. **1609**

BROCA TUBO/CHAPA

Tube-Sheet Drill Bit
Foret ampli-trou



- Nueva geometría
- Menor desgaste, mayor vida útil de la herramienta
- Mayor velocidad de corte
- Materia prima de última generación

- New geometry
- Lower wear and longer tool life
- Higher cutting speed
- Last generation raw material

- Nouvelle Géométrie
- Réduction de l'usure, vie plus longue de l'outil
- Augmentation de la vitesse de coupe
- Matière Première dernière génération

HSSE 5% Co			Chapa Sheets Tôle	Metal no ferroso Non-Ferrous Metal Métal non ferreux
Aceros <850 N/mm ² Steel / Aciers	INOX Stainless Steel Acier INOX	Plásticos Plastics Plastiques		



Cap. mm	d mm	L mm	Nº Art.	€
3-14	6	60	12108	29,35
4-30,5	10	102	69926	98,70
8-20	8	62	69925	38,87
16-30,5	10	72	12111	64,15

Línea 33 cm
1609

BROCA TUBO/CHAPA

Tube-Sheet Drill Bit
Foret ampli-trou



∅	3-14	4-30,5	8-20	16-30,5
Pcs	1	1	1	1

Ref. 4995 - Nº Art. 72087: 231,06 €

Ref. **1611**

BROCA METAL

Metal Drill Bit
Foret métal



D mm	L mm	l mm	d mm		Nº Art.	€
2,00	47	16	6,35	1	56512	3,29
3,00	47	16	6,35	1	15864	3,29
3,20	47	16	6,35	1	56515	3,29
3,25	47	16	6,35	1	15865	3,29
3,50	47	16	6,35	1	15892	3,06
4,00	53	20	6,35	1	15894	3,06
4,20	53	20	6,35	1	56516	3,06
4,25	53	20	6,35	1	15898	3,06
4,50	53	20	6,35	1	15899	2,90
5,00	59	26	6,35	1	15900	2,90
5,50	59	26	6,35	1	15902	2,89
6,00	59	26	6,35	1	15903	2,89
6,50	59	26	6,35	1	15904	2,89
7,00	59	26	6,35	1	15905	3,55
8,00	59	32	6,35	1	15906	3,55

Línea 33 cm
1611

BROCA METAL

Metal Drill Bit
Foret métal



ø	3	4	5	6	8
Pcs	5	5	5	5	5

Ref. 4995 - Nº Art. 72198: **78,48 €**

Ref. **1461**

SET BROCAS MANGO HEXAGONAL 1/4" Y PUNTAS DE ATORNILLAR

Hexagonal Shank Drill Bit and Screwdriver Bit Set
Jeu de forets hexagonales et embouts vissage



17
pcs

Brocas Metal
Metal Drill Bits
Forets Métal
3- 4 - 5 - 6 mm

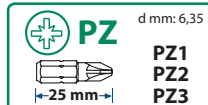
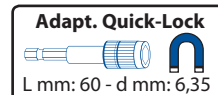
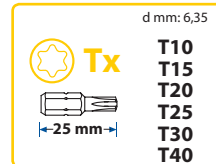

Nº Art. €
82204 **20,14**



Display
54



BROCAS METAL + PARED + MADERA

Metal + Masonry + Wood Drill Bits
Forets Métal + Maçonnerie + Bois

		Ref. 1611							
∅		2	3	3,25	3,5	4	5	6	8
Pcs		3	3	3	3	3	3	3	3

		Ref. 1610						Ref. 1601	
∅		M3	M4	M5	M6	M8	M10	4	5
Pcs		2	2	2	2	2	2	3	3

		Ref. 1601			Ref. 1621				
∅		6	8	10	3	4	5	6	8
Pcs		3	3	3	3	3	3	3	3

Ref. 4995 - N° Art. 69804: 475,64 €

Ref. 1604

BROCA CORTA PUNTOS SOLDADURA

Welding Point Jobber Drill Bit
Foret courte points soudure



HSSE
5% Co



Serie Corta
Jobber Series
Série courte

D mm	L mm	I mm	N° Art.	€
6,00	66	28	16326	10,24
8,00	80	37	16327	13,05
10,00	89	43	66909	16,34

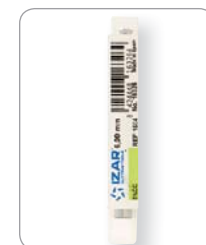

Ref. 1604 zirkonio
bajo demanda
upon request
sur demande

Ref. 1605

BROCA CORTA PUNTOS SOLDADURA

Welding Point Jobber Drill Bit
Foret courte points soudure



HSSE
8% Co



S. Extra-Corta
Stub Series
Série extra-courte

D mm	L mm	I mm	N° Art.	€
8,00	38	15	16328	16,28
8,00	45	15	16329	18,15
10,00	45	15	70687	21,60



Ref. 1605 zirkonio
bajo demanda
upon request
sur demande

Ref. 1606

BROCA FRESA

Milling Drill
Foret à découper la tôle



HSS



D mm	L mm	N° Art.	€
6,00	90	16330	12,92
8,00	95	16331	16,52



Ref. **1610**

BROCA-MACHO-AVELLANADOR

Combi Tap With Countersink
Outil multi-fonction



HSS

DIN
3126



Aceros
<850 N/mm²
Steel / Aciers

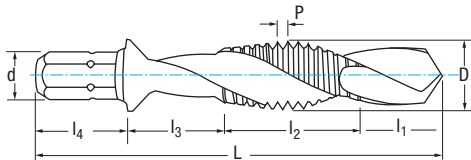

D mm	L mm	l1 mm	l2 mm	l3 mm	l4 mm	d mm	P	Avellanado Counterboring Fraisage mm	1	Nº Art.	€
M3	36	5	8	7	12	6,35	0,50	7,00	1	12567	17,15
M4	39	5	11	8	12	6,35	0,70	7,00	1	12571	17,15
M5	41	7	11	9	12	6,35	0,80	7,00	1	12577	19,23
M6	44	8	11	10	12	6,35	1,00	7,00	1	10971	25,98
M8	50	11	15	10	12	6,35	1,25	9,00	1	12582	32,71
M10	59	12	21	10	12	6,35	1,50	11,00	1	12583	44,44



Set 7 Pcs

Cont. Ø	Nº Art.	€
M3-M4-M5-M6-M8-M10-Adapt.	11025	171,69

Línea 33 cm
1610

BROCA-MACHO-AVELLANADOR

Combi Tap With Countersink
Outil multi-fonction



ø	M3	M4	M5	M6	M8
Pcs	2	2	2	2	2

Ref. 4995 - Nº Art. 72199: **224,42 €**

FRESAS HUECAS

Hole-Cutters

Fraises à carotter

Ref. **4078**

FRESA HUECA MÁQUINAS ELECTROMAGNÉTICAS TCT CORTA

Short TCT Core Drill

Fraise à carotter pour unité de perçage electromagnetique TCT courte

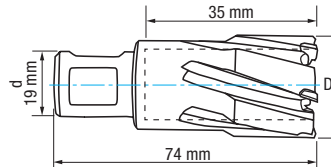

MD/HM
TCT

Serie Corta
Jobber Series
Série courte

Apto con Poca Lubricación
Suitable with Minimal Cooling
Apte avec lubrification minimale

DOBLE
WELDON

Aceros
<850 N/mm²
Steel / Aciers

INOX
Stainless Steel
Acier INOX

Fundición
Cast Iron
Fonte

Cobre
Copper
Cuivre

Latón
Brass
Laiton

Madera
Wood
Bois

D mm	d mm	L mm	l mm	Nº Art.	€	D mm	d mm	L mm	l mm	Nº Art.	€	D mm	d mm	L mm	l mm	Nº Art.	€
14	19	74	35	61963	39,87	30	19	74	35	61980	47,23	46	19	74	35	61996	107,49
15	19	74	35	61964	39,87	31	19	74	35	61981	58,71	47	19	74	35	61997	107,49
16	19	74	35	61965	39,87	32	19	74	35	61982	60,25	48	19	74	35	61998	107,49
17	19	74	35	61966	39,87	33	19	74	35	61983	60,63	49	19	74	35	61999	107,68
18	19	74	35	61967	39,87	34	19	74	35	61984	68,30	50	19	74	35	62000	111,61
19	19	74	35	61968	39,87	35	19	74	35	61985	74,93	51	19	74	35	62001	116,92
20	19	74	35	61969	39,87	36	19	74	35	61986	74,93	52	19	74	35	62002	116,92
21	19	74	35	61970	39,93	37	19	74	35	61987	74,93	53	19	74	35	62003	116,92
22	19	74	35	61971	39,93	38	19	74	35	61988	74,93	54	19	74	35	62004	116,92
23	19	74	35	61973	40,19	39	19	74	35	61989	74,93	55	19	74	35	62005	117,41
24	19	74	35	61974	40,61	40	19	74	35	61990	74,93	56	19	74	35	62006	127,47
25	19	74	35	61975	40,77	41	19	74	35	61991	86,89	57	19	74	35	62007	127,47
26	19	74	35	61976	47,23	42	19	74	35	61992	91,46	58	19	74	35	62008	127,47
27	19	74	35	61977	47,23	43	19	74	35	61993	93,25	59	19	74	35	62009	135,11
28	19	74	35	61978	47,23	44	19	74	35	61994	93,28	60	19	74	35	62010	141,91
29	19	74	35	61979	47,23	45	19	74	35	61995	93,28						

Línea 33 cm
4078

FRESA HUECA MÁQUINAS ELECTROMAGNÉTICAS TCT CORTA

Short TCT Core Drill

Fraise à carotter pour unité de perçage electromagnetique TCT courte



ø	14	16	18	20	22
Pcs	2	2	2	2	2

Ref. 4995 - Nº Art. 70967: 398,86 €

Ref. **4075**

EXPULSORES

Pilot Pins

Ejecteurs

HSS

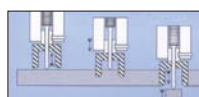

D mm	L mm	Cap. mm	Para/For/Pour Ref.	Nº Art.	€
6,34	90	12-17	4078 (35 mm)	65905	16,41
* 6,34	116	12-17	4078 (35 mm)	71750	22,39
7,98	90	18-60	4078 (35 mm)	65907	21,32
* 7,98	118	18-60	4078 (35 mm)	71880	26,87

* Para uso con adaptador
When using with adapter / Pour usage avec adaptateur

Ref. **4077**

FRESA HUECA MÁQUINAS ELECTROMAGNÉTICAS TCT LARGA

Long TCT Core Drill

Fraise à carotter pour unité de perçage electromagnetique TCT longue

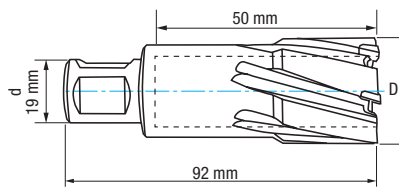

MD/HM
TCT

Serie Larga
Long Length
Série longue

Apto con Poca Lubricación
Suitable with Minimal Cooling
Apte avec lubrification minimale

DOBLE
WELDON

Aceros
<850 N/mm²
Steel / Aciers

INOX
Stainless Steel
Acier INOX

Fundición
Cast Iron
Fonte

Cobre
Copper
Cuivre

Latón
Brass
Laiton

Madera
Wood
Bois

D	d	L	l	Nº	€	D	d	L	l	Nº	€	D	d	L	l	Nº	€
mm	mm	mm	mm	Art.		mm	mm	mm	mm	Art.		mm	mm	mm	mm	Art.	
14	19	92	50	56746	56,83	30	19	92	50	56764	71,59	46	19	92	50	56780	138,71
15	19	92	50	56747	56,83	31	19	92	50	56765	86,20	47	19	92	50	56781	138,79
16	19	92	50	56749	56,83	32	19	92	50	56766	86,20	48	19	92	50	56782	138,79
17	19	92	50	56750	56,83	33	19	92	50	56767	86,20	49	19	92	50	56783	138,79
18	19	92	50	56752	56,83	34	19	92	50	56768	86,20	50	19	92	50	56784	138,79
19	19	92	50	56753	56,83	35	19	92	50	56769	86,20	51	19	92	50	56785	156,85
20	19	92	50	56754	56,83	36	19	92	50	56770	98,41	52	19	92	50	56786	157,44
21	19	92	50	56755	59,61	37	19	92	50	56771	98,77	53	19	92	50	56787	157,44
22	19	92	50	56756	59,61	38	19	92	50	56772	98,77	54	19	92	50	56788	157,44
23	19	92	50	56757	59,61	39	19	92	50	56773	98,77	55	19	92	50	56789	157,44
24	19	92	50	56758	59,69	40	19	92	50	56774	98,77	56	19	92	50	56790	172,70
25	19	92	50	56759	59,69	41	19	92	50	56775	119,15	57	19	92	50	56791	172,70
26	19	92	50	56760	71,47	42	19	92	50	56776	119,15	58	19	92	50	56792	172,70
27	19	92	50	56761	71,47	43	19	92	50	56777	119,15	59	19	92	50	56793	183,06
28	19	92	50	56762	71,59	44	19	92	50	56778	119,15	60	19	92	50	56794	188,26
29	19	92	50	56763	71,59	45	19	92	50	56779	119,15						

Línea 33 cm
4077

FRESA HUECA MÁQUINAS ELECTROMAGNÉTICAS TCT LARGA

Long TCT Core Drill

Fraise à carotter pour unité de perçage electromagnetique TCT longue



ø	14	16	18	20	22
Pcs	2	2	2	2	2

Ref. 4995 - Nº Art. 70970: 573,89 €

Ref. **4075**

EXPULSORES

Pilot Pins

Ejecteurs



HSS

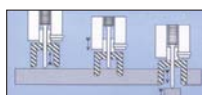

D	L	Cap.	Para/For/Pour	Nº	€
mm	mm	mm	Ref.	Art.	
6,34	106	12-17	4077 (50 mm)	61501	20,80
* 6,34	127	12-17	4077 (50 mm)	71878	17,15
7,98	105	18-60	4077 (50 mm)	61503	24,96
* 7,98	130	18-60	4077 (50 mm)	71883	31,30

* Para uso con adaptador
When using with adapter / Pour usage avec adaptateur

Ref. **4070**

FRESA HUECA MÁQUINAS ELECTROMAGNÉTICAS HSS CORTA

Short HSS Core Drill

Fraise à carotter pour unité de perçage electromagnetique HSS courte

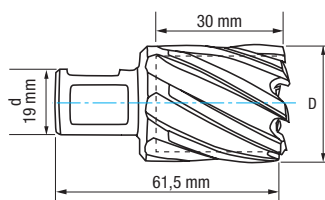

HSS	Serie Corta Jobber Series Série courte	Aceros Construcción Structural Steels Aciers de construction	Apto con Poca Lubricación Suitable with Minimal Cooling Apte avec lubrification minimale	DOBLE WELDON
Aceros <850 N/mm ² Steel / Aciers	Aceros <1000 N/mm ² Steel / Aciers	Fundición Cast Iron Fonte		



D mm	d mm	L mm	l mm	Nº Art.	€	D mm	d mm	L mm	l mm	Nº Art.	€
12	19	61,5	30	21106	24,40	37	19	61,5	30	21131	72,51
13	19	61,5	30	21107	24,40	38	19	61,5	30	21132	73,23
14	19	61,5	30	21108	25,29	39	19	61,5	30	21133	73,91
15	19	61,5	30	21109	26,35	40	19	61,5	30	21134	74,19
16	19	61,5	30	21110	27,41	41	19	61,5	30	21135	75,94
17	19	61,5	30	21111	28,28	42	19	61,5	30	21136	80,97
18	19	61,5	30	21112	29,34	43	19	61,5	30	21137	84,66
19	19	61,5	30	21113	30,06	44	19	61,5	30	21138	87,36
20	19	61,5	30	21114	31,46	45	19	61,5	30	21139	88,37
21	19	61,5	30	21115	33,59	46	19	61,5	30	21140	90,35
22	19	61,5	30	21116	34,83	47	19	61,5	30	21141	92,04
23	19	61,5	30	21117	36,25	48	19	61,5	30	21142	95,75
24	19	61,5	30	21118	37,67	49	19	61,5	30	21143	96,42
25	19	61,5	30	21119	38,90	50	19	61,5	30	21144	102,12
26	19	61,5	30	21120	40,31	51	19	61,5	30	21145	104,14
27	19	61,5	30	21121	40,66	52	19	61,5	30	21146	107,50
28	19	61,5	30	21122	43,15	53	19	61,5	30	21147	109,97
29	19	61,5	30	21123	44,57	54	19	61,5	30	21148	115,50
30	19	61,5	30	21124	45,79	55	19	61,5	30	21149	117,13
31	19	61,5	30	21125	49,86	56	19	61,5	30	21150	121,02
32	19	61,5	30	21126	53,40	57	19	61,5	30	21151	124,93
33	19	61,5	30	21127	56,23	58	19	61,5	30	21152	126,89
34	19	61,5	30	21128	64,15	59	19	61,5	30	21153	134,04
35	19	61,5	30	21129	71,00	60	19	61,5	30	21154	141,90
36	19	61,5	30	21130	71,23						



Set 6 Pcs

Cont. Ø	Nº Art.	€
12-14-16-18-20-22	66858	172,72



Set 5 Pcs

Cont. Ø	Nº Art.	€
24-26-28-30-32	66859	220,30

Línea 33 cm
4070

FRESA HUECA MÁQUINAS ELECTROMAGNÉTICAS HSS CORTA

Short HSS Core Drill

Fraise à carotter pour unité de perçage electromagnetique HSS courte



Ø	14	16	18	20	22
Pcs	2	2	2	2	2

Ref. 4995 - Nº Art. 70974: 296,64 €

Ref. **4075**

EXPULSORES

Pilot Pins

Ejecteurs

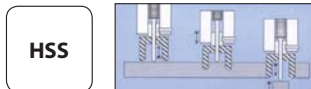

HSS

D mm	L mm	Para/For/Pour Ref.	Nº Art.	€
6,34	77	4070 (30 mm)	61502	8,86
* 6,34	102	4070 (30 mm)	61500	12,23

* Para uso con adaptador
When using with adapter
Pour usage avec adaptateur

Ref. **4071**

FRESA HUECA MÁQUINAS ELECTROMAGNÉTICAS HSS LARGA

Long HSS Core Drill

Fraise à carotter pour unité de perçage electromagnetique HSS longue

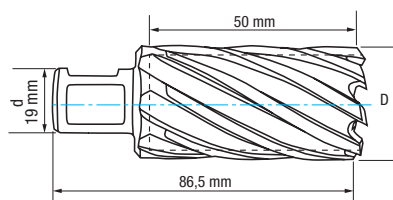

HSS	Serie Larga Long Length Série longue	Aceros Construcción Structural Steels Aciers de construction	Apto con Poca Lubricación Suitable with Minimal Cooling Apte avec lubrification minimale	Rectificado Ground Taillé meulé	DOBLE WELDON
Aceros <850 N/mm² Steel / Aciers	Aceros <1000 N/mm² Steel / Aciers	Fundición Cast Iron Fonte	Aluminio Aluminium		



D mm	d mm	L mm	l mm	Nº Art.	€	D mm	d mm	L mm	l mm	Nº Art.	€	D mm	d mm	L mm	l mm	Nº Art.	€
12	19	86,5	50	73338	33,79	28	19	86,5	50	21171	64,36	45	19	86,5	50	21189	110,50
13	19	86,5	50	73339	33,79	29	19	86,5	50	21172	66,82	46	19	86,5	50	21190	111,82
14	19	86,5	50	21157	35,03	30	19	86,5	50	21173	67,59	47	19	86,5	50	21191	118,07
15	19	86,5	50	21158	36,43	31	19	86,5	50	21174	71,00	48	19	86,5	50	21192	121,02
16	19	86,5	50	21159	38,90	32	19	86,5	50	21175	74,10	49	19	86,5	50	21193	121,68
17	19	86,5	50	21160	40,31	33	19	86,5	50	21177	77,54	50	19	86,5	50	21194	124,31
18	19	86,5	50	21161	43,33	34	19	86,5	50	21178	80,96	51	19	86,5	50	21195	131,55
19	19	86,5	50	21162	44,20	35	19	86,5	50	21179	84,39	52	19	86,5	50	21196	136,81
20	19	86,5	50	21163	45,45	36	19	86,5	50	21180	86,79	53	19	86,5	50	21197	153,24
21	19	86,5	50	21164	50,57	37	19	86,5	50	21181	90,05	54	19	86,5	50	21198	155,51
22	19	86,5	50	21165	51,99	38	19	86,5	50	21182	92,62	55	19	86,5	50	21199	157,00
23	19	86,5	50	21166	53,75	39	19	86,5	50	21183	95,37	56	19	86,5	50	21200	161,70
24	19	86,5	50	21167	55,35	40	19	86,5	50	21184	100,31	57	19	86,5	50	21201	171,80
25	19	86,5	50	21168	56,93	41	19	86,5	50	21185	101,95	58	19	86,5	50	21202	171,84
26	19	86,5	50	21169	58,71	42	19	86,5	50	21186	103,27	59	19	86,5	50	21203	181,60
27	19	86,5	50	21170	61,53	43	19	86,5	50	21187	105,91	60	19	86,5	50	21204	188,24
						44	19	86,5	50	21188	107,22						

Línea 33 cm
4071

FRESA HUECA MÁQUINAS ELECTROMAGNÉTICAS HSS LARGA

Long HSS Core Drill

Fraise à carotter pour unité de perçage electromagnetique HSS longue



ø	14	16	18	20	22
Pcs	2	2	2	2	2

Ref. 4995 - Nº Art. 70978: 429,39 €

Ref. **4075**

EXPULSORES

Pilot Pins

Ejecteurs



HSS

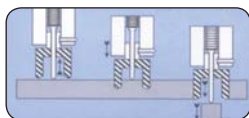

D mm	L mm	Para/For/Pour Ref.	Nº Art.	€
6,34	102	4071 (50 mm)	61500	12,23
* 6,34	127	4071 (50 mm)	71878	17,15

* Para uso con adaptador

When using with adapter / Pour usage avec adaptateur

Ref. **4072**

FRESA HUECA MÁQUINAS ELECTROMAGNÉTICAS HSS EXTRA LARGA

Extra Long HSS Core Drill

Fraise à carotter pour unité de perçage electromagnetique HSS extra-longue

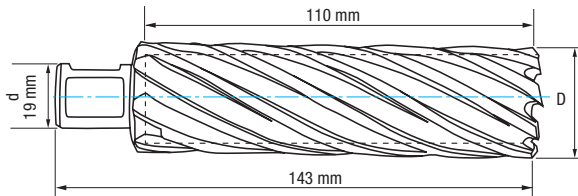

HSS

Serie Extra-Larga
Extra-Long Series
Série extra-longue

Aceros Construcción
Structural Steels
Aciers de construction

Apto con Poca Lubricación
Suitable with Minimal Cooling
Apte avec lubrification minimale

DOBLE
WELDON



Aceros
<850 N/mm²
Steel / Aciers

Aceros
<1000 N/mm²
Steel / Aciers

Fundición
Cast Iron
Fonte

Aluminio
Aluminium

D	d	L	I	Nº	€
mm	mm	mm	mm	Art.	
20	19	143	110	56694	90,73
21	19	143	110	56695	92,44
22	19	143	110	56696	94,19
23	19	143	110	56697	96,06
24	19	143	110	56698	101,77
25	19	143	110	56699	103,64
26	19	143	110	56700	114,43
27	19	143	110	56701	116,51
28	19	143	110	56702	118,80
29	19	143	110	56703	121,03
30	19	143	110	56704	123,34

D	d	L	I	Nº	€
mm	mm	mm	mm	Art.	
31	19	143	110	56706	128,68
32	19	143	110	56707	130,95
33	19	143	110	56708	140,22
34	19	143	110	56709	142,75
35	19	143	110	56710	145,37
36	19	143	110	56711	148,06
37	19	143	110	56712	151,13
38	19	143	110	56714	153,97
39	19	143	110	56715	156,88
40	19	143	110	56716	159,87
41	19	143	110	56717	187,14

D	d	L	I	Nº	€
mm	mm	mm	mm	Art.	
42	19	143	110	56718	190,27
43	19	143	110	56719	193,48
44	19	143	110	56721	196,76
45	19	143	110	56722	237,18
46	19	143	110	56724	240,40
47	19	143	110	56725	243,77
48	19	143	110	56727	247,04
49	19	143	110	56728	250,40
50	19	143	110	56730	253,81

Línea 33 cm
4072

FRESA HUECA MÁQUINAS ELECTROMAGNÉTICAS HSS EXTRA LARGA

Extra Long HSS Core Drill

Fraise à carotter pour unité de perçage electromagnetique HSS extra-longue



∅	20	22	26	32	40
Pcs	1	1	1	1	1

Ref. 4995 - Nº Art. 72090: 590,17 €

Ref. **4075**

EXPULSORES

Pilot Pins

Ejecteurs



HSS

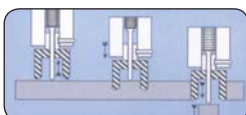

D	L	Para/For/Pour	Nº	€
mm	mm	Ref.	Art.	
7,98	154	4072 (110 mm)	61504	21,65
* 7,98	180	4072 (110 mm)	71885	32,76

* Para uso con adaptador
When using with adapter
Pour usage avec adaptateur

Ref. **4079**

BROCA MÁQUINAS ELECTROMAGNÉTICAS HSS

HSS Solid Drill

Foret pour unité de perçage electromagnetique HSS

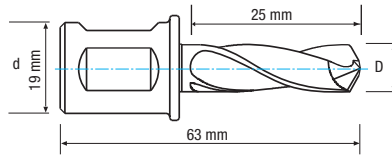

HSS

Serie Corta
Jobber Series
Série courte

Aceros Construcción
Structural Steels
Aciers de construction

Apto con Poca Lubricación
Suitable with Minimal Cooling
Apte avec lubrification minimale

DOBLE
WELDON

Aceros
<850 N/mm²
Steel / Aciers

Aceros
<1000 N/mm²
Steel / Aciers

Fundición
Cast Iron
Fonte



D mm	d mm	L mm	l mm	Nº Art.	€
6	19	63	25	69758	23,48
8	19	63	25	69761	23,48
10	19	63	25	69763	24,40
12	19	63	25	69768	27,11
14	19	63	25	69769	28,10

Línea 33 cm
4079

BROCA MÁQUINAS ELECTROMAGNÉTICAS HSS

HSS Solid Drill

Foret pour unité de perçage electromagnetique HSS



∅	6	8	10	12	14
Pcs	1	1	1	1	1

Ref. 4995 - Nº Art. 70982: 126,57 €



Ref. **4076**

AVELLANADOR MÁQUINA ELECTROMAGNÉTICA

Core Drill Countersink

Fraise à noyer pour unité de perçage electromagnetique



Aceros <850 N/mm ² Steel / Aciers	INOX Stainless Steel Acier INOX	Fundición Cast Iron Fonte	Cobre Copper Cuivre	Latón Brass Laiton	Madera Wood Bois
---	--	--	----------------------------------	---------------------------------	-------------------------------

D+ mm	D- mm	d mm	L mm	Nº Art.	€
25	3	19	45	61505	113,10
30	3	19	47	61506	113,70
40	3	19	52	61507	131,79
50	3	19	57	61508	150,03
55	3	19	60	61509	167,80

Línea 33 cm
4076

AVELLANADOR MÁQUINA ELECTROMAGNÉTICA

Core Drill Countersink

Fraise à noyer pour unité de perçage electromagnetique



ø	25	30	40	50	55
Pcs	1	1	1	1	1

Ref. 4995 - Nº Art. 72093: **676,41 €**

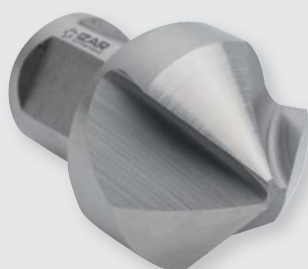

Ref. **4074**

ADAPTADOR FRESA HUECA MÁQUINA ELECTROMAGNÉTICA

Core Drill Adaptor

Adaptateur pour fraise à carotter pour unité de perçage electromagnetique



Fresa Cutter Fraise	Máquina Machine	Expulsor mm Pilot Pin Ejecteur	L mm	I mm	Nº Art.	€
Doble Weldon	Fein Quick In	6,35	51,20	28,60	61510	27,69
Doble Weldon	Fein Quick In	7,98	51,20	28,60	61511	27,69



Fresa Cutter Fraise	Máquina Machine	Expulsor mm Pilot Pin Ejecteur	L mm	I mm	Nº Art.	€
Doble Weldon	Universal	6,35	51,20	28,60	61512	27,15
Doble Weldon	Universal	7,98	51,20	28,60	61513	27,15



Entrada In Entrée	Salida Out Sortie	L mm	Nº Art.	€
Doble Weldon	1/2x20h	43	83450	28,24



Entrada In Entrée	Salida Out Sortie	L mm	Nº Art.	€
Doble Weldon	B16	57	83449	28,24











ELECCIÓN ADAPTADORES FRESAS HUECAS DOBLE WELDON

Double Weldon Core Drill Adaptor Choice

Choix d'adaptateurs pour fraises à carotter Double Weldon



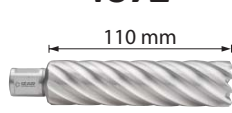







Ref. 4075		Ref. 4074		Ref. 4075			
Fresa Cutter Fraise	Expulsor sin Adaptador Pilot Pin without adapter Ejecteur sans adaptateur	Adaptador Máquina Adaptor Machine Adaptateur machine	FEIN QUICK IN	* Expulsor para uso con adaptador * Pilot Pin when using with Adapter * Ejecteur pour usage avec adaptateur			
4078 	(12-17 mm) 6,34 x 90 mm. Art. 65905	 Art. 61510		(12-17 mm) * 6,34 x 116 mm. Art. 71750			
4077 	(12-17 mm) 6,34 x 106 mm. Art. 61501			(12-17 mm) * 6,34 x 127 mm. Art. 71878			
4070 	6,34 x 77 mm. Art. 61502			* 6,34 x 102 mm. Art. 61500			
4071 	6,34 x 102 mm. Art. 61500			* 6,34 x 127 mm. Art. 71878			
4078 	(18-60 mm) 7,98 x 90 mm. Art. 65907			 Art. 61511		(18-60 mm) * 7,98 x 118 mm. rt. 71880	
4077 	(18-60 mm) 7,98 x 105 mm. Art. 61503					(18-60 mm) * 7,98 x 130 mm. Art. 71883	
4072 	7,98 x 154 mm. Art. 61504	* 7,98 x 180 mm. Art. 71885					

ELECCIÓN ADAPTADORES FRESAS HUECAS DOBLE WELDON

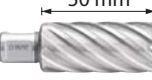
Double Weldon Core Drill Adaptor Choice

Choix d'adaptateurs pour fraises à carotter Double Weldon

Ref. 4075		Ref. 4074		Ref. 4075	
Fresa Cutter Fraise	Expulsor sin Adaptador Pilot Pin without adapter Ejecteur sans adaptateur	Adaptador Máquina Adaptor Machine Adaptateur machine	UNIVERSAL Nitto + Weldon	* Expulsor para uso con adaptador * Pilot Pin when using with Adapter * Ejecteur pour usage avec adaptateur	
4078 	(12-17 mm) 6,34 x 90 mm. Art. 65905	 Art. 61512		(12-17 mm) * 6,34 x 116 mm. Art. 71750	
4077 	(12-17 mm) 6,34 x 106 mm. Art. 61501			(12-17 mm) * 6,34 x 127 mm. Art. 71878	
4070 	6,34 x 77 mm. Art. 61502			* 6,34 x 102 mm. Art. 61500	
4071 	6,34 x 102 mm. Art. 61500			* 6,34 x 127 mm. Art. 71878	
4078 	(18-60 mm) 7,98 x 90 mm. Art. 65907	 Art. 61513		(18-60 mm) * 7,98 x 118 mm. Art. 71880	
4077 	(18-60 mm) 7,98 x 105 mm. Art. 61503			(18-60 mm) * 7,98 x 130 mm. Art. 71883	
4072 	7,98 x 154 mm. Art. 61504			* 7,98 x 180 mm. Art. 71885	

Ref. **4067**

FRESA HUECA MÁQUINAS ELECTROMAGNÉTICAS TCT LARGA

Long TCT Core Drill

Fraise à carotter pour unité de perçage electromagnetique TCT longue

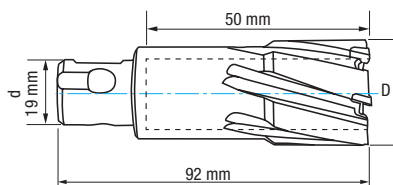

MD/HM
TCT

Serie Larga
Long Length
Série longue

Apto con Poca Lubricación
Suitable with Minimal Cooling
Apte avec lubrification minimale

UNIVERSAL:
NITTO +
WELDON

Aceros
<850 N/mm²
Steel / Aciers

INOX
Stainless Steel
Acier INOX

Fundición
Cast Iron
Fonte

Cobre
Copper
Cuivre

Latón
Brass
Laiton

Madera
Wood
Bois

D mm	d mm	L mm	l mm	Nº Art.	€	D mm	d mm	L mm	l mm	Nº Art.	€	D mm	d mm	L mm	l mm	Nº Art.	€
14	19	92	50	61248	56,83	30	19	92	50	61264	71,59	46	19	92	50	61280	138,71
15	19	92	50	61249	56,83	31	19	92	50	61265	86,20	47	19	92	50	61281	138,79
16	19	92	50	61250	56,83	32	19	92	50	61266	86,20	48	19	92	50	61282	138,79
17	19	92	50	61251	56,83	33	19	92	50	61267	86,20	49	19	92	50	61283	138,79
18	19	92	50	61252	56,83	34	19	92	50	61268	86,20	50	19	92	50	61199	138,79
19	19	92	50	61253	56,83	35	19	92	50	61269	86,20	51	19	92	50	61284	156,85
20	19	92	50	61254	56,83	36	19	92	50	61270	98,41	52	19	92	50	61285	157,44
21	19	92	50	61255	59,61	37	19	92	50	61271	98,77	53	19	92	50	61286	157,44
22	19	92	50	61256	59,61	38	19	92	50	61272	98,77	54	19	92	50	61287	157,44
23	19	92	50	61257	59,61	39	19	92	50	61273	98,77	55	19	92	50	61288	157,44
24	19	92	50	61258	59,69	40	19	92	50	61274	98,77	56	19	92	50	61289	172,70
25	19	92	50	61259	59,69	41	19	92	50	61275	119,15	57	19	92	50	61290	172,70
26	19	92	50	61260	71,47	42	19	92	50	61276	119,15	58	19	92	50	61291	172,70
27	19	92	50	61261	71,47	43	19	92	50	61277	119,15	59	19	92	50	61292	183,06
28	19	92	50	61262	71,59	44	19	92	50	61278	119,15	60	19	92	50	61293	188,26
29	19	92	50	61263	71,59	45	19	92	50	61279	119,15						

Línea 33 cm
4067

FRESA HUECA MÁQUINAS ELECTROMAGNÉTICAS TCT LARGA

Long TCT Core Drill

Fraise à carotter pour unité de perçage electromagnetique TCT longue



ø	14	16	18	20	22
Pcs	2	2	2	2	2

Ref. 4995 - Nº Art. 72096: 573,89 €

Ref. **4075**

EXPULSORES

Pilot Pins

Ejecteurs



HSS

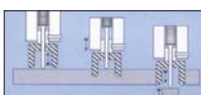

D mm	L mm	Cap. mm	Para/For/Pour Ref.	Nº Art.	€
6,34	106	12-17	4067 (50 mm)	61501	20,80
7,98	105	18-60	4067 (50 mm)	61503	24,96

Ref. **4060**

FRESA HUECA MÁQUINAS ELECTROMAGNÉTICAS HSS CORTA

Short HSS Core Drill

Fraise à carotter pour unité de perçage electromagnetique HSS courte

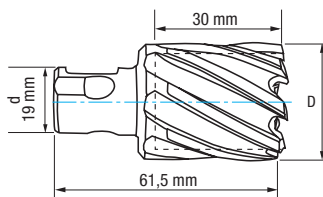

HSS

Serie Corta
Jobber Series
Série courte

Aceros Construcción
Structural Steels
Aciers de construction

Apto con Poca Lubricación
Suitable with Minimal Cooling
Apte avec lubrification minimale

UNIVERSAL:
NITTO +
WELDON

Aceros
<850 N/mm²
Steel / Aciers

Aceros
<1000 N/mm²
Steel / Aciers

Fundición
Cast Iron
Fonte

Aluminio
Aluminium



D mm	d mm	L mm	l mm	Nº Art.	€
12	19	61,5	30	61120	24,40
13	19	61,5	30	61121	24,40
14	19	61,5	30	61122	25,29
15	19	61,5	30	61123	26,35
16	19	61,5	30	61124	27,41
17	19	61,5	30	61125	28,28
18	19	61,5	30	61126	29,34
19	19	61,5	30	61127	30,06
20	19	61,5	30	61128	31,46
21	19	61,5	30	61129	33,59
22	19	61,5	30	61130	34,83
23	19	61,5	30	61131	36,25
24	19	61,5	30	61132	37,67
25	19	61,5	30	61133	38,90
26	19	61,5	30	61134	40,31
27	19	61,5	30	61135	40,66
28	19	61,5	30	61136	43,15
29	19	61,5	30	61137	44,57
30	19	61,5	30	61138	45,79
31	19	61,5	30	61139	49,86
32	19	61,5	30	61140	53,40
33	19	61,5	30	61141	56,23
34	19	61,5	30	61142	64,15
35	19	61,5	30	61143	71,00
36	19	61,5	30	61144	71,23

D mm	d mm	L mm	l mm	Nº Art.	€
37	19	61,5	30	61145	72,51
38	19	61,5	30	61146	73,23
39	19	61,5	30	61147	73,91
40	19	61,5	30	61148	74,19
41	19	61,5	30	61149	75,94
42	19	61,5	30	61150	80,97
43	19	61,5	30	61151	84,66
44	19	61,5	30	61152	87,36
45	19	61,5	30	61153	88,37
46	19	61,5	30	61154	90,35
47	19	61,5	30	61155	92,04
48	19	61,5	30	61156	95,75
49	19	61,5	30	61157	96,42
50	19	61,5	30	61158	102,12
51	19	61,5	30	61159	104,14
52	19	61,5	30	61160	107,50
53	19	61,5	30	61161	109,97
54	19	61,5	30	61162	115,50
55	19	61,5	30	61163	117,13
56	19	61,5	30	61164	121,02
57	19	61,5	30	61165	124,93
58	19	61,5	30	61166	126,89
59	19	61,5	30	61167	134,04
60	19	61,5	30	61168	141,90



Set 6 Pcs

Cont. Ø	Nº Art.	€
12-14-16-18-20-22	66860	172,72



Set 5 Pcs

Cont. Ø	Nº Art.	€
24-26-28-30-32	66861	220,30

Línea 33 cm
4060

FRESA HUECA MÁQUINAS ELECTROMAGNÉTICAS HSS CORTA

Short HSS Core Drill

Fraise à carotter pour unité de perçage electromagnetique HSS courte



ø	14	16	18	20	22
Pcs	2	2	2	2	2

Ref. 4995 - Nº Art. 72099: 296,64 €

Ref. **4075**

EXPULSORES

Pilot Pins

Ejecteurs



HSS

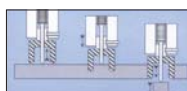

D mm	L mm	Para/For/Pour Ref.	Nº Art.	€
6,34	77	4060 (30 mm)	61502	8,86

Ref. **4061**

FRESA HUECA MÁQUINAS ELECTROMAGNÉTICAS HSS LARGA

Long HSS Core Drill

Fraise à carotter pour unité de perçage electromagnetique HSS longue

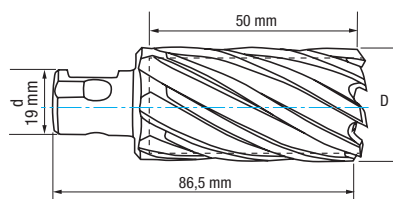

HSS

Serie Larga
Long Length
Série longue

Aceros Construcción
Structural Steels
Aciers de construction

Apto con Poca Lubricación
Suitable with Minimal Cooling
Apte avec lubrification minimale

Rectificado
Ground
Taillé meulé

UNIVERSAL:
NITTO +
WELDON



Aceros
<850 N/mm²
Steel / Aciers

Aceros
<1000 N/mm²
Steel / Aciers

Fundición
Cast Iron
Fonte

Aluminio
Aluminium

D mm	d mm	L mm	l mm	Nº Art.	€	D mm	d mm	L mm	l mm	Nº Art.	€	D mm	d mm	L mm	l mm	Nº Art.	€
12	19	86,5	50	73340	33,79	28	19	86,5	50	61183	64,36	45	19	86,5	50	61201	110,50
13	19	86,5	50	73342	33,79	29	19	86,5	50	61184	66,82	46	19	86,5	50	61202	111,82
14	19	86,5	50	61169	35,03	30	19	86,5	50	61185	67,59	47	19	86,5	50	61203	118,07
15	19	86,5	50	61170	36,43	31	19	86,5	50	61186	71,00	48	19	86,5	50	61204	121,02
16	19	86,5	50	61171	38,90	32	19	86,5	50	61187	74,10	49	19	86,5	50	61205	121,68
17	19	86,5	50	61172	40,31	33	19	86,5	50	61188	77,54	50	19	86,5	50	61206	124,31
18	19	86,5	50	61173	43,33	34	19	86,5	50	61189	80,96	51	19	86,5	50	61207	131,55
19	19	86,5	50	61174	44,20	35	19	86,5	50	61190	84,39	52	19	86,5	50	61208	136,81
20	19	86,5	50	61175	45,45	36	19	86,5	50	61191	86,79	53	19	86,5	50	61209	153,24
21	19	86,5	50	61176	50,57	37	19	86,5	50	61192	90,05	54	19	86,5	50	61210	155,51
22	19	86,5	50	61177	51,99	38	19	86,5	50	61193	92,62	55	19	86,5	50	61211	157,00
23	19	86,5	50	61178	53,75	39	19	86,5	50	61194	95,37	56	19	86,5	50	61212	161,70
24	19	86,5	50	61179	55,35	40	19	86,5	50	61195	100,31	57	19	86,5	50	61213	171,80
25	19	86,5	50	61180	56,93	41	19	86,5	50	61196	101,95	58	19	86,5	50	61214	171,84
26	19	86,5	50	61181	58,71	42	19	86,5	50	61197	103,27	59	19	86,5	50	61215	181,60
27	19	86,5	50	61182	61,53	43	19	86,5	50	61198	105,91	60	19	86,5	50	61216	188,24
						44	19	86,5	50	61200	107,22						

Línea 33 cm
4061

FRESA HUECA MÁQUINAS ELECTROMAGNÉTICAS HSS LARGA

Long HSS Core Drill

Fraise à carotter pour unité de perçage electromagnetique HSS longue



∅	14	16	18	20	22
Pcs	2	2	2	2	2

Ref. 4995 - Nº Art. 72105: 429,39 €

Ref. **4075**

EXPULSORES

Pilot Pins

Ejecteurs



HSS

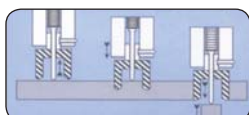

D mm	L mm	Para/For/Pour Ref.	Nº Art.	€
6,34	102	4061 (50 mm)	61500	12,23

Ref. **4062**

FRESA HUECA MÁQUINAS ELECTROMAGNÉTICAS HSS EXTRA LARGA

Extra Long HSS Core Drill

Fraise à carotter pour unité de perçage electromagnetique HSS extra-longue

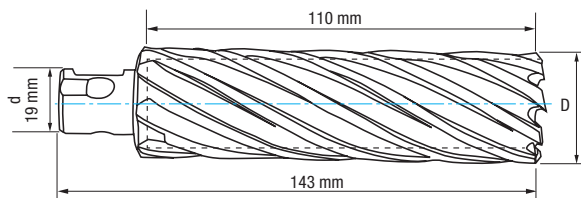

HSS

Serie Extra-Larga
Extra-Long Series
Série extra-longue

Aceros Construcción
Structural Steels
Aciers de construction

Apto con Poca Lubricación
Suitable with Minimal Cooling
Apte avec lubrification minimale

UNIVERSAL:
NITTO +
WELDON

Aceros
<850 N/mm²
Steel / Aciers

Aceros
<1000 N/mm²
Steel / Aciers

Fundición
Cast Iron
Fonte

Aluminio
Aluminium



D mm	d mm	L mm	l mm	Nº Art.	€	D mm	d mm	L mm	l mm	Nº Art.	€	D mm	d mm	L mm	l mm	Nº Art.	€		
20	19	143	110	61217	90,73	31	19	143	110	61228	128,68	42	19	143	110	61239	190,27		
21	19	143	110	61218	92,44	32	19	143	110	61229	130,95	43	19	143	110	61240	193,48		
22	19	143	110	61219	94,19	33	19	143	110	61230	140,22	44	19	143	110	61241	196,76		
23	19	143	110	61220	96,06	34	19	143	110	61231	142,75	45	19	143	110	61242	237,18		
24	19	143	110	61221	101,77	35	19	143	110	61232	145,37	46	19	143	110	61243	240,40		
25	19	143	110	61222	103,64	36	19	143	110	61233	148,06	47	19	143	110	61244	243,77		
26	19	143	110	61223	114,43	37	19	143	110	61234	151,13	48	19	143	110	61245	247,04		
27	19	143	110	61224	116,51	38	19	143	110	61235	153,97	49	19	143	110	61246	250,40		
28	19	143	110	61225	118,80	39	19	143	110	61236	156,88	50	19	143	110	61247	253,81		
29	19	143	110	61226	121,03	40	19	143	110	61237	159,87								
30	19	143	110	61227	123,34	41	19	143	110	61238	187,14								

Línea 33 cm
4062

FRESA HUECA MÁQUINAS ELECTROMAGNÉTICAS HSS EXTRA LARGA

Extra Long HSS Core Drill

Fraise à carotter pour unité de perçage electromagnetique HSS extra-longue



ø	20	22	26	32	40
Pcs	1	1	1	1	1

Ref. 4995 - Nº Art. 72108: 590,17 €

Ref. **4075**

EXPULSORES

Pilot Pins

Ejecteurs



HSS

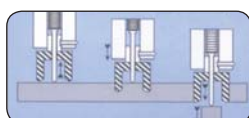

D mm	L mm	Para/For/Pour Ref.	Nº Art.	€
7,98	154	4062 (110 mm)	61504	21,65

CORONAS

Hole Saws

Trépan

Ref. **1667**

CORONA REAFILABLE HSS

HSS Resharpenable Hole Saw
Fraise réaffûtable HSS

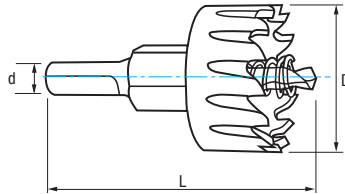

Aceros
<850 N/mm²
Steel / Aciers

Fundición
Cast Iron
Fonte

Cobre
Copper
Cuivre

Latón
Brass
Laiton

Aluminio
Aluminium

Madera
Wood
Bois

D mm	d mm	L mm	D mm Broca Drill Bit Foret	Nº Art.	€
12	10	75,50	6	56569	16,34
13	10	75,50	6	56570	16,34
14	10	75,50	6	56572	16,34
15	10	75,50	6	56573	16,34
16	10	75,50	6	56152	16,34
17	10	75,50	6	56576	17,53
18	10	75,50	6	56578	18,80
19	10	75,50	6	56579	19,89
20	10	75,50	6	56154	20,98
21	10	75,50	6	56582	20,98
22	10	75,50	6	56155	22,07
23	10	75,50	6	56583	23,15
24	10	75,50	6	56584	24,38
25	10	75,50	6	56156	25,47
26	10	75,50	6	56585	26,56
27	10	75,50	6	56157	27,65
28	10	75,50	6	56587	29,11
29	10	75,50	6	56588	30,20
30	10	75,50	6	56158	30,20
32	10	75,50	6	56159	32,39

D mm	d mm	L mm	D mm Broca Drill Bit Foret	Nº Art.	€
33	10	75,50	6	56590	33,47
35	10	75,50	6	56160	34,57
36	10	75,50	6	56591	36,74
38	10	75,50	6	56593	38,45
39	10	75,50	6	56594	39,55
40	10	75,50	6	56161	40,64
42	10	75,50	6	56596	42,75
45	10	75,50	6	56597	46,06
48	10	75,50	6	56163	48,37
49	10	75,50	6	68602	50,19
50	10	75,50	6	56164	50,56
51	10	75,50	6	68604	61,59
53	10	75,50	6	56599	61,59
55	10	75,50	6	56600	62,82
60	10	75,50	6	56165	68,96
63	10	75,50	6	68605	83,69
65	10	75,50	6	56602	83,69
68	10	75,50	6	68607	96,59
70	10	75,50	6	56166	96,59
75	10	75,50	6	56167	103,96

D mm	d mm	L mm	D mm Broca Drill Bit Foret	Nº Art.	€
76	10	75,50	6	68608	121,09
80	10	75,50	6	56603	121,09
85	10	75,50	6	56605	127,61
90	10	75,50	6	56606	141,11
100	10	75,50	6	56608	154,60



Set 6 Pcs

Cont. Ø	Nº Art.	€
12-14-16-18-20-22	77448	110,86

TIN

Bajo demanda / upon request / sur demande

Ref. **1664**



Broca / Drill Bit / Foret

D mm	L mm	Nº Art.	€ 1 ud.
6	48	60704	3,70



Muelle / Spring / Ressort

D mm	L mm	Nº Art.	€ pack
8,5	20	60637	0,85
8,5	35	60638	0,87

Expo
1667

EXPOSITOR CORONAS REAFILABLES HSS

HSS Resharpenable Hole Saw Exhibitor
Présentoir fraises réaffûtables HSS

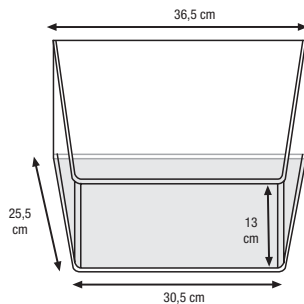

31 Pcs

Nº Art.	€
66804	945,88

Diam.	Nº Art.	Uds.	Diam.	Nº Art.	Uds.
12	56569	1	28	56587	1
13	56570	1	29	56588	1
14	56572	1	30	56158	1
15	56573	1	32	56159	1
16	56152	1	33	56590	1
17	56576	1	35	56160	1
18	56578	1	36	56591	1
19	56579	1	38	56593	1
20	56154	1	39	56594	1
21	56582	1	40	56161	1
22	56155	1	42	56596	1
23	56583	1	45	56597	1
24	56584	1	48	56163	1
25	56156	1	50	56164	1
26	56585	1	65	56602	1
27	56157	1			

Línea 1m
1667

CORONA REAFILABLE HSS

HSS Resharpenable Hole Saw
Fraise réaffûtable HSS



ø	16	19	20	22	24	25	27	29	30	32	35	51	63	65
Pcs	1	1	1	1	1	1	1	1	1	1	1	1	1	1

Ref. 4995 - Nº Art. 72109: 513,09 €

Display
65

CORONA REAFILABLE HSS

HSS Resharpenable Hole Saw
Fraise réaffûtables HSS



ø	16	18	20	22	24	25	27	32
Pcs	1	1	1	1	1	1	1	1

Ref. 4995 - Nº Art. 70083: 188,07 €

Ref. **1663**

CORONA INOX ALTO RENDIMIENTO

TCT High Performance STAINLESS Hole Saw
Trépan INOX haut rendement

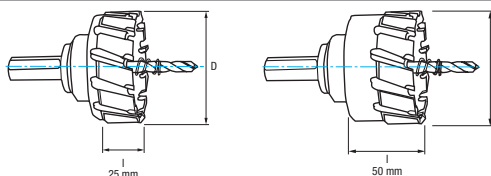

Husillo incluido
Included Spindle
Arbre compris

Broca incluida
Included Center Drill
Foret compris

Cono Morse opcional
Optional Morse Taper
Cône Morse optionel

Diente MD
Carbide Tipped
Dent carbure

PVC

Fibra Vidrio
Fiberglass
Fibre de verre

Aceros
<850 N/mm²
Steel / Aciers

Plásticos
Plastics
Plastiques

INOX
Stainless Steel
Acier INOX

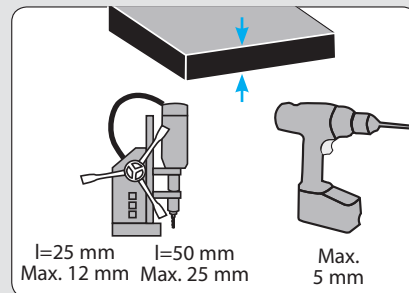
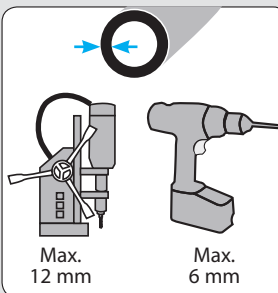

D mm	l mm	d mm	Nº Art.	€
14	25	13	71756	74,25
15	25	13	71758	74,25
16	25	13	71760	74,25
17	25	13	71761	74,25
18	25	13	71762	74,53
19	25	13	71763	74,25
20	25	13	71764	75,66
21	25	13	71765	78,10
22	25	13	71768	78,10
23	25	13	71769	79,23
24	25	13	71770	79,23
25	25	13	71771	79,23
26	25	13	71772	80,52
27	25	13	71773	81,83
28	25	13	71774	81,83
29	25	13	71775	81,83
30	25	13	71776	81,83
31	25	13	71777	92,41
32	25	13	71780	95,73
33	25	13	71781	95,73
34	25	13	71782	96,77
35	25	13	71783	96,77
36	25	13	71784	108,42
37	25	13	71785	108,42

D mm	l mm	d mm	Nº Art.	€
38	25	13	71787	111,13
39	25	13	71788	111,13
40	25	13	71789	112,29
41	25	13	71790	122,13
42	25	13	71791	133,02
43	25	13	71792	133,02
44	25	13	71793	133,02
45	25	13	71794	136,79
46	25	13	71795	139,31
47	25	13	71796	139,31
48	25	13	71797	139,31
49	25	13	71798	139,31
50	25	13	71799	141,51
51	25	13	71800	164,83
52	25	13	71801	164,83
53	25	13	71802	166,00
54	25	13	71803	166,00
55	25	13	71804	166,00
56	25	13	71805	184,37
57	25	13	71806	184,37
58	25	13	71807	184,37
59	25	13	71808	184,37
60	25	13	71809	184,37

D mm	l mm	d mm	Nº Art.	€
18	50	13	71952	85,70
20	50	13	71953	87,02
22	50	13	71955	89,82
25	50	13	71956	91,11
30	50	13	71957	94,11
35	50	13	71958	106,46
40	50	13	71959	123,51
45	50	13	71960	150,48
50	50	13	71961	155,67
55	50	13	71962	182,59
60	50	13	71963	202,81
65	50	13	71810	217,46
68	50	13	71964	234,69
70	50	13	71811	234,69
75	50	13	71812	237,80
80	50	13	71814	246,16
85	50	13	71815	255,03
90	50	13	71817	261,19
95	50	13	71818	261,66
100	50	13	71819	265,19
105	50	13	71965	279,80
110	50	13	71966	310,76
115	50	13	71967	344,45
120	50	13	71968	381,20
125	50	13	71970	407,80

Ref. **1659**

ACCESORIOS / Accessories / Accessoires

Broca Centrar *
Center Drill / Foret à centrer



Para Corona	Cap.	D	L	l	Nº	€
For Hole Saw	mm	mm	mm	mm	Art.	
Pour Trépan						
l mm						
25	14-60	6	80	30	71982	12,43
25	61-125	8	80	30	71983	13,63
50	14-60	6	110	55	71985	17,98
50	61-125	8	110	55	71986	21,97

Husillo 3 Planos *
3-Flat Spindle / Arbre 3 plans



Cap.	L	Nº	€
mm	mm	Art.	
14-60	53	71977	19,55
61-100	53	71979	19,55
101-125	57	71980	31,39

Cono Morse **
Morse Taper / Cône Morse



CM	Cap.	L	Nº	€
	mm	mm	Art.	
2	16-100	108,5	71988	59,27
3	101-125	133	71989	78,75

* Repuesto incluido / Included Spare / Rechange compris

** Accesorio opcional / Optional Accessory / Accessoire optionel

Ref. **1665**

CORONA INOX
TCT STAINLESS Hole Saw
Trépan INOX

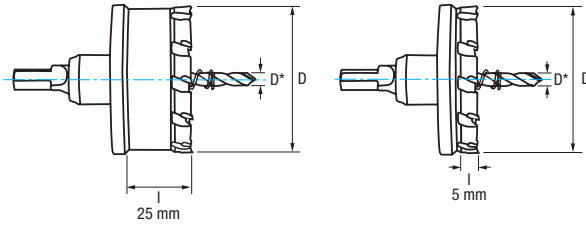

Diente MD
Carbide Tipped
Dent carbure

PVC

Fibra Vidrio
Fiberglass
Fibre de verre

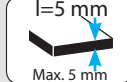
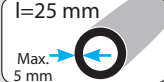

Aceros
<850 N/mm²
Steel / Aciers

INOX
Stainless Steel
Acier INOX

Plásticos
Plastics
Plastiques

D mm	l mm	Pulgadas Inches Pouces	D* mm Broca Drill Bit Foret	Nº Art.	€
16	25	5/8	6	60642	57,12
17	25	11/16	6	60643	57,12
18	25	23/32	6	13796	57,33
19	25	3/4	6	60645	57,12
20	25	25/32	6	13798	58,21
21	25	13/16	6	13799	60,09
22	25	7/8	6	13800	60,09
23	25	14/16	6	13801	60,94
24	25	15/16	6	13802	60,94
25	25	1	6	13803	60,94
26	25	1 1/32	6	13804	64,41
27	25	1 1/16	6	13805	65,46
28	25	1 3/32	6	13806	65,46
29	25	1 1/8	6	13807	65,46
30	25	1 3/16	6	13808	65,46
31	25	1 7/32	6	13809	77,02
32	25	1 1/4	6	13810	79,77
33	25	1 5/16	6	13811	79,77
34	25	1 11/32	6	13812	80,64
35	25	1 3/8	6	13813	80,64
36	25	1 13/32	6	60646	90,36
37	25	1 7/16	6	60647	90,36
38	25	1 1/2	6	13816	92,61
39	25	1 17/32	6	60648	92,61
40	25	1 9/16	6	13818	93,57
41	25	1 5/8	6	60649	101,78
42	25	1 21/32	6	13820	110,85
43	25	1 11/16	6	60652	110,85
44	25	1 3/4	6	60650	110,85
45	25	1 25/32	6	13823	114,00
50	25		6	13828	117,93
52	25	2 1/16	6	13830	137,36
53	25	2 3/32	6	13831	138,33
55	25		6	13833	138,33
60	25	2 3/8	6	13838	153,64
63	25		6	13841	193,61
65	25	2 9/16	6	60651	193,61
70	25	2 3/4	6	60653	193,85
75	25		6	60654	201,86
80	25		6	60655	212,08
85	25		6	60656	231,96
90	25		6	60657	249,18
95	25	3 3/4	6	60658	268,77
100	25	3 15/16	6	60659	286,15

D mm	l mm	Pulgadas Inches Pouces	D* mm Broca Drill Bit Foret	Nº Art.	€
14	5	9/16	6	60660	38,36
16	5	5/8	6	60661	38,36
18	5	23/32	6	60662	38,36
20	5	25/32	6	60663	38,36
22	5	7/8	6	60664	43,09
25	5	1	6	60666	43,09
30	5	1 3/16	6	60667	45,83
32	5	1 1/4	6	60668	51,43
35	5	1 3/8	6	60669	51,43
40	5	1 9/16	6	60670	57,05
45	5	1 25/32	6	60671	62,80
50	5		6	60672	68,01
60	5	2 3/8	6	60673	82,01

Ref. **1664**



Broca / Drill Bit / Foret

D mm	L mm	Nº Art.	€ 1 ud.
6	48	60704	3,70
6	76	60636	4,14

Muelle / Spring / Ressort

D mm	L mm	Nº Art.	€ pack
8,5	20	10 60637	0,85
8,5	35	10 60638	0,87

Display 66

CORONAS INOX
TCT STAINLESS Hole Saws
Trépan INOX



19 cm

∅	16	18	20	22	24	25	27	32
Pcs	1	1	1	1	1	1	1	1

Ref. 4995 - Nº Art. 71094: 499,86 €

Ref. **1636**

PERFORADOR DE CHAPA

Screw Hole Punch
Perforateur de tôle

New!



HSS

Chapa
Sheets
Tôle

Aceros
<850 N/mm²
Steel / Aciers

INOX
Stainless Steel
Acier INOX

D mm	D mm Broca Drill Bit - Foret	Nº Art.	€
32,50	12,00	13671	46,03
35,00	12,00	13676	46,03

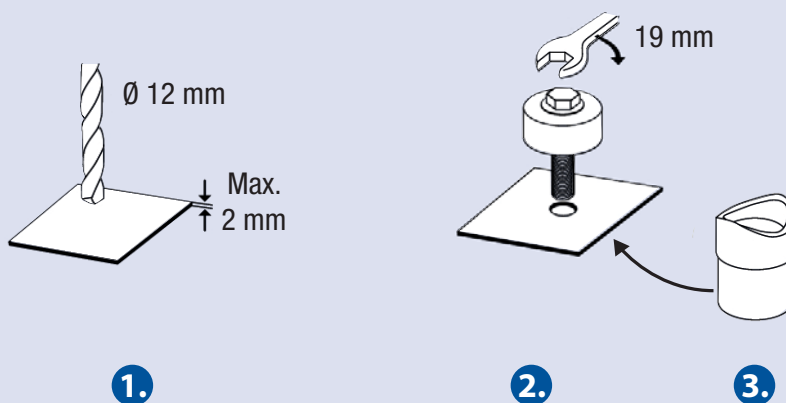

INSTRUCCIONES USO:

1. Taladrar un agujero previo con la broca
2. Introducir el tornillo por el agujero y por el lado contrario enroscar la cuchilla
3. Aplicar un par de apriete hasta seccionar la chapa

DIRECTIONS FOR USE:

1. Drill a pilot hole with the drill bit
2. Insert the screw through the hole and, on the opposite side, screw the blade
3. Apply a tightening torque until the sheet is divided

INSTRUCTIONS D'EMPLOI:

1. Percez un trou de guidage avec le foret
2. Insérez la vis dans le trou et, du côté opposé, vissez la lame
3. Appliquez un couple de serrage jusqu'à ce que la tôle soit divisée



Ref. **2015**

ESCARIADOR MANO EXTENSIBLE REFORZADO

Reinforced Rapidly Adjustable Hand Reamer
Alésoir à lames réglables renforcée



HSS

Aceros
<850 N/mm²
Steel / Aciers

Aluminio
Aluminium



Cap. mm	L mm	I mm	Z	Nº Art.	€
06,40-07,20	85	34	4	21076	89,62
07,20-08,00	90	35	4	21077	89,62
08,00-09,00	100	39	5	21079	89,62
09,00-10,00	120	45	5	21080	89,62
10,00-11,00	125	45	5	21081	89,62
11,00-12,00	130	46	5	21082	89,62
12,00-13,50	135	48	5	21084	89,62
13,50-15,50	140	58	5	21085	89,62
15,50-18,00	165	69	5	21086	95,36
18,00-21,00	185	75	5	21087	98,71

Cap. mm	L mm	I mm	Z	Nº Art.	€
21,00-24,00	195	80	5	21088	114,84
24,00-27,50	215	90	6	21089	125,03
27,50-31,50	240	100	6	21090	136,71
31,50-37,00	265	110	6	21091	178,23
37,00-45,00	310	130	6	21092	265,77
45,00-55,00	380	145	6	21093	382,34
55,00-67,00	152	440	6	21094	549,98

Ref. **2016**

ESCARIADOR MANO EXTENSIBLE CON GUÍA

Guided Rapidly Adjustable Hand Reamer
Alésoir à lames réglables avec guide



HSS

Aceros
<850 N/mm²
Steel / Aciers

Aluminio
Aluminium



Cap. mm	L mm	I mm	Z	Nº Art.	€
08,00-09,00	175	39	5	21346	104,65
09,00-10,00	185	39	5	21347	104,65
10,00-11,00	195	45	5	21348	104,65
11,00-12,00	200	45	5	21350	104,65
12,00-13,50	220	48	5	21351	106,74
13,50-15,50	243	58	5	21352	111,01
15,50-18,00	274	69	5	21353	116,24
18,00-21,00	300	75	5	21354	123,61

Cap. mm	L mm	I mm	Z	Nº Art.	€
21,00-24,00	320	80	6	21355	141,39
24,00-27,50	350	90	6	21356	158,22
27,50-31,50	385	100	6	21357	178,15
31,50-37,00	424	110	6	21358	245,49
37,00-45,00	490	130	6	21360	343,77
45,00-55,00	600	145	6	21363	492,74

Ref. **2017**

CUCHILLA ESCARIADOR MANO EXTENSIBLE

Adjustable Hand Reamer Blade
Lame pour alésoir réglable à main



HSS

Aceros
<850 N/mm²
Steel / Aciers

Aluminio
Aluminium

Cap. mm	L mm	C	Nº Art.	€ pack
06,40-07,20	34,00	4	49927	44,90
07,20-08,00	35,00	4	49928	44,90
08,00-09,00	39,00	5	49929	44,90
09,00-10,00	44,50	5	49930	44,90
10,00-11,00	45,00	5	49931	44,90
11,00-12,00	46,50	5	49932	44,90
12,00-13,50	48,00	5	26516	44,90
13,50-15,50	54,00	5	49933	44,90
15,50-18,00	69,00	5	43410	47,02

Cap. mm	L mm	C	Nº Art.	€ pack
18,00-21,00	75,00	5	19594	49,55
21,00-24,00	80,00	5	49934	56,90
24,00-27,50	90,00	6	22499	60,04
27,50-31,50	100,00	6	22500	66,07
31,50-37,00	110,00	6	49935	81,26
37,00-45,00	130,00	6	28820	125,77
45,00-55,00	145,00	6	49936	193,43
55,00-67,00	174,00	6	51333	304,84

AVELLANADORES

Countersinks / Counterbores

Outils

Ref. **2575**

AVELLANADOR MANGO CILÍNDRICO 90°

90° Straight Shank Countersink

Fraise à noyer 90°

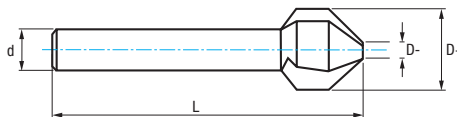

HSSE
5% Co

DIN
335 C



3 Z

Tol. D
(±0,05)

Tol. d
(h9)

Tol. L
(± 1)

Tol. ∞
0
1

Aceros
<850 N/mm²
Steel / Aciers

INOX
Stainless Steel
Acier INOX

Cobre
Copper
Cuivre

Aluminio
Aluminium

Termoplásticos
Thermoplastics
Thermoplastiques



D+ mm	D- mm	d mm	L mm	Nº Art.	€
4,30	1,30	4,00	40	74653	12,73
5,00	1,50	4,00	40	74654	12,34
5,30	1,50	4,00	40	74655	12,62
5,80	1,50	5,00	45	74656	12,91
6,00	1,50	5,00	45	74657	12,91
6,30	1,50	5,00	45	74658	12,46
7,00	1,80	6,00	50	74659	12,60
7,30	1,80	6,00	50	74660	12,77
8,00	2,00	6,00	50	74661	13,48
8,30	2,00	6,00	50	74662	13,62
9,40	2,20	6,00	50	74663	14,21
10,00	2,50	6,00	50	74664	14,91
10,40	2,50	6,00	50	74665	17,76
11,50	2,80	8,00	56	74666	16,50
12,40	2,80	8,00	56	74667	17,06
13,40	2,90	8,00	56	74668	18,64
15,00	3,20	10,00	60	74669	21,07
16,50	3,20	10,00	60	74670	24,18
19,00	3,50	10,00	63	74671	31,53
20,50	3,50	10,00	63	74672	32,26
23,00	3,80	10,00	67	74673	39,43
25,00	3,80	10,00	67	74674	42,31
28,00	4,00	12,00	71	42714	59,26
30,00	4,20	12,00	71	12588	63,40
31,00	4,20	12,00	71	42715	63,40
40,00	5,00	15,00	80	11061	115,29



Set 6 Pcs

Cont. Ø	Nº Art.	€
6,3-8,3-10,4-12,4-16,5-20,5	40515	117,33

TIN bajo demanda / upon request / sur demande

Línea 33 cm
2575

AVELLANADOR MANGO CILÍNDRICO 90°

90° Straight Shank Countersink

Fraise à noyer 90°



Ø	5	6	7	10	12,4	15
Pcs	2	2	2	2	2	2

Ref. 4995 - Nº Art. 70987: 181,76 €

Ref. **2530**

AVELLANADOR MANGO CILÍNDRICO ALLEN

Allen Straight Shank Counterbor
Fraise à lamer et chambrer

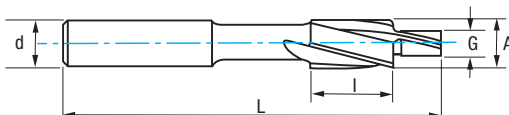

HSS	DIN 373	ISO 4206	Allen		Tol. A z9	Tol. G e8	Tol. d h9	Aluminio Aluminium >10% Si
Aceros <850 N/mm ² Steel / Aciers	Aceros <1000 N/mm ² Steel / Aciers	INOX Ferríticos-Martensíticos Ferritic-Martensitic Stainless INOX Ferritiques-Martensitiques	Fundición Cast Iron Fonte	Titanio Titanium Titane	Cobre Copper Cuivre			



M	A mm	G mm	d mm	L mm	I mm	Z	Nº Art.	€
M3	6,50	3,40	5,00	71	14	3	42029	19,02
M4	8,00	4,50	5,00	71	14	3	42032	19,02
M5	10,00	5,50	8,00	80	18	3	42035	19,02
M6	11,00	6,60	8,00	80	18	3	42038	21,43
M8	15,00	9,00	12,50	100	22	3	42041	26,53
M10	18,00	11,00	12,50	100	22	3	42044	31,58
M12	20,00	13,50	12,50	100	22	3	42047	37,38
M14	24,00	15,50	16,00	100	22	4	42050	55,87
M16	26,00	17,50	16,00	100	22	4	42053	61,77



Set 6 Pcs

Cont.	Nº Art.	€
M3-M4-M5-M6-M8-M10	40512	136,61

Línea 33 cm
2530

AVELLANADOR MANGO CILÍNDRICO ALLEN

Allen Straight Shank Counterbor
Fraise à lamer et chambrer



ø	M5	M6	M8	M10	M12
Pcs	1	1	1	1	1

Ref. 4995 - Nº Art. 72112: 135,95 €

Ref. **2572**

AVELLANADOR MANGO CILÍNDRICO 90°

90° Straight Shank Counterbor
Fraise à ebavurer 90°

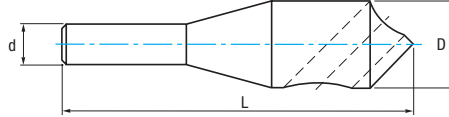

HSSE
5% Co

IZAR
Std.



Tol.
+0
D +0,3

Tol.
d (h9)

Tol.
L (± 1)

Tol. ∞
0
1

Aceros
<850 N/mm²
Steel / Aciers

INOX Ferríticos-Martensíticos
Ferritic-Martensitic Stainless
INOX Ferritiques-Martensitiques

Aluminio
Aluminium



Aplic. mm	D mm	d mm	L mm	Nº Art.	€
2-5	10,00	6,00	46	69183	22,16
5-10	14,00	8,00	55	69181	29,91
10-15	20,00	10,00	65	69184	55,33
15-20	28,00	12,00	85	69187	105,22
20-25	30,00	15,00	95	69186	149,53



Set 4 Pcs

Aplic. mm	Nº Art.	€
2-5, 5-10, 10-15, 15-20	40513	212,62

Línea 33 cm
2572

AVELLANADOR MANGO CILÍNDRICO 90°

90° Straight Shank Counterbor
Fraise à ebavurer 90°



∅	2-5	5-10	10-15	15-20	20-25
Pcs	1	1	1	1	1

Ref. 4995 - Nº Art. 72115: 362,15 €

MACHOS Y COJINETES

Taps & Dies
Tarauds et Filières

Ref. **3030**

JUEGO MACHOS MANO MÉTRICA

Metric Hand Tap Set
Jeu de tarauds à main métrique

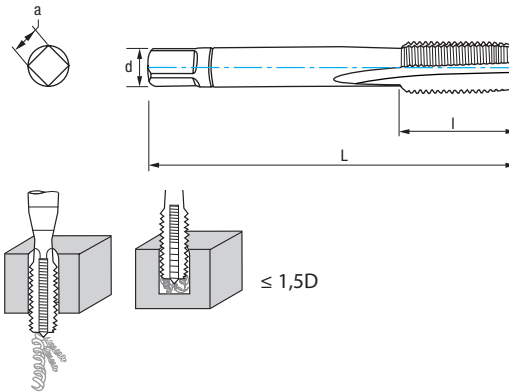

Aceros
<math><850 \text{ N/mm}^2</math>
Steel / Aciers

Fundición
Cast Iron
Fonte

Cobre
Copper
Cuivre

Aluminio
Aluminium



M	P	L mm	l mm	d mm	a mm	Z	Nº Art.	€	M	P	L mm	l mm	d mm	a mm	Z	Nº Art.	€
M2	0,40	36	8	2,80	2,10	3	62531	26,72	M15	2,00	80	32	12,00	9,00	4	62588	74,78
M2,5	0,45	40	9	2,80	2,10	3	62534	26,72	M16	2,00	80	32	12,00	9,00	4	62591	53,08
M3	0,50	40	11	3,50	2,70	3	62537	15,12	M18	2,50	95	34	14,00	11,00	4	62594	70,34
M3,5	0,60	45	13	4,00	3,00	3	62540	17,81	M20	2,50	95	34	16,00	12,00	4	62597	79,25
M4	0,70	45	13	4,50	3,40	3	62543	15,12	M22	2,50	100	34	18,00	14,50	4	62603	105,97
M4	0,75	45	14	4,50	3,40	3	76377	26,18	M24	3,00	110	38	18,00	14,50	4	62606	124,19
M4,5	0,75	50	16	6,00	4,90	3	62546	26,72	M27	3,00	110	38	20,00	16,00	4	62609	159,82
M5	0,80	50	16	6,00	4,90	3	62549	16,03	M30	3,50	125	45	22,00	18,00	4	62612	204,76
M6	1,00	56	19	6,00	4,90	3	62552	16,03	M33	3,50	125	50	25,00	20,00	4	62615	258,20
M7	1,00	56	19	6,00	4,90	3	62555	19,59	M36	4,00	150	56	28,00	22,00	4	62618	329,40
M8	1,25	56	22	6,00	4,90	4	62561	19,59	M39	4,00	150	60	32,00	24,00	4	62621	368,62
M9	1,25	63	22	7,00	5,50	4	62567	32,05	M42	4,50	150	60	32,00	24,00	4	62624	461,20
M10	1,50	70	24	7,00	5,50	4	62573	24,06	M45	4,50	160	65	36,00	29,00	6	73760	532,43
M11	1,50	70	24	8,00	6,20	4	62576	40,06	M48	5,00	180	70	36,00	29,00	6	62627	641,04
M12	1,75	75	28	9,00	7,00	4	62579	33,82	M52	5,00	180	70	40,00	32,00	6	76382	778,17
M13	1,75	75	28	9,00	7,00	4	62582	61,42	M56	5,50	180	70	40,00	32,00	6	76383	1.200,04
M14	2,00	80	30	11,00	9,00	4	62585	37,41	M60	5,50	200	85	45,00	35,00	6	76384	1.501,94

Macho único Ref. 3010 disponible en [pag. 128](#)

Single Tap Ref. 3010 available in [page 128](#)

Taraud unique Ref. 3010 disponible [pag. 128](#)

Ref. **3003**

JUEGO MACHOS MANO MÉTRICA

Metric Hand Tap Set
Jeu de tarauds à main métrique

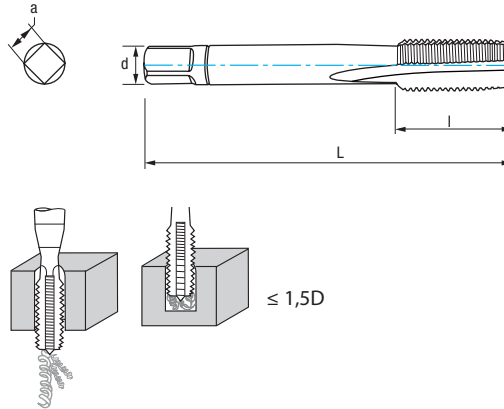

Aceros
<math><850 \text{ N/mm}^2</math>
Steel / Aciers

Fundición
Cast Iron
Fonte

Cobre
Copper
Cuivre

Aluminio
Aluminium



M	P	L mm	l mm	d mm	a mm	Z	Nº Art.	€
M3	0,50	40	11	3,50	2,70	3	42876	15,42
M4	0,70	45	13	4,50	3,40	3	42879	15,42
M5	0,80	50	16	6,00	4,90	3	42882	16,34
M6	1,00	56	19	6,00	4,90	3	42884	16,34
M7	1,00	56	19	6,00	4,90	3	42885	19,97
M8	1,25	63	22	6,00	4,90	4	42886	19,97
M10	1,50	70	24	7,00	5,50	4	42887	24,53
M12	1,75	75	28	9,00	7,00	3	42888	34,48
M14	2,00	80	30	11,00	9,00	4	42889	38,13
M16	2,00	80	32	12,00	9,00	4	42890	54,11
M18	2,50	95	34	14,00	11,00	4	42891	71,71
M20	2,50	95	34	16,00	12,00	4	42892	80,78

Macho único Ref. 3001 disponible en [pag. 130](#)

Single Tap Ref. 3001 available in [page 130](#)

Taraud unique Ref. 3001 disponible [pag. 130](#)

Línea 33 cm
3003

JUEGO MACHOS MANO MÉTRICA

Metric Hand Tap Set
Jeu de tarauds à main métrique



ø	M3	M5	M6	M10	M12
Pcs	3	3	3	3	3

Ref. 4995 - Nº Art. 70990: 321,31 €

Display 22



JUEGO MACHOS MANO MÉTRICA

Metric Hand Tap Set

Jeu de tarauds à main métrique

∅	M20	Mod. 01	Mod. 02	Mod. 10	Mod. 20		
Pcs	1	1	1	1	1		
∅	M12	M14	M16	M18			
Pcs	2	1	1	1			
∅	M-3	M-4	M-5	M-6	M-7	M-8	M10
Pcs	2	2	2	2	2	2	2

Ref. 4995 - N° Art. 22298: **692,44 €**

Display 44



26
cm

JUEGO MACHOS MANO MÉTRICA

Metric Hand Tap Set

Jeu de tarauds à main métrique

∅	M-4	M-5	M-6	M-8	M-10	01
Pcs	2	2	2	2	2	2

Ref. 4995 - N° Art. 42490: **227,40 €**

Ref. **3036**

JUEGO MACHOS MANO MÉTRICA COBALTO INOX

STAINLESS Cobalt Metric Hand Tap Set

Jeu de tarauds à main métrique Cobalt INOX

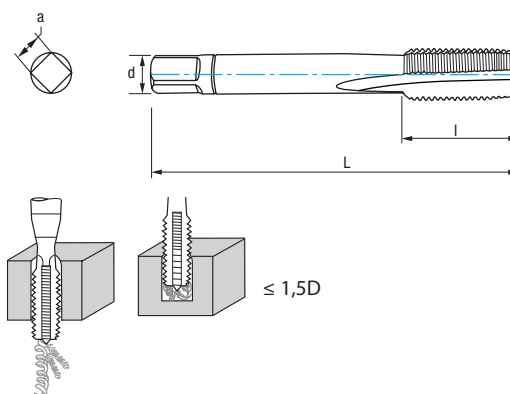

HSSE
5% Co

M
DIN
352

MF
DIN
2181

Tol.
6H

Vaporiz.

C
2-3h

α
6-8°



Grupo
Group-Grpue
P

Subgrup.
P.5

INOX
Stainless Steel
Acier INOX

Fundición
Cast Iron
Fonte

Nº1 Desbaste
Roughing
Ébauche

Nº2 Semidesbaste
Semiroughing
Semi-ébauche

Nº3 Acabado
Finishing
Finition

Nº1-Nº2 Con guía
Guided
Avec guide

M	P	L mm	l mm	d mm	a mm	Z	Nº Art.	€
M2	0,40	36	8	2,80	2,10	3	69229	34,94
M3	0,50	40	11	3,50	2,70	3	16404	27,95
M4	0,70	45	13	4,50	3,40	3	16405	27,95
M5	0,80	50	16	6,00	4,90	3	16406	29,10
MF6	0,75	56	14	6,00	4,90	3	82254	54,09
M6	1,00	56	19	6,00	4,90	3	16407	29,10
MF8	1,00	63	18	6,00	4,90	3	82255	54,09
M8	1,25	63	22	6,00	4,90	3	16408	33,80
MF10	1,00	63	18	7,00	5,50	3	82256	60,06
M10	1,50	70	24	7,00	5,50	3	16409	43,47
MF12	1,00	70	18	9,00	7,00	3	82257	68,59
MF12	1,50	70	22	9,00	7,00	3	82258	67,01
M12	1,75	75	29	9,00	7,00	3	16410	62,21
MF14	1,50	70	22	11,00	9,00	4	82259	83,51
M14	2,00	80	30	11,00	9,00	4	16411	68,90
MF16	1,50	70	22	12,00	9,00	4	82290	86,51
M16	2,00	80	32	12,00	9,00	4	16412	94,42
MF18	1,50	80	22	14,00	11,00	4	82260	126,28
M18	2,50	95	40	14,00	11,00	4	16413	128,97
MF20	1,50	80	22	16,00	12,00	4	82261	122,90
M20	2,50	95	40	16,00	12,00	4	16414	143,20



Ref. **3037**

MACHO ÚNICO MÉTRICA COBALTO INOX

STAINLESS Cobalt Metric Hand Single Tap
Taraud à main unique métrique Cobalt INOX

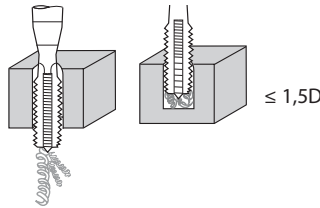
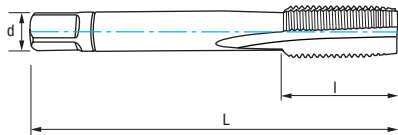

HSSE
5% Co

M
DIN
352

MF
DIN
2181

Tol.
6H

Vaporiz.

C
2-3h

α
6-8°

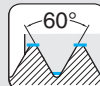

Grupo
Group-Gruppe
P

Subgrup.
P.5

INOX
Stainless Steel
Acier INOX

Fundición
Cast Iron
Fonte

Nº1 Desbaste
Roughing
Ébauche

Nº2 Semidesbaste
Semiroughing
Semi-ébauche

Nº3 Acabado
Finishing
Finition

Nº1-Nº2 Con guía
Guided
Avec guide

M	P	L mm	l mm	d mm	a mm	Z	Nº 3 Acabado Finishing Finition	Nº 1 Desbaste Roughing Ébauche	Nº 2 Semidesbaste Semiroughing Semi-Ébauche	€
M2	0,40	36	8	2,80	2,10	3	83127	83125	83126	11,87
M3	0,50	40	11	3,50	2,70	3	74981	74979	74980	9,50
M4	0,70	45	13	4,50	3,40	3	75010	74982	74983	9,50
M5	0,80	50	16	6,00	4,90	3	74986	74984	74985	9,89
MF6	0,75	56	14	6,00	4,90	3	82264	82262	82263	18,02
M6	1,00	56	19	6,00	4,90	3	74990	74988	74989	9,89
MF8	1,00	63	18	6,00	4,90	3	82267	82265	82266	18,02
M8	1,25	63	22	6,00	4,90	3	74993	74991	74992	11,49
MF10	1,00	63	18	7,00	5,50	3	82270	82268	82269	20,03
M10	1,50	70	24	7,00	5,50	3	74998	74994	74997	14,78
MF12	1,00	70	18	9,00	7,00	3	82273	82271	82272	22,88
MF12	1,50	70	22	9,00	7,00	3	82276	82274	82275	22,34
M12	1,75	75	29	9,00	7,00	3	75003	74999	75000	21,15
MF14	1,50	70	22	11,00	9,00	4	82279	82277	82278	27,84
M14	2,00	80	30	11,00	9,00	4	75006	75004	75005	23,43
MF16	1,50	70	22	12,00	9,00	4	82283	82280	82282	28,83
M16	2,00	80	32	12,00	9,00	4	74974	72865	72864	32,11
MF18	1,50	80	22	14,00	11,00	4	82286	82284	82285	42,07
M18	2,50	95	40	14,00	11,00	4	75009	75007	75008	43,86
MF20	1,50	80	22	16,00	12,00	4	82289	82287	82288	40,97
M20	2,50	95	40	16,00	12,00	4	59960	74131	74977	48,69



Ref. 3020

JUEGO MACHOS MANO MÉTRICA FINA

Metric Fine Hand Tap Set

Jeu de tarauds à main métrique pas fin

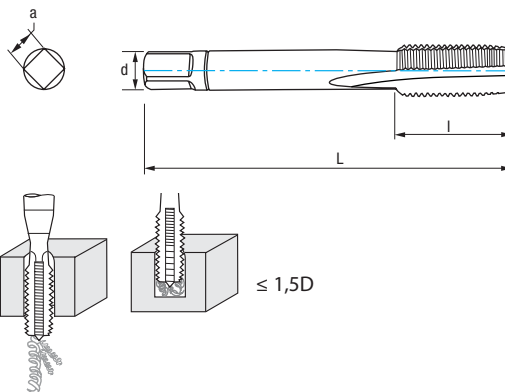

HSS	DIN 2181	Tol. 6H	C 2-3h	α 10° ± 2	60°	N°1 Desbaste Roughing Ébauche	N°3 Acabado Finishing Finition
-----	----------	---------	--------	-----------	-----	-------------------------------------	--------------------------------------

Aceros <850 N/mm ² Steel / Aciers	Fundición Cast Iron Fonte	Cobre Copper Cuivre	Aluminio Aluminium
---	--	----------------------------------	------------------------------

MF	P	L mm	l mm	d mm	a mm	Z	Nº Art.	€
MF4	0,50	45	10	4,50	4,90	3	62336	30,10
MF5	0,50	50	12	6,00	4,90	3	62342	29,95
MF5	0,75	50	12	6,00	4,90	3	62345	30,29
MF6	0,50	50	14	6,00	4,90	3	62351	21,40
MF6	0,75	50	14	6,00	4,90	3	62354	18,12
MF7	0,75	50	14	6,00	4,90	3	62360	27,58
MF8	0,50	50	19	6,00	4,90	4	62366	41,03
MF8	0,75	50	19	6,00	4,90	4	62369	24,91
MF8	1,00	56	20	6,00	4,90	4	62372	18,05
MF9	1,00	63	20	7,00	5,50	4	75090	30,62
MF10	0,50	63	20	7,00	5,50	4	21727	39,13
MF10	0,75	63	20	7,00	5,50	4	76309	46,31
MF10	1,00	63	20	7,00	5,50	4	62378	19,44
MF10	1,25	70	24	7,00	5,50	4	62381	19,69
MF11	0,75	63	20	8,00	6,20	4	16118	95,95
MF11	1,00	63	20	8,00	6,20	4	76311	42,70
MF11	1,25	63	20	8,00	6,20	4	75298	42,70
MF12	0,75	70	22	9,00	7,00	4	76312	53,03
MF12	1,00	70	20	9,00	7,00	4	62387	34,00
MF12	1,25	70	22	9,00	7,00	4	62390	34,07
MF12	1,50	70	22	9,00	7,00	4	62393	29,04
MF13	0,75	70	22	11,00	9,00	4	56832	95,95
MF13	1,00	70	20	11,00	9,00	4	76314	60,74
MF13	1,25	70	22	11,00	9,00	4	76315	53,66
MF13	1,50	70	22	11,00	9,00	4	62399	53,66
MF14	0,75	70	22	11,00	9,00	4	56833	94,46
MF14	1,00	70	20	11,00	9,00	4	62402	60,74
MF14	1,25	70	20	11,00	9,00	4	62405	41,61
MF14	1,50	70	20	11,00	9,00	4	62408	32,33
MF14	1,75	70	30	11,00	9,00	4	10875	124,01
MF15	1,00	70	20	12,00	9,00	4	76318	84,99
MF15	1,25	70	22	12,00	9,00	4	76319	77,45
MF15	1,50	70	20	12,00	9,00	4	75299	78,73
MF16	1,00	70	20	12,00	9,00	4	62414	85,04
MF16	1,25	70	20	12,00	9,00	4	76320	89,52
MF16	1,50	70	20	12,00	9,00	4	62417	40,47

MF	P	L mm	l mm	d mm	a mm	Z	Nº Art.	€
MF17	1,00	70	22	12,00	9,00	4	76321	114,16
MF17	1,25	70	22	12,00	9,00	4	56834	114,16
MF17	1,50	70	22	12,00	9,00	4	62420	114,16
MF18	1,00	80	22	14,00	11,00	4	62423	94,57
MF18	1,25	80	22	14,00	11,00	4	76323	112,52
MF18	1,50	80	22	14,00	11,00	4	62426	53,45
MF18	2,00	80	22	14,00	11,00	4	62429	100,89
MF19	1,00	80	22	14,00	11,00	4	10831	165,69
MF19	1,25	80	22	14,00	11,00	4	56835	165,56
MF19	1,50	80	22	14,00	11,00	4	76326	165,69
MF19	2,00	80	22	14,00	11,00	4	56837	197,37
MF20	1,00	80	22	16,00	12,00	4	76327	125,27
MF20	1,25	80	22	16,00	12,00	4	74816	165,69
MF20	1,50	80	22	16,00	12,00	4	62435	67,01
MF20	2,00	80	22	16,00	12,00	4	62438	105,05
MF21	1,00	80	22	16,00	12,00	4	56838	214,12
MF21	1,25	80	22	16,00	12,00	4	56840	214,12
MF21	1,50	80	22	16,00	12,00	4	75300	169,32
MF22	1,00	80	22	18,00	14,50	4	76330	140,41
MF22	1,25	80	22	18,00	14,50	4	74601	165,69
MF22	1,50	80	22	18,00	14,50	4	62441	73,07
MF22	2,00	80	22	18,00	14,50	4	62444	116,99
MF23	1,00	80	22	18,00	14,50	4	56841	213,91
MF23	1,50	80	22	18,00	14,50	4	56842	213,91
MF24	1,00	90	22	18,00	14,50	4	76333	131,48
MF24	1,25	90	22	18,00	14,50	4	62447	214,12
MF24	1,50	90	22	18,00	14,50	4	62450	93,25
MF24	2,00	90	22	18,00	14,50	4	62453	156,97
MF25	1,00	90	22	18,00	14,50	4	76334	187,35
MF25	1,25	90	22	18,00	14,50	4	56843	305,06
MF25	1,50	90	22	18,00	14,50	4	75301	184,08
MF25	2,00	90	22	18,00	14,50	4	56844	313,77
MF26	1,00	90	22	18,00	14,50	4	56846	163,72
MF26	1,50	90	22	18,00	14,50	4	75302	177,68
MF26	2,00	90	22	18,00	14,50	4	56847	180,23
MF27	1,00	90	22	20,00	16,00	4	76338	180,26

Cont.

Ref. **3020****JUEGO MACHOS MANO MÉTRICA FINA**

Metric Fine Hand Tap Set

Jeu de tarauds à main métrique pas fin

Cont.

MF	P	L mm	l mm	d mm	a mm	Z	Nº Art.	€
MF27	1,50	90	22	20,00	16,00	4	76339	195,90
MF27	2,00	90	22	20,00	16,00	4	75303	217,61
MF28	1,00	90	22	20,00	16,00	4	76340	305,34
MF28	1,50	90	22	20,00	16,00	4	76341	197,36
MF30	1,00	90	22	22,00	18,00	4	76342	189,46
MF30	1,50	90	22	22,00	18,00	4	76343	204,71
MF30	2,00	90	22	22,00	18,00	4	75304	235,96
MF32	1,50	90	22	22,00	18,00	4	76345	236,33
MF33	1,50	100	25	25,00	20,00	4	76348	277,78
MF33	2,00	100	25	25,00	20,00	4	75305	350,81
MF34	1,50	100	25	28,00	22,00	4	76349	289,52
MF35	1,50	100	25	28,00	22,00	4	76350	289,52
MF36	1,50	100	25	28,00	22,00	4	76351	318,88
MF36	2,00	125	33	28,00	22,00	4	76140	408,05
MF36	3,00	125	33	28,00	22,00	4	76352	468,14
MF38	1,50	100	25	28,00	22,00	4	76353	358,63
MF38	2,00	125	40	28,00	22,00	4	75306	426,31
MF39	1,50	110	25	32,00	24,00	4	76354	468,14
MF39	2,00	125	33	32,00	24,00	4	76355	559,12
MF39	3,00	125	33	32,00	24,00	4	76356	468,14
MF40	1,50	110	25	32,00	24,00	6	76357	421,28
MF40	2,00	110	25	32,00	24,00	6	76358	411,46
MF40	3,00	125	40	32,00	24,00	6	76359	407,64
MF42	2,00	125	33	32,00	24,00	6	76361	559,88
MF42	3,00	125	33	32,00	24,00	6	76362	559,88
MF45	1,50	110	25	36,00	29,00	6	76363	441,12
MF45	2,00	125	33	36,00	29,00	6	76364	672,16
MF45	3,00	125	33	36,00	29,00	6	76365	720,63
MF48	1,50	140	33	36,00	29,00	6	76366	497,08
MF48	2,00	140	33	36,00	29,00	6	76367	814,49
MF48	3,00	140	33	36,00	29,00	6	76368	814,55
MF50	1,50	140	40	36,00	29,00	6	76369	543,61
MF52	1,50	140	40	40,00	32,00	6	76370	576,68
MF52	2,00	140	40	40,00	32,00	6	77643	829,65
MF52	3,00	140	40	40,00	32,00	6	76372	770,27



Ref. 3010

MACHO ÚNICO MANO MÉTRICA/ MÉTRICA FINA

Metric / Metric Fine Hand Single Tap

Taroud à main unique métrique / métrique pas fin

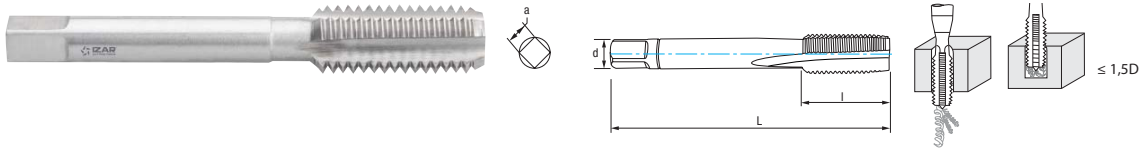

HSS

M
DIN
352

MF
DIN
2181

Tol.
6H



α
10° ± 2



Aceros
<850 N/mm²
Steel / Aciers

Fundición
Cast Iron
Fonte

Cobre
Copper
Cuivre

Aluminio
Aluminium

Nº3 Acabado
Finishing Finition
(M Ref. 3030 / MF Ref. 3020)

Nº 1 Desbaste M
Roughing Ébauche
(Ref. 3030)

Nº 2 Semidesbaste M
Semiroughing Semi-ébauche
(Ref. 3030)

M/MF	P	L mm	l mm	d mm	a mm	Z	Nº Art. HSS	€	Nº Art. HSS	€	Nº Art. HSS	€
M2	0,40	36	8	2,80	2,10	3	76385	9,13	22710	9,13	33368	9,13
M2	0,45	41	8	2,50	2,00	3	16451	9,13				
M2,5	0,45	40	9	2,80	2,10	3	76387	9,13				
M3	0,50	40	11	3,50	2,70	3	76389	5,19	11158	5,19	12723	5,19
M3,5	0,60	45	13	4,00	3,00	3	76391	6,13	66186	6,13	20538	6,13
MF4	0,50	45	10	4,50	4,90	3	76393	15,05				
M4	0,70	45	13	4,50	3,40	3	76394	5,19	18943	5,19	11263	5,19
M4,5	0,75	50	16	6,00	4,90	3	76397	9,15	66187	9,15	66192	9,15
MF5	0,50	50	12	6,00	4,90	3	59484	15,91				
MF5	0,75	50	12	6,00	4,90	3	59485	15,07				
M5	0,80	50	16	6,00	4,90	3	76400	5,51	11262	5,51	26620	5,51
MF6	0,50	50	14	6,00	4,90	3	59486	10,94				
MF6	0,75	50	14	6,00	4,90	3	76405	9,06				
M6	1,00	50	19	6,00	4,90	3	75383	5,51	10630	5,51	10833	5,51
MF7	0,75	50	14	6,00	4,90	3	46217	13,79				
M7	1,00	50	19	6,00	4,90	3	76408	6,73	66201	6,73	32812	6,73
MF8	0,50	50	19	6,00	4,90	4	59487	16,96				
MF8	0,75	50	19	6,00	4,90	4	59488	13,43				
MF8	1,00	56	20	6,00	4,90	4	76411	9,03				
M8	1,25	56	22	6,00	4,90	4	75449	6,73	10938	6,73	26629	6,73
MF9	1,00	63	20	7,00	5,50	4	34577	15,31				
M9	1,25	63	22	7,00	5,50	4	76414	10,98	66208	10,98	20543	10,98
MF10	0,50	63	20	7,00	5,50	4	59489	19,57				
MF10	0,75	63	20	7,00	5,50	4	59490	19,10				
MF10	1,00	63	20	7,00	5,50	4	76417	9,71				
MF10	1,25	70	24	7,00	5,50	4	76418	9,85				
M10	1,50	70	24	7,00	5,50	4	74995	8,24	11148	8,24	15086	8,24
MF11	0,75	63	20	8,00	6,20	4	59491	47,19				
MF11	1,00	63	20	8,00	6,20	4	59492	16,98				
MF11	1,25	63	22	8,00	6,20	4	59493	17,12				
M11	1,50	70	24	8,00	6,20	4	76422	13,76	25211	13,76	21282	13,76
MF12	0,75	70	22	9,00	7,00	4	59494	27,18				
MF12	1,00	70	20	9,00	7,00	4	22221	17,02				
MF12	1,25	70	22	9,00	7,00	4	76425	17,05				
MF12	1,50	70	22	9,00	7,00	4	76426	14,53				
M12	1,75	75	29	9,00	7,00	4	74996	11,61	10834	11,61	28407	11,61
MF13	0,75	70	22	11,00	9,00	4	59495	48,18				
MF13	1,00	70	20	11,00	9,00	4	59496	27,27				
MF13	1,25	70	22	11,00	9,00	4	59497	27,49				
MF13	1,50	70	22	11,00	9,00	4	59498	27,55				
MF14	0,75	70	22	11,00	9,00	4	59499	47,62				
MF14	1,00	70	20	11,00	9,00	4	76433	30,36				
MF14	1,25	70	20	11,00	9,00	4	45040	20,80				
MF14	1,50	70	20	11,00	9,00	4	76435	16,17				
MF14	1,75	70	30	11,00	9,00	4	59500	62,01				
M14	2,00	80	30	11,00	9,00	4	76436	12,83	11772	12,83	20529	12,83
MF15	1,00	70	20	12,00	9,00	4	59501	36,80				
MF15	1,25	70	22	12,00	9,00	4	59503	39,38				
MF15	1,50	70	20	12,00	9,00	4	76439	39,37				
MF16	1,00	70	22	12,00	9,00	4	59504	35,14				
MF16	1,25	70	22	12,00	9,00	4	59505	36,98				
MF16	1,50	70	20	12,00	9,00	4	76443	20,23				
M16	2,00	80	32	12,00	9,00	4	76444	18,20	17461	18,20	16312	18,20
MF17	1,00	70	22	12,00	9,00	4	59506	56,60				
MF17	1,25	70	22	12,00	9,00	4	59507	56,83				

MF Nº1
bajo demanda
upon request
sur demande

Cont.

Ref. **3010****Cont.**

Nº3 Acabado
Finishing Finition
(M Ref. 3030 / MF Ref. 3020)

Nº 1 Desbaste M
Roughing Ébauche
(Ref. 3030)

Nº 2 Semidesbaste M
Semiroughing Semi-Ébauche
(Ref. 3030)

M/MF	P	L mm	I mm	d mm	Ø mm	Z	Nº Art. HSS	€	Nº Art. HSS	€	Nº Art. HSS	€
MF17	1,50	70	22	12,00	9,00	4	59562	26,66				
MF18	1,00	80	22	14,00	11,00	4	59508	39,05				
MF18	1,25	80	22	14,00	11,00	4	59509	55,34				
MF18	1,50	80	22	14,00	11,00	4	45039	26,73				
MF18	2,00	80	22	14,00	11,00	4	59510	42,42				
M18	2,50	95	40	14,00	11,00	4	76452	24,13	11916	24,13	66249	24,13
MF19	1,25	80	22	14,00	11,00	4	59511	81,42				
MF19	1,50	80	22	14,00	11,00	4	59512	82,85				
MF19	2,00	80	22	14,00	11,00	4	59513	98,68				
MF20	1,00	80	22	16,00	12,00	4	59514	52,01				
MF20	1,25	80	22	16,00	12,00	4	59515	81,50				
MF20	1,50	80	22	16,00	12,00	4	76476	33,49				
MF20	2,00	80	22	16,00	12,00	4	59516	43,97				
M20	2,50	95	40	16,00	12,00	4	76478	27,17	11917	27,17	17261	27,17
MF21	1,00	80	22	16,00	12,00	4	59517	106,18				
MF21	1,25	80	22	16,00	12,00	4	59518	105,30				
MF21	1,50	80	22	16,00	12,00	4	59519	84,66				
MF22	1,00	80	22	18,00	14,50	4	59521	57,52				
MF22	1,25	80	22	18,00	14,50	4	59522	82,85				
MF22	1,50	80	22	18,00	14,50	4	76484	36,53				
MF22	2,00	80	22	18,00	14,50	4	76485	58,50				
M22	2,50	100	40	18,00	14,50	4	76486	36,35	65789	36,35	15241	36,35
MF23	1,00	80	22	18,00	14,50	4	59523	106,09				
MF23	1,50	80	22	18,00	14,50	4	59524	105,21				
MF24	1,25	90	22	18,00	14,50	4	59525	107,07				
MF24	2,00	90	22	18,00	14,50	4	59526	64,86				
M24	3,00	110	50	18,00	14,50	4	76493	42,60	58475	42,60	12505	42,60
MF25	1,00	90	22	18,00	14,50	4	59527	92,92				
MF25	1,25	90	22	18,00	14,50	4	59528	150,03				
MF25	2,00	90	22	18,00	14,50	4	59561	156,88				
MF26	1,00	90	22	18,00	14,50	4	59529	81,85				
MF26	1,50	90	22	18,00	14,50	4	59530	73,38				
MF26	2,00	90	22	18,00	14,50	4	59531	90,11				
MF27	1,00	90	22	20,00	16,00	4	59532	91,18				
MF27	1,50	90	22	20,00	16,00	4	59533	81,32				
M27	3,00	110	50	20,00	16,00	4	76505	54,85	10836	54,85	66294	54,85
MF28	1,00	90	22	20,00	16,00	4	59534	151,41				
MF28	1,50	90	22	20,00	16,00	4	59535	81,52				
MF30	1,00	90	22	22,00	18,00	4	16388	113,72				
MF30	1,50	90	22	22,00	18,00	4	59536	84,56				
M30	3,50	125	56	22,00	18,00	4	76512	70,23	26582	70,23	13046	70,23
MF33	1,50	100	25	25,00	20,00	4	59537	114,71				
MF33	2,00	100	25	25,00	20,00	4	59538	136,39				
M33	3,50	125	56	25,00	20,00	4	76519	88,58	66307	88,58	66308	88,58
MF34	1,50	100	25	28,00	22,00	4	59539	124,13				
MF35	1,50	100	25	28,00	22,00	4	59540	137,66				
MF36	1,50	100	25	28,00	22,00	4	59541	132,95				
MF36	3,00	125	40	28,00	22,00	4	59542	232,13				
M36	4,00	150	63	28,00	22,00	4	76525	113,02	66317	113,02	38036	113,02
MF38	1,50	100	25	28,00	22,00	4	59543	149,58				
MF38	2,00	125	40	28,00	22,00	4	59544	213,16				
MF39	1,50	110	25	32,00	24,00	4	59545	200,60				
MF39	2,00	125	40	32,00	24,00	4	59546	198,94				
MF39	3,00	125	40	28,00	22,00	4	59547	196,83				
M39	4,00	150	63	32,00	24,00	4	76531	126,45	66328	126,45	66329	126,45
MF40	1,50	110	25	32,00	24,00	4	59548	177,12				
MF40	2,00	125	40	32,00	24,00	4	59549	202,35				
MF40	3,00	125	40	32,00	24,00	4	59550	203,83				
MF42	1,50	110	25	32,00	24,00	4	14781	234,34				
MF42	2,00	125	40	32,00	24,00	4	59551	235,37				
MF42	3,00	125	40	32,00	24,00	4	59552	231,52				
M42	4,50	150	63	32,00	24,00	4	76538	158,21	66342	158,21	61071	158,21
MF45	1,50	110	25	36,00	29,00	6	16389	264,75				
MF45	2,00	125	40	36,00	29,00	6	59553	275,62				
MF45	3,00	125	40	36,00	29,00	6	59554	280,21				
M45	4,50	160	70	36,00	29,00	6	76542	182,65	32663	182,65	32664	182,65
MF48	1,50	140	40	36,00	29,00	6	16390	298,39				
MF48	2,00	140	40	36,00	29,00	6	59555	368,68				
MF48	3,00	140	40	36,00	29,00	6	59556	333,69				
M48	5,00	180	75	36,00	29,00	6	76546	219,91	66355	219,91	66356	219,91
MF50	1,50	140	40	36,00	29,00	6	59557	267,35				
MF52	1,50	140	40	40,00	32,00	6	59558	285,98				
MF52	2,00	140	40	40,00	32,00	6	59559	414,83				
MF52	3,00	140	40	40,00	32,00	6	59560	378,83				
M52	5,00	180	75	40,00	32,00	6	76551	266,94	66367	266,94	66368	266,94

MF Nº1
bajo demanda
upon request
sur demande

Ref. **3001**

MACHO ÚNICO MANO MÉTRICA

Metric Hand **Single Tap**
Taraud à main **unique** métrique

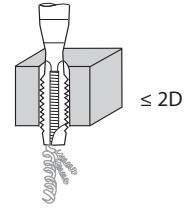
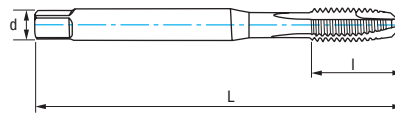

HSS

DIN 352

Tol. 6H

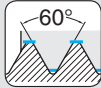

Nº3 Acabado
Finishing
Finition

Aceros
<850 N/mm²
Steel / Aciers

Fundición
Cast Iron
Fonte

Cobre
Copper
Cuivre

Aluminio
Aluminium



M	P	L mm	l mm	d mm	a mm	Z	Nº Art.	€
M3	0,50	40	11	3,50	2,70	3	25217	5,13
M4	0,70	45	13	4,00	3,00	3	25218	5,13
M5	0,80	50	16	6,00	4,90	3	25219	5,45
M6	1,00	56	19	6,00	4,90	3	25220	5,45
M8	1,25	56	22	6,00	4,90	4	25222	6,66
M10	1,50	70	24	7,00	5,50	4	25224	8,18
M12	1,75	75	29	9,00	7,00	3	25374	11,51

Línea 33 cm
3001

MACHO ÚNICO MANO MÉTRICA

Metric Hand **Single Tap**
Taraud à main **unique** métrique

21
cm



∅	M3	M5	M6	M8	M10
Pcs	3	3	3	3	3

Ref. 4995 - Nº Art. 72118: **92,59 €**



Ref. **3023**

MACHO MANO PERFIL ROSCA COMPLETA

Whole Thread Profile Hand Tap

Taraud à main profil filetage complet

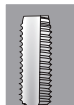
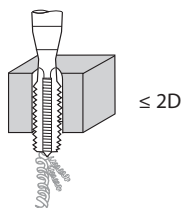
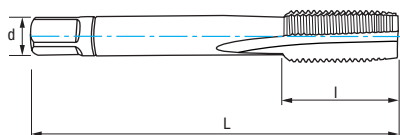

HSS	DIN 352	Tol. 6H	α $10^\circ \pm 2$	4-6h	60°
Aceros <math><850 \text{ N/mm}^2</math> Steel / Aciers	Fundición Cast Iron Fonte	Cobre Copper Cuivre	Aluminio Aluminium		



Macho único que **finaliza la rosca completa** en agujeros pasantes. Espesor material <math><1,5 \text{ mm}</math>. Viruta media/larga.

Single tap for **whole thread finishing** in through holes. Material thickness <math><1,5 \text{ mm}</math>. Medium/long chip removal.

Guidage et filetage complet sur trous débouchants. Épaisseur matériel <math><1,5 \text{ mm}</math>. Copeaux moyens/longs.

M	P	L mm	l mm	d mm	a mm	Z	N° Art.	€
M3	0,50	40	11	3,50	2,70	3	46263	7,78
M4	0,70	45	13	4,50	3,40	3	46264	7,78
M5	0,80	50	16	6,00	4,90	3	46265	8,25
M6	1,00	50	19	6,00	4,90	3	46266	8,25
M8	1,25	56	22	6,00	4,90	4	46267	10,08
M10	1,50	70	24	7,00	5,50	4	46268	12,38
M12	1,75	75	29	9,00	7,00	4	46269	17,43
M16	2,00	80	32	12,00	9,00	4	46270	27,30
M20	2,50	95	40	16,00	12,00	4	46271	40,75

Línea 33 cm
3023

MACHO MANO PERFIL ROSCA COMPLETA

Whole Thread Profile Hand Tap

Taraud à main profil filetage complet



o	M3	M4	M5	M6	M8	M10
Pcs	5	5	5	5	5	5

Ref. 4995 - N° Art. 72121: 272,61 €



Ref. **3040**

JUEGO MACHOS MANO RÁPIDO MÉTRICA NORMA ISO

ISO Standard Metric Fast Hand Tap Set

Jeu de tarauds à main rapide métrique norme ISO

Nº3  **C 2-3h**

Nº3  **D 5h**

Nº3  **A 8h**

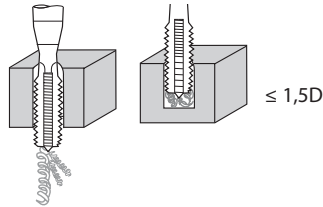
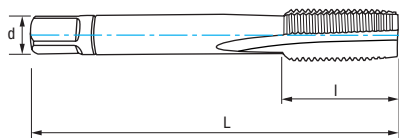

HSS

ISO
529

Tol.
6H

A 8h

D 5h

C 2-3h

α
 $10^\circ \pm 2$

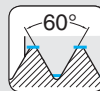

Aceros
<math><850 \text{ N/mm}^2</math>
Steel / Aciers

Fundición
Cast Iron
Fonte

Cobre
Copper
Cuivre

Aluminio
Aluminium



M	P	L mm	I mm	d mm	a mm	Z	Nº Art.	€
M2	0,40	41	8	2,50	2,00	3	83527	26,72
M3	0,50	48	11	3,15	2,50	3	68870	15,12
M4	0,70	53	13	4,00	3,15	3	68871	15,12
M5	0,80	58	16	5,00	4,00	3	68872	16,03
M6	1,00	66	19	6,30	5,00	3	68873	16,03
M8	1,25	72	22	8,00	6,30	4	68874	19,59
M10	1,50	80	24	10,00	8,00	4	68875	24,06
M12	1,75	89	29	9,00	7,10	4	68876	33,82
M14	2,00	95	30	11,20	9,00	4	68877	37,41
M16	2,00	102	32	12,50	10,00	4	68878	53,08



Ref. **3032**

JUEGO MACHOS MANO BSW (WHITWORTH)

BSW (Whitworth) Hand Tap Set

Jeu de tarauds à main BSW (Whitworth)

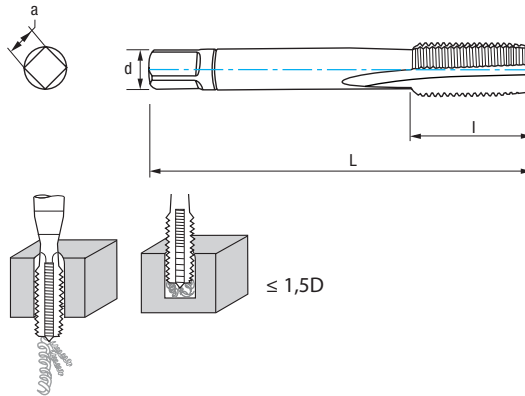

HSS

DIN 352

C
2-3h

α
 $10^\circ \pm 2$

55°

Rosca Whitworth cilíndrica
Straight Whitworth Thread
Filetage Whitworth cylindrique

Aceros
<850 N/mm²
Steel / Aciers

Fundición
Cast Iron
Fonte

Cobre
Copper
Cuivre

Aluminio
Aluminium



W	Hilos Threads Filets	L mm	l mm	d mm	a mm	Z	Nº Art.	€
W3/32	48,00	36	10	2,80	2,10	3	62663	29,51
W1/8	40,00	40	12	3,50	2,70	3	62642	24,01
W5/32	32,00	45	14	4,50	3,40	3	62675	24,01
W3/16	24,00	50	18	6,00	4,90	3	62660	24,01
W7/32	24,00	50	18	6,00	4,90	3	62684	36,30
W1/4	20,00	50	19	6,00	4,90	3	62633	27,32
W5/16	18,00	56	22	6,00	4,90	4	62669	32,52
W3/8	16,00	70	24	7,00	5,50	4	62654	35,98
W7/16	14,00	70	24	8,00	6,20	4	62681	47,13
W1/2	12,00	75	29	9,00	7,00	4	62630	52,07
W9/16	12,00	80	30	11,00	9,00	4	62687	70,35
W5/8	11,00	80	32	12,00	9,00	4	62666	81,38
W3/4	10,00	95	40	14,00	11,00	4	62645	115,82
W7/8	9,00	100	40	18,00	14,50	4	62678	143,84
W1"	8,00	110	50	18,00	14,50	4	62693	177,60
W1"1/8	7,00	132	56	22,00	18,00	4	62702	263,29
W1"1/4	7,00	132	56	22,00	18,00	4	62699	311,41
W1"3/8	6,00	150	63	28,00	22,00	4	42713	387,30
W1"1/2	6,00	150	63	32,00	24,00	4	62696	466,28
W1"5/8	5,00	160	70	32,00	24,00	4	59880	600,51
W1"3/4	5,00	160	70	36,00	29,00	6	59881	739,10
W1"7/8	4,50	190	80	36,00	29,00	6	59882	954,60
W2"	4,50	190	80	40,00	32,00	6	59883	1.002,14



Ref. **3012**

MACHO ÚNICO MANO BSW (WHITWORTH)

BSW (Whitworth) Hand Tap
Taraud à main BSW (Whitworth)

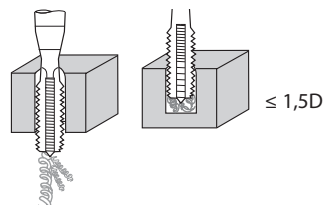
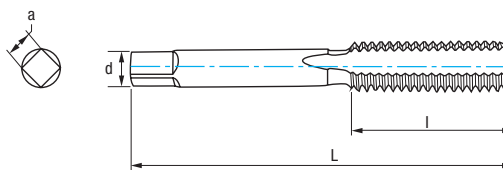

HSS

DIN
352



α
 $10^\circ \pm 2$

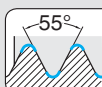

Rosca Whitworth cilíndrica
Straight Whitworth Thread
Filetage Whitworth cylindrique

Nº3 Acabado
Finishing
Finition

Aceros
<math><850 \text{ N/mm}^2</math>
Steel / Aciers

Fundición
Cast Iron
Fonte

Cobre
Copper
Cuivre

Aluminio
Aluminium

W	Hilos Threads	Filets Filets	L mm	l mm	d mm	a mm	Z	Nº Art.	€
W3/32	48,00		40	9	2,80	2,10	3	75404	9,84
W1/8	40,00		40	14	3,50	2,70	3	75401	8,02
W5/32	32,00		45	17	4,50	3,40	3	75069	8,02
W3/16	24,00		50	19	6,00	4,90	3	74825	8,02
W7/32	24,00		50	19	6,00	4,90	3	75409	12,11
W1/4	20,00		50	20	6,00	4,90	3	75400	9,09
W5/16	18,00		56	20	6,00	4,90	4	75406	10,86
W3/8	16,00		63	22	7,00	5,50	4	75403	11,99
W7/16	14,00		70	22	8,00	6,20	4	75408	15,71
W1/2	12,00		75	25	9,00	7,00	4	75399	17,35
W9/16	12,00		80	26	11,00	9,00	4	75448	23,42
W5/8	11,00		80	27	12,00	9,00	4	75405	27,12
W3/4	10,00		95	32	14,00	11,00	4	75402	38,61
W7/8	9,00		100	32	18,00	14,50	4	75407	47,95
W1"	8,00		110	36	18,00	14,50	4	75410	59,21
W1" 1/8	7,00		125	40	22,00	18,00	4	76255	87,76
W1" 1/4	7,00		125	40	22,00	18,00	4	76259	105,69
W1" 3/8	6,00		150	50	28,00	22,00	4	76264	132,05
W1" 1/2	6,00		150	50	32,00	24,00	4	76269	159,00
W1" 5/8	5,00		150	56	32,00	24,00	4	76274	207,46
W1" 3/4	5,00		160	58	36,00	29,00	4	76280	255,23
W1" 7/8	4,50		180	65	36,00	29,00	4	76286	329,66
W2"	4,50		180	65	40,00	32,00	4	76291	346,09



Ref. **3026**

JUEGO MACHOS MANO BSP (GAS)

BSP (Gas) Hand Tap Set
Jeu tarauds à main BSP (Gaz)

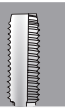
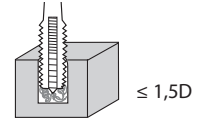
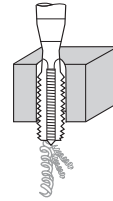
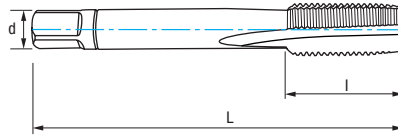

HSS **DIN 5157** **C 2-3h** α $10^\circ \pm 2$ **N°1 Desbaste Roughing Ébauche** **N°3 Acabado Finishing Finition** **Rosca Whitworth Paralela (BSPP) Whitworth Parallel Thread (BSPP) Filetage Whitworth Parallèle (BSPP)**

Aceros <850 N/mm² Steel / Aciers **Fundición Cast Iron Fonte** **Cobre Copper Cuivre** **Aluminio Aluminium**

G	Hilos Threads Filets	L mm	l mm	d mm	a mm	Z	N° Art.	€
G1/8	28	63	20	7	5,50	3	62510	24,62
G1/4	19	70	22	11	9,00	4	62504	34,64
G3/8	19	70	22	12	9,00	4	62516	43,51
G1/2	14	80	22	16	12,00	4	62498	61,08
G5/8	14	80	22	18	14,50	4	62522	78,11
G3/4	14	90	22	20	16,00	4	62513	95,36
G7/8	14	90	22	22	18,00	4	62525	127,19
G1"	11	100	25	25	20,00	4	62528	151,10

G	Hilos Threads Filets	L mm	l mm	d mm	a mm	Z	N° Art.	€
G1" 1/8	11	125	40	28	22,00	4	76195	279,40
G1" 1/4	11	125	40	32	24,00	4	76203	304,51
G1" 3/8	11	125	40	36	29,00	4	76211	413,61
G1" 1/2	11	140	40	36	29,00	6	74823	460,24
G1" 3/4	11	140	40	40	32,00	6	76225	765,15
G2"	11	160	40	45	35,00	8	76231	848,19

Ref. **3016**

MACHO ÚNICO MANO BSP (GAS)

BSP (Gas) Hand Tap
Taraud à main BSP (Gaz)

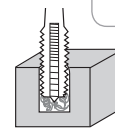
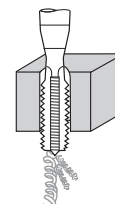
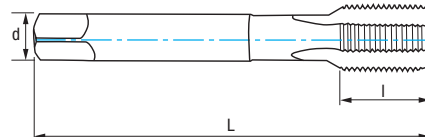
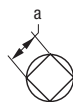

HSS **DIN 5157** **C 2-3h** α $10^\circ \pm 2$ **N°3 Acabado Finishing Finition**

Aceros <850 N/mm² Steel / Aciers **Fundición Cast Iron Fonte** **Cobre Copper Cuivre** **Aluminio Aluminium**

G	Hilos Threads Filets	L mm	l mm	d mm	a mm	Z	N° Art.	€
G1/8	28	63	20	7	5,50	3	75461	12,34
G1/4	19	70	22	11	9,00	4	75460	17,33
G3/8	19	70	22	12	9,00	4	75462	21,77
G1/2	14	80	22	16	12,00	4	75459	30,52
G5/8	14	80	22	18	14,50	4	75463	39,06
G3/4	14	90	22	20	16,00	4	75106	47,66
G7/8	14	90	22	22	18,00	4	76246	63,59
G1"	11	100	25	25	20,00	4	75464	75,55

G	Hilos Threads Filets	L mm	l mm	d mm	a mm	Z	N° Art.	€
G1" 1/8	11	125	40	28	22,00	4	76196	139,70
G1" 1/4	11	125	40	32	24,00	4	76204	152,23
G1" 3/8	11	140	40	36	29,00	4	76212	206,82
G1" 1/2	11	140	40	36	29,00	6	76218	230,11
G1" 3/4	11	140	40	40	32,00	6	76226	382,56
G2"	11	160	40	45	35,00	8	76232	424,09

Ref. **3100**

MACHO RECTO MÁQUINA MÉTRICA MANGO REFORZADO

Reinforced Shank Metric Machine Straight Tap
Taraud droit machine métrique queue renforcée

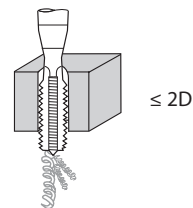
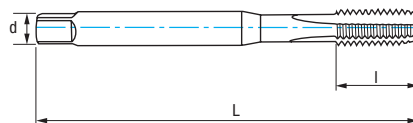

HSSE
5% Co

DIN
371

Reforzado
Reinforced
Renforcée

B
3,5-5h



Tol.
6H

α
 $10^\circ \pm 2$



Aceros
<math><850 \text{ N/mm}^2</math>
Steel / Aciers

Cobre
Copper
Cuivre

Aluminio
Aluminium

M	P	L mm	l mm	d mm	a mm	Z	Nº Art.	€
M2	0,40	45	9	2,80	2,10	3	62771	15,39
M2,5	0,45	50	9	2,80	2,10	3	76724	15,39
M2,6	0,45	50	9	2,80	2,10	3	76725	15,39
M3	0,50	56	11	3,50	2,70	3	62774	8,73
M3,5	0,60	56	13	4,00	3,00	3	62777	13,83
M4	0,70	63	13	4,50	3,40	3	62780	9,23
M4,5	0,75	70	16	6,00	4,90	3	76728	20,94
M5	0,80	70	16	6,00	4,90	3	62783	9,23
M6	1,00	80	19	6,00	4,90	3	62789	10,14
M7	1,00	80	19	7,00	5,50	3	76733	16,04
M8	1,25	90	22	8,00	6,20	3	62795	11,34
M9	1,25	90	18	9,00	7,00	3	62798	18,94
M10	1,50	100	24	10,00	8,00	3	62807	13,96



Expo 25 Pcs

Cont. Ø	Nº Art.	€
Machos / Taps / Tarauds DIN 371: M4-M5-M6-M8-M10 (5 pcs x M)	38998	269,49

Set Ref. 3100



7 Pcs

Cont. Ø	Nº Art.	€
Machos / Taps / Tarauds DIN 371: M3-M4-M5-M6-M8-M10 + DIN 376: M12	43348	80,30

Set Ref. 3100
+ 1010 HSS



14 Pcs

Cont. Ø	Nº Art.	€
Machos / Taps / Tarauds DIN 371: M3-M4-M5-M6-M8-M10 + DIN 376: M12 Brocas / Drill Bits / Forets HSS: 2,5-3,3-4,2-5,0-6,8-8,5-10,2	43354	92,48

Set Ref. 3100
+ 1016 HSSE



14 Pcs

Cont. Ø	Nº Art.	€
Machos / Taps / Tarauds DIN 371: M3-M4-M5-M6-M8-M10 + DIN 376: M12 Brocas / Drill Bits / Forets HSSE: 2,5-3,3-4,2-5,0-6,8-8,5-10,2	21801	102,76

Ref. **3200**

MACHO RECTO MÁQUINA MÉTRICA/ MÉTRICA FINA

Metric / Metric Fine Machine Straight Tap

Taraud droit machine métrique / métrique pas fin

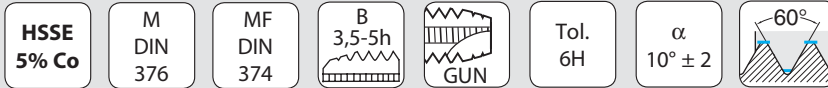
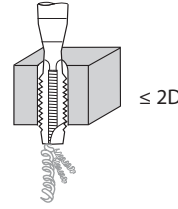
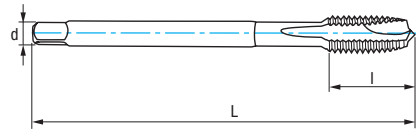

Aceros
<850 N/mm²
Steel / Aciers

Cobre
Copper
Cuivre

Aluminio
Aluminium

M/MF	P	L mm	l mm	d mm	a mm	Z	Nº Art.	€
M3	0,50	56	11	2,20			70090	9,32
M4	0,70	63	13	2,80	2,10	3	70092	9,44
M5	0,80	70	16	3,50	2,70	3	70093	9,44
M6	1,00	80	19	4,50	3,40	3	70095	10,37
M7	1,00	80	19	5,50	4,30	3	70224	16,47
MF8	0,75	80	19	6,00	4,90	3	70267	24,02
MF8	1,00	90	22	6,00	4,90	3	70248	19,47
M8	1,25	90	22	6,00	4,90	3	70096	11,64
MF10	1,00	90	20	7,00	5,50	3	70249	21,70
MF10	1,25	100	24	7,00	5,50	3	70251	25,87
M10	1,50	100	24	7,00	5,40	3	70098	14,34
M11	1,50	100	24	8,00	6,20	3	70225	27,67
MF12	1,00	100	22	9,00	7,00	3	70252	28,58
MF12	1,25	100	22	9,00	7,00	3	70254	28,86
MF12	1,50	100	22	9,00	7,00	3	70255	25,78
M12	1,75	110	29	9,00	7,00	3	70183	17,67
MF14	1,00	100	22	11,00	9,00	3	70281	43,81
MF14	1,25	100	22	11,00	9,00	3	70257	38,40
MF14	1,50	100	22	11,00	9,00	3	70258	30,52
M14	2,00	110	30	11,00	9,00	3	70185	28,34
MF15	1,50	100	22	12,00	9,00	3	70282	48,64
MF16	1,50	100	22	12,00	9,00	3	70260	38,15
M16	2,00	110	32	12,00	9,00	3	70186	33,36
MF18	1,00	110	25	14,00	11,00	3	70284	61,04
MF18	1,50	110	25	14,00	11,00	3	70261	47,73
MF18	2,00	125	34	14,00	11,00	3	70285	61,59
M18	2,50	125	34	14,00	11,00	3	75215	47,24
MF20	1,00	125	25	16,00	12,00	3	70287	80,56
MF20	1,50	125	25	16,00	12,00	3	70263	53,96
MF20	2,00	140	34	16,00	12,00	3	70288	70,77
M20	2,50	140	34	16,00	12,00	3	70189	51,08
MF22	1,50	125	25	18,00	14,50	3	75216	65,02
MF22	2,00	140	34	18,00	14,50	3	70290	103,04
M22	2,50	140	34	18,00	14,50	3	70212	61,78
MF24	1,50	140	28	18,00	14,50	4	70264	79,93
MF24	2,00	140	28	18,00	14,50	4	70291	101,04
M24	3,00	160	38	18,00	14,50	4	70213	73,45
MF26	1,50	140	28	18,00	14,50	4	70293	102,72

Ref. **3200**

MACHO RECTO MÁQUINA MÉTRICA/ MÉTRICA FINA

Metric / Metric Fine Machine Straight Tap

Taraud droit machine métrique / métrique pas fin

M/MF	P	L mm	l mm	d mm	a mm	Z	Nº Art.	€
MF27	2,00	140	28	20,00	16,00	4	70294	140,10
M27	3,00	160	38	20,00	16,00	4	70215	92,05
MF28	1,50	140	28	20,00	16,00	4	70296	117,48
MF30	1,50	150	28	22,00	18,00	4	70266	122,70
M30	3,50	180	45	22,00	18,00	4	70216	118,28
MF32	1,50	150	28	22,00	18,00	4	70297	146,85
MF33	1,50	160	30	25,00	20,00	4	70299	167,89
MF33	2,00	160	30	25,00	20,00	4	70300	242,58
M33	3,50	180	50	25,00	20,00	4	70218	148,77
MF35	1,50	170	30	28,00	22,00	4	70302	194,49
MF36	1,50	170	30	28,00	22,00	4	81355	215,59
MF36	2,00	170	30	28,00	22,00	4	81356	215,78
MF36	3,00	200	42	28,00	22,00	4	81357	247,55
M36	4,00	200	56	28,00	22,00	4	70219	181,75
MF39	1,50	170	30	32,00	24,00	4	81358	243,66
MF39	2,00	170	30	32,00	24,00	4	81359	216,20
MF39	3,00	200	42	32,00	24,00	4	81360	208,31
M39	4,00	200	50	32,00	24,00	4	81361	203,66
MF42	1,50	170	30	32,00	24,00	4	81362	228,47
MF42	2,00	170	30	32,00	24,00	4	81363	223,97
MF42	3,00	200	50	32,00	24,00	4	81364	347,04
M42	4,50	200	56	32,00	24,00	4	14886	261,82
MF45	1,50	180	32	36,00	29,00	6	70303	340,76
M45	4,50	220	56	36,00	29,00	6	81365	330,70
M48	5,00	250	63	36,00	29,00	6	81366	474,85
M52	5,00	250	63	40,00	32,00	6	81367	534,20
M56	5,50	250	65	40,00	32,00	6	81368	585,07
M60	5,50	280	75	45,00	35,00	6	81369	621,81



Expo 25 Pcs

Cont.	Nº Art.	€
Machos / Taps / Tarauds		
DIN 376: M4-M5-M6-M8-M10	39000	276,12
(5 pcs x M)		



Ref. **3150**

MACHO HELICOIDAL MÁQUINA MÉTRICA M. REFORZADO

Reinforced Shank Metric Machine Spiral Tap

Taroud hélicoïdal machine métrique queue renforcée

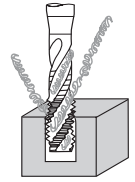
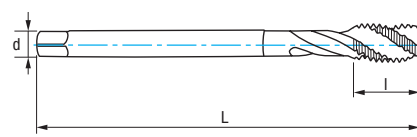

< 2D

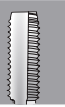

HSSE 5% Co	DIN 371	Reforzado Reinforced Renforcée	C 2-3h		α 10° ± 2	
----------------------	------------	---	-----------	--	---------------------	--

Aceros
<850 N/mm²
Steel / Aciers

Cobre
Copper
Cuivre

Aluminio
Aluminium



M	P	L mm	l mm	d mm	a mm	Z	Nº Art.	€
M3	0,50	56	5	3,50	2,70	3	63050	11,51
M3,5	0,60	56	6	4,00	3,00	3	63053	16,92
M4	0,70	63	7	4,50	3,40	3	63056	11,51
M5	0,80	70	8	6,00	4,90	3	63059	10,98
M6	1,00	80	10	6,00	4,90	3	63062	12,06
M7	1,00	80	10	7,00	5,50	3	63065	18,79
M8	1,25	90	13	8,00	6,20	3	63071	13,78
M9	1,25	90	13	9,00	7,00	3	67882	23,49
M10	1,50	100	15	10,00	8,00	3	63083	16,34



Expo 25 Pcs

Cont. Ø	Nº Art.	€
Machos / Taps / Tarauds DIN 371: M4-M5-M6-M8-M10 (5 pcs x M)	38999	323,34

Set Ref. 3150



7 Pcs

Set Ref. 3150
+ 1010 HSS



14 Pcs

Set Ref. 3150
+ 1016 HSSE



14 Pcs

Cont. Ø	Nº Art.	€
Machos / Taps / Tarauds DIN 371: M3-M4-M5-M6-M8-M10 + DIN 376: M12	43353	97,11

Cont. Ø	Nº Art.	€
Machos / Taps / Tarauds DIN 371: M3-M4-M5-M6-M8-M10 + DIN 376: M12 Brocas / Drill Bits / Forets HSS: 2,5-3,3-4,2-5,0-6,8-8,5-10,2	43359	109,29

Cont. Ø	Nº Art.	€
Machos / Taps / Tarauds DIN 371: M3-M4-M5-M6-M8-M10 + DIN 376: M12 Brocas / Drill Bits / Forets HSSE: 2,5-3,3-4,2-5,0-6,8-8,5-10,2	21802	119,57

Ref. **3250**

MACHO HELICOIDAL MÁQUINA MÉTRICA / MÉTRICA FINA

Metric / Metric Fine Machine Spiral Tap

Taraud hélicoïdal machine métrique / métrique pas fin

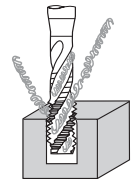
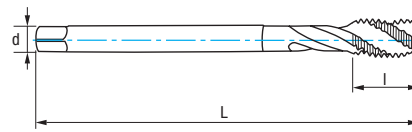

< 2D

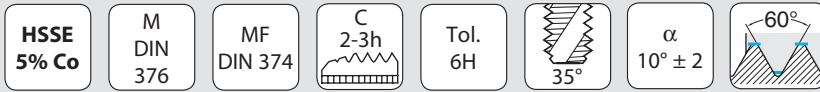

Aceros
<850 N/mm²
Steel / Aciers

Cobre
Copper
Cuivre

Aluminio
Aluminium

M/MF	P	L mm	l mm	d mm	a mm	Z	Nº Art.	€
M3	0,50	56	5	2,20		3	70063	11,22
M4	0,70	63	7	2,80	2,10	3	70065	11,13
M5	0,80	70	8	3,50	2,70	3	70066	10,66
M6	1,00	80	10	4,50	3,40	3	70068	11,68
MF8	1,00	90	13	6,00	4,90	3	70228	23,09
M8	1,25	90	13	6,00	4,90	3	70069	13,70
MF10	1,00	90	12	7,00	5,50	3	70230	27,22
MF10	1,25	100	15	7,00	5,50	3	70231	29,63
M10	1,50	100	15	7,00	5,50	3	70071	16,28
MF12	1,00	100	14	9,00	7,00	3	70233	33,81
MF12	1,25	100	14	9,00	7,00	3	70234	32,36
MF12	1,50	100	14	9,00	7,00	3	70236	31,13
M12	1,75	110	18	9,00	7,00	3	70161	20,94
MF14	1,25	100	16	11,00	9,00	3	70237	47,80
MF14	1,50	100	16	11,00	9,00	3	70239	38,27
M14	2,00	110	20	11,00	9,00	3	70162	32,87
MF16	1,50	100	16	12,00	9,00	3	70240	47,05
M16	2,00	110	20	12,00	9,00	4	70164	39,71
MF18	1,50	110	20	14,00	11,00	4	70242	56,83
M18	2,50	125	25	14,00	11,00	4	75057	53,47
MF20	1,50	125	20	16,00	12,00	4	70243	64,91
M20	2,50	140	25	16,00	12,00	4	70167	56,92
MF22	1,50	125	20	18,00	14,50	4	75192	84,95
M22	2,50	140	25	18,00	14,50	4	70206	70,23
MF24	1,50	140	22	18,00	14,50	4	70245	95,15
MF24	2,00	140	28	18,00	14,50	4	24326	99,88
M24	3,00	160	30	18,00	14,50	4	70207	84,06
M27	3,00	160	30	20,00	16,00	4	70209	105,01
MF30	1,50	150	28	22,00	18,00	4	70246	146,31
M30	3,50	180	35	22,00	18,00	4	70210	134,50



Expo 25 Pcs

Cont. Ø	Nº Art.	€
Machos / Taps / Tarauds DIN 376: M4-M5-M6-M8-M10 (5 pcs x M)	39001	317,24

Ref. **3119**

MACHO RECTO MÁQUINA MÉTRICA ISO MANGO REFORZADO

Reinforced Shank ISO Standard Metric Machine Straight Tap
Taraud droit machine métrique norme ISO queue renforcée

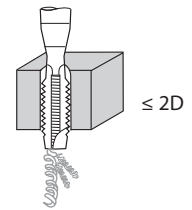
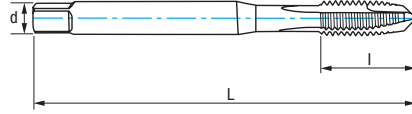

HSSE 5% Co	ISO 529	B 4-5h	Tol. 6H	GUN	α $10^\circ \pm 2$	60°
----------------------	-------------------	------------------	------------	------------	------------------------------	------------

Aceros <math><850 \text{ N/mm}^2</math> Steel / Aciers	Cobre Copper Cuivre	Aluminio Aluminium
---	----------------------------------	------------------------------

M	P	L mm	l mm	d mm	a mm	Z	Nº Art.	€
M3	0,50	48	11	3,15	2,50	3	69558	7,79
M4	0,70	53	13	4,00	3,15	3	69567	7,79
M5	0,80	58	16	5,00	4,00	3	69575	7,79
M6	1,00	66	19	6,30	5,00	3	69582	7,79
M8	1,25	72	22	8,00	6,30	3	69586	10,40
M10	1,50	80	24	10,00	8,00	3	69588	13,23

Línea 33 cm
3119

MACHO RECTO MÁQUINA MÉTRICA ISO MANGO REFORZADO

Reinforced Shank ISO Standard Metric Machine Straight Tap
Taraud droit machine métrique norme ISO queue renforcée



o	M3	M5	M6	M8	M10
Pcs	3	3	3	3	3

Ref. 4995 - Nº Art. 70993: 141,00 €



Ref. **3217**

MACHO RECTO MÁQUINA MÉTRICA NORMA ISO

ISO Standard Metric Machine Straight Tap

Taraut droit machine métrique norme ISO

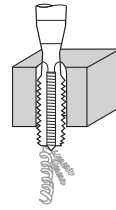
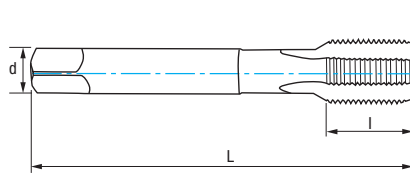

$\le 1,5D$

HSSE
5% Co

ISO
529



Tol.
6H



α
 $10^\circ \pm 2$



Aceros
<math><850 \text{ N/mm}^2</math>
Steel / Aciers

Cobre
Copper
Cuivre

Aluminio
Aluminium



M	P	L mm	l mm	d mm	a mm	Z	Nº Art.	€
M12	1,75	89	29	9,00	7,10	3	69607	17,02
M14	2,00	95	30	11,20	9,00	3	69608	20,33
M16	2,00	102	32	12,50	10,00	3	69610	25,24
M18	2,50	112	37	14,00	11,20	3	69611	38,00
M20	2,50	112	37	14,00	11,20	3	69613	42,49
M22	2,50	118	38	16,00	12,50	3	69614	49,12
M24	3,00	130	45	18,00	14,00	3	69616	55,49
M27	3,00	135	45	20,00	16,00	3	69617	68,35
M30	3,50	138	48	20,00	16,00	3	69619	101,52



Ref. **3109**

MACHO RECTO MÁQUINA MÉTRICA ISO MANGO REFORZADO

Reinforced Shank ISO Standard Metric Machine Straight Tap
Taraud droit machine métrique norme ISO queue renforcée

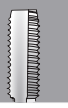
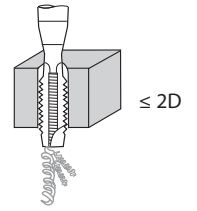
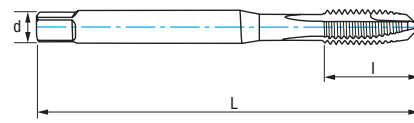

HSSE
5% Co

ISO
529



Tol.
6H



α
 $10^\circ \pm 2$



Aceros
<math><850 \text{ N/mm}^2</math>
Steel / Aciers

Cobre
Copper
Cuivre

Aluminio
Aluminium

M	P	L mm	l mm	d mm	a mm	Z	Nº Art.	€
M3	0,50	48	11	3,15	2,50	3	38180	6,77
M4	0,70	53	13	4,00	3,15	3	38182	6,77
M5	0,80	58	16	5,00	4,00	3	38373	6,77
M6	1,00	66	19	6,30	5,00	3	38185	6,77
M8	1,25	72	22	8,00	6,30	3	38187	9,05
M10	1,50	80	24	10,00	8,00	3	38188	11,51

Línea 33 cm
3109

MACHO RECTO MÁQUINA MÉTRICA ISO MANGO REFORZADO

Reinforced Shank ISO Standard Metric Machine Straight Tap
Taraud droit machine métrique norme ISO queue renforcée

26
cm



ø	M3	M5	M6	M8	M10
Pcs	3	3	3	3	3

Ref. 4995 - Nº Art. 71560: 122,58 €



Ref. **3207**

MACHO RECTO MÁQUINA MÉTRICA NORMA ISO

ISO Standard Metric Machine Straight Tap

Taraud droit machine métrique norme ISO

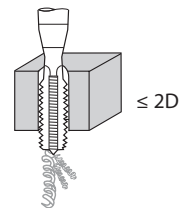
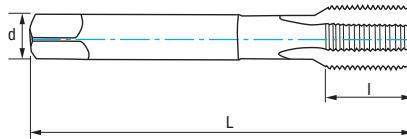

HSS

ISO
529



Tol.
6H



α
 $10^\circ \pm 2$

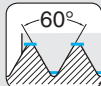

Aceros
<math><850 \text{ N/mm}^2</math>
Steel / Aciers

Cobre
Copper
Cuivre

Aluminio
Aluminium



M	P	L mm	l mm	d mm	a mm	Z	Nº Art.	€
M12	1,75	89	29	9,00	7,10	3	38189	14,78
M14	2,00	95	30	11,20	9,00	3	38190	17,68
M16	2,00	102	32	12,50	10,00	3	38191	21,95
M18	2,50	112	37	14,00	11,20	3	38192	33,05
M20	2,50	112	37	14,00	11,20	3	38193	36,94
M22	2,50	118	38	16,00	12,50	3	38194	42,71
M24	3,00	130	45	18,00	14,00	3	38195	48,25
M27	3,00	135	45	20,00	16,00	3	38196	59,42
M30	3,50	138	48	20,00	16,00	3	38197	88,29

Línea 33 cm
3207

MACHO RECTO MÁQUINA MÉTRICA NORMA ISO

ISO Standard Metric Machine Straight Tap

Taraud droit machine métrique norme ISO

26
cm



ø	M12	M14	M16	M18	M20
Pcs	3	3	3	3	3

Ref. 4995 - Nº Art. 71563: **373,20 €**



Ref. **3157**

MACHO HELICOIDAL MÁQUINA MÉTRICA ISO M. REFORZADO

Reinforced Shank ISO Standard Metric Machine Spiral Tap

Taraud hélicoïdal machine métrique norme ISO queue renforcée

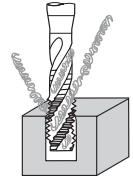
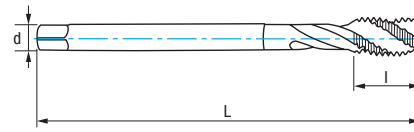

< 2D

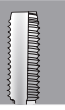

Aceros
<850 N/mm²
Steel / Aciers

Cobre
Copper
Cuivre

Aluminio
Aluminium

M	P	L mm	l mm	d mm	a mm	Z	Nº Art.	€
M3	0,50	48	11	3,15	2,50	3	38198	8,16
M4	0,70	53	13	4,00	3,15	3	38201	8,16
M5	0,80	58	16	5,00	4,00	3	38206	8,16
M6	1,00	66	19	6,30	5,00	3	38209	8,34
M8	1,25	72	22	8,00	6,30	3	38214	9,35
M10	1,50	80	24	10,00	8,00	3	38216	12,05

Línea 33 cm
3157

MACHO HELICOIDAL MÁQUINA MÉTRICA ISO M. REFORZADO

Reinforced Shank ISO Standard Metric Machine Spiral Tap

Taraud hélicoïdal machine métrique norme ISO queue renforcée

26
cm



ø	M3	M5	M6	M8	M10
Pcs	3	3	3	3	3

Ref. 4995 - Nº Art. 70997: 138,19 €



Ref. **3247**

MACHO HELICOIDAL MÁQUINA MÉTRICA NORMA ISO

ISO Standard Metric Machine Spiral Tap

Taraud hélicoïdal machine métrique norme ISO

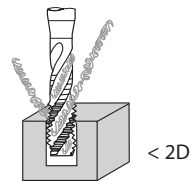
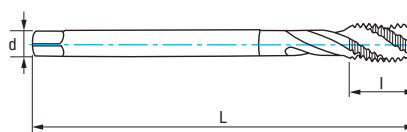

HSS

ISO
529



Tol.
6H

α
12-14°



Aceros
<850 N/mm²
Steel / Aciers

Cobre
Copper
Cuivre

Aluminio
Aluminium



M	P	L mm	l mm	d mm	a mm	Z	Nº Art.	€
M12	1,75	89	29	9,00	7,10	3	38226	15,66
M14	2,00	95	30	11,20	9,00	3	38228	21,41
M16	2,00	102	32	12,50	10,00	3	38229	24,83

Línea 33 cm
3247

MACHO HELICOIDAL MÁQUINA MÉTRICA NORMA ISO

ISO Standard Metric Machine Spiral Tap

Taraud hélicoïdal machine métrique norme ISO



ø	M12	M14	M16
Pcs	3	3	3

Ref. 4995 - Nº Art. 72127: 185,69 €

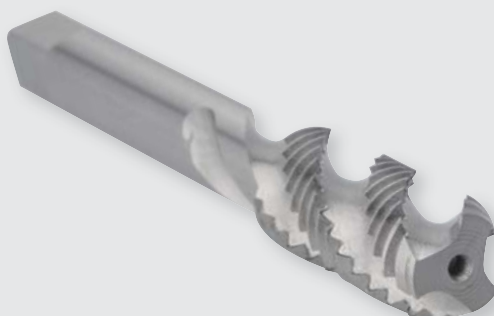

Ref. **3500**

COJINETE MANO MÉTRICA / MÉTRICA FINA

Metric / Metric Fine Hand Die

Filière à main métrique / métrique pas fin



HSS

DIN
223

Tol.
6g

α
10-17°

Chaflán Entrada 1,75h
Chamfer 1,75 Threads
Chanfrein 1,75 filets

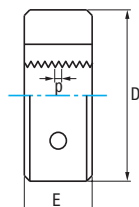

M/MF	P	D mm	E mm	N° Art.	€
M2	0,40	16	5	63191	23,82
M2,5	0,45	16	5	75001	23,82
M3	0,50	20	5	63194	20,17
M3,5	0,60	20	5	63197	23,82
MF4	0,50	20	5	77025	32,77
M4	0,70	20	5	63200	20,17
M4,5	0,75	20	7	77028	22,01
MF5	0,50	20	5	77029	35,19
M5	0,80	20	7	63203	20,17
MF6	0,50	20	7	77034	35,19
MF6	0,75	20	7	77035	31,60
M6	1,00	20	7	63206	20,17
MF7	0,75	25	9	77037	22,27
M7	1,00	25	9	63209	22,01
MF8	0,50	25	9	77038	34,26
MF8	0,75	25	9	77039	34,26
MF8	1,00	25	9	63212	34,26
M8	1,25	25	9	63215	22,01
MF9	1,00	25	9	77041	38,12
M9	1,25	25	9	63218	29,32
MF10	0,75	30	11	77043	53,31
MF10	1,00	30	11	63221	41,91
MF10	1,25	30	11	63224	45,47
M10	1,50	30	11	63227	29,32
MF11	1,00	30	11	77045	52,14
MF11	1,25	30	11	77046	56,86
M11	1,50	30	11	63230	38,49
MF12	1,00	38	10	63233	53,02
MF12	1,25	38	10	63236	53,02
MF12	1,50	38	10	63239	47,40
M12	1,75	38	14	63242	31,15
MF13	1,00	38	10	77049	44,40
MF13	1,50	38	10	77050	46,68
MF14	1,00	38	10	63251	54,40
MF14	1,25	38	10	63254	57,94
MF14	1,50	38	10	63257	49,54
M14	2,00	38	14	63260	31,15
MF15	1,00	38	10	75307	50,49
MF15	1,50	38	10	77053	67,91
MF16	1,00	45	14	63266	73,58
MF16	1,25	45	14	77054	47,63
MF16	1,50	45	14	63269	68,04
M16	2,00	45	18	63272	42,14
MF18	1,00	45	14	77057	76,94
MF18	1,25	45	14	77058	62,27
MF18	1,50	45	14	63278	68,04
MF18	2,00	45	14	63281	76,94
M18	2,50	45	18	63284	42,14
MF20	1,00	45	14	77061	76,60
MF20	1,50	45	14	63287	70,22

M/MF	P	D mm	E mm	N° Art.	€
MF20	2,00	45	14	63290	77,15
M20	2,50	45	18	63293	42,14
MF22	1,00	55	16	77066	104,61
MF22	1,50	55	16	63296	90,02
MF22	2,00	55	16	63299	100,13
M22	2,50	55	22	63302	62,32
MF24	1,00	55	16	77069	100,13
MF24	1,50	55	16	77070	90,02
MF24	2,00	55	16	63308	100,14
M24	3,00	55	22	63311	62,32
MF25	1,00	55	16	77072	134,95
MF25	1,50	55	16	77073	122,34
MF26	1,00	55	16	77075	146,09
MF26	1,50	55	16	77076	123,78
MF27	1,00	65	18	70103	107,36
MF27	1,50	65	18	77656	136,09
MF27	2,00	65	18	77079	148,03
M27	3,00	65	25	63314	93,46
MF28	1,50	65	18	77081	96,91
MF30	1,00	65	18	77082	113,78
MF30	1,50	65	18	77083	136,06
MF30	2,00	65	18	75310	151,96
M30	3,50	65	25	63317	93,46
MF32	1,50	65	18	77085	143,81
MF33	1,50	65	18	77088	136,09
MF33	2,00	65	18	77089	105,52
M33	3,50	65	26	77090	97,14
MF35	1,50	65	18	77093	147,27
MF36	1,50	65	18	75311	139,40
MF36	2,00	65	18	77095	148,19
MF36	3,00	65	25	77096	113,43
M36	4,00	65	25	77097	97,14
M39	4,00	75	30	77103	148,42
MF40	1,50	75	20	77104	219,94
MF40	2,00	75	20	77105	159,32
MF40	3,00	75	30	70104	173,77
MF42	2,00	75	20	77108	236,01
MF42	3,00	75	30	70106	219,35
M42	4,50	75	30	77110	148,42
MF45	1,50	90	22	77112	289,21
MF45	2,00	90	22	77113	244,08
MF45	3,00	90	36	77114	254,64
M45	4,50	90	36	77115	232,73
MF48	1,50	90	22	70107	219,73
MF48	3,00	90	36	35159	230,19
M48	5,00	90	36	77119	232,73
MF50	1,50	90	22	77120	289,21
MF52	1,50	90	22	77121	289,21
M52	5,00	90	36	77124	232,73

Sets
3500

COJINETE MANO MÉTRICA / MÉTRICA FINA

Metric / Metric Fine Hand Die

Filière à main métrique / métrique pas fin



7 Pcs

Cont. Ø	Nº Art.	€
Cojinetes / Dies / Filières DIN 223: M3-M4-M5-M6-M8- M10-M12	56518	163,17

Línea 33 cm
3500

COJINETE MANO MÉTRICA / MÉTRICA FINA

Metric / Metric Fine Hand Die

Filière à main métrique / métrique pas fin



Ø	M4	M5	M6	M8	M10	M12
Pcs	2	2	2	2	2	2

Ref. 4995 - Nº Art. 71001: 285,99 €



Ref. **3005**

TERRAJA MONOBLOCK METAL

METAL Monoblock Die
Filière monoblock MÉTAL



HSS	DIN 223	Mano Hand Main	Tol. 6g	α 10-17°	Con Guía Guided Avec Guide
------------	---------	-----------------------	---------	-----------------	-----------------------------------

M	P	D mm	Nº Art.	€
M3	0,50	20	25226	20,51
M4	0,70	20	25227	20,51
M5	0,80	20	25228	20,51
M6	1,00	20	25229	20,90
M8	1,25	25	25231	22,02
M10	1,50	30	25233	29,05
M12	1,75	38	25581	30,85

Display
43



Ref. 3005	Ø	M-4	M-5	M-6	M-8	M-10	M-12
Pcs		2	2	2	2	2	2

Ref. 4995 - Nº Art. 32964: 287,69 €

Ref. **3006**

JUEGO TERRAJAS MONOBLOCK Y MACHOS MANO

Monoblock Die & Hand Tap Set
Jeu filières monoblock & tarauds à main

30 Pcs

Cont.	Nº Art.	€
Juegos Machos Tap Sets / Jeux Tarauds M3 - M4 - M5 - M6 - M8 - M10 - M12	78141	160,75
Terrajas / Dies / Filières Monoblock Ref. 3005 M3 - M4 - M5 - M6 - M8 - M10 - M12		
Gira-Machos Tap-Wrench / Porte-Tarauds M1 - M12		
Galga Gauge / Gabarit 1 pc		



Ref. **3536**

COJINETE MANO MÉTRICA / MÉTRICA FINA INOX

Stainless Metric / Metric Fine Hand Die

Filière à main métrique / métrique pas fin inox



HSSE
5% Co

DIN
22568

Tol.
6g

Métrica

α
20°



Aceros
Steels
Aciers

INOX
Stainless Steel
Acier INOX

Chafilán Entrada 2,25h
Chamfer 2,25 Threads
Chanfrein 2,25 filets

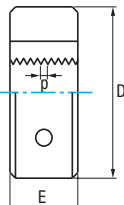

M	P	D mm	E mm	N° Art.	€
M3	0,50	20	5	34255	22,18
M4	0,70	20	5	34256	22,18
M5	0,80	20	7	34257	22,18
M6	1,00	20	7	34258	22,39
M7	1,00	25	9	55515	24,11
M8	1,25	25	9	34259	24,11
MF10	0,75	30	11	81370	39,13
MF10	1,00	30	11	81371	34,32
MF10	1,25	30	11	81372	32,30
M10	1,50	30	11	34260	32,25
MF12	1,00	38	10	81373	47,11
MF12	1,25	38	10	81374	43,16
MF12	1,50	38	10	81375	43,16
M12	1,75	38	14	34261	41,69
MF14	1,00	38	10	81376	48,02
MF14	1,50	38	10	81377	43,84
M14	2,00	38	14	34262	41,69
MF15	1,00	38	10	81378	47,93
MF16	1,00	45	14	81379	87,29

M	P	D mm	E mm	N° Art.	€
MF16	1,50	45	14	81380	78,79
M16	2,00	45	18	34263	57,81
MF17	1,00	45	14	81381	69,82
MF18	1,00	45	14	81382	67,10
MF18	1,50	45	14	81383	60,57
MF18	2,00	45	14	81384	67,21
M18	2,50	45	18	34264	57,81
MF20	1,00	45	14	81385	67,10
MF20	1,50	45	14	81386	60,57
MF20	2,00	45	14	81387	67,10
M20	2,50	45	18	34265	57,81
MF22	1,00	55	16	81388	125,37
MF22	1,50	55	16	81389	114,49
MF22	2,00	55	16	81390	125,37
M22	2,50	55	22	81391	109,13
MF24	1,50	55	16	81392	114,49
M24	3,00	55	22	81393	109,13
M27	3,00	65	25	81394	168,92
M30	3,50	65	25	81395	176,09
M33	3,50	65	25	83117	211,35



Set 7 Pcs

Cont.	N° Art.	€
Cojinetes / Dies / Filières DIN 223: M3-M4-M5-M6-M8- M10-M12	76494	186,97

Línea 33 cm
3536

COJINETE MANO MÉTRICA INOX

STAINLESS Metric Hand Die

Filière à main métrique INOX



ø	M4	M5	M6	M8	M10	M12
Pcs	2	2	2	2	2	2

Ref. 4995 - N° Art. 71005: 329,59 €

Ref. **3510**

COJINETE MANO MÉTRICA ISO

ISO Metric Hand Die
Filière à main métrique ISO



HSS	ISO 529	Ajustable BS 1127 A Adjustable	α 10-17°	Forma A Form	Tol. 6g
-----	---------	--------------------------------------	--------------------	--------------------	------------

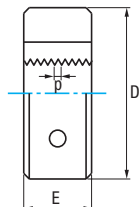

M	P	D mm	E mm	N° Art.	€
M3	0,50	25,4	9,5	38230	7,78
M4	0,70	25,4	9,5	38231	7,78
M5	0,80	25,4	9,5	38232	7,78
M6	1,00	25,4	9,5	38233	7,78
M7	1,00	25,4	9,5	38234	9,12
M8	1,25	25,4	9,5	38235	8,22
M10	1,50	25,4	9,5	38237	10,47
M12	1,75	25,4	9,5	38238	10,47

M	P	D mm	E mm	N° Art.	€
M8	1,25	38,1	12,7	38239	24,35
M10	1,50	38,1	12,7	38240	25,37
M12	1,75	38,1	12,7	38242	25,37
M14	2,00	38,1	12,7	38243	25,37
M16	2,00	38,1	12,7	38244	25,37
M18	2,50	38,1	12,7	38245	37,53
M20	2,50	38,1	12,7	38246	37,53

M	P	D mm	E mm	N° Art.	€
M18	2,50	50,8	15,9	38250	45,64
M20	2,50	50,8	15,9	38251	45,64
M22	2,50	50,8	15,9	38252	45,64
M24	3,00	50,8	15,9	38253	47,67

Línea 33 cm
3510

COJINETE MANO MÉTRICA ISO

ISO Metric Hand Die
Filière à main métrique ISO



ø	M4x25,4	M5x25,4	M6x25,4	M8x25,4	M10x25,4	M12x25,4
Pcs	2	2	2	2	2	2

Ref. 4995 - N° Art. 72129: 105,03 €

Ref. **3502**

COJINETE MANO WHITWORTH

Whitworth Hand Die
Filière à main Whitworth



HSS	α 10-17°	W	DIN 223	Chafán Entrada 1,75h Chamfer 1,75 Threads Chanfrein 1,75 Filets
-----	--------------------	---	---------	---

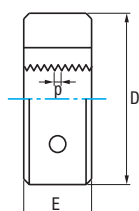

W	Hilos Threads Filets	D mm	E mm	N° Art.	€
W3/32	48	16	5	63344	37,46
W1/8	40	20	5	63329	30,26
W5/32	32	20	7	63356	31,52
W3/16	24	20	7	63341	31,52
W7/32	24	20	7	63365	41,32
W1/4	20	20	7	63323	30,26
W5/16	18	25	9	63350	31,52
W3/8	16	30	11	63335	45,66

W	Hilos Threads Filets	D mm	E mm	N° Art.	€
W7/16	14	30	11	63362	45,66
W1/2	12	38	14	63320	45,66
W9/16	12	38	14	63368	54,68
W5/8	11	45	18	63347	66,42
W3/4	10	45	18	63332	66,42
W7/8	9	55	22	63359	97,67
W1"	8	55	22	63374	97,67
W1" 1/8	7	65	25	63383	153,74

Ref. **3546**

COJINETE MANO BSP (GAS) INOX

Stainless BSP (Gas) Hand Die
Filière à main BSP (Gaz) Inox



HSSE 5% Co	Gas (BSP)	DIN 24231	α 20°		Tol. A	Chafilán Entrada 2,25h Chamfer 2,25 Threads Chanfrein 2,25 filets
Aceros Steels Aciers	INOX Stainless Steel Acier INOX					

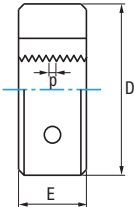

G	Hilos Threads Filets	D mm	E mm	Nº Art.	€
G1/8	28	30	11	81341	43,95
G1/4	19	38	10	81342	43,95
G3/8	19	45	14	81343	59,70
G1/2	14	45	14	81344	59,70
G3/4	14	55	16	81345	117,29
G1"	11	65	18	81346	179,26

Ref. **3506**

COJINETE MANO BSP (GAS)

BSP (Gas) Hand Die
Filière à main BSP (Gaz)



HSS	α 10-17°	Gas (BSP)	DIN 24231	Chafilán Entrada 1,75h Chamfer 1,75 Threads Chanfrein 1,75 filets
------------	--------------------	--------------	--------------	--

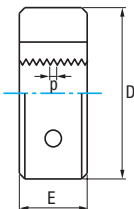

G	Hilos Threads Filets	D mm	E mm	Nº Art.	€
G1/8	28	30	11	63461	39,95
G1/4	19	38	10	63455	39,95
G3/8	19	45	14	63467	51,68
G1/2	14	45	14	63452	51,68
G5/8	14	55	16	75496	78,86
G3/4	14	55	16	63464	107,10
G7/8	14	65	18	76252	112,11
G1"	11	65	18	63470	112,11
G1" 1/8	11	75	20	76202	205,35
G1" 1/4	11	75	20	76210	205,35
G1" 1/2	11	90	22	76224	205,35

Ref. **3191**

GIRA-MACHOS

Tap Wrench
Porte-taraud



DIN
1814



Mod.	Uso Use Usage	L mm	Cuadrado Square / Carré mm	Nº Art.	€
000	M1-M8	125	2,10-4,90	69826	14,28
010	M1-M10	180	2,10-5,50	69828	14,92
015	M1-M12	200	2,10-7,00	69829	16,28
020	M4-M12	280	3,40-7,00	69831	20,82
030	M5-M20	375	4,90-12,00	69832	29,09

Mod.	Uso Use Usage	L mm	Cuadrado Square / Carré mm	Nº Art.	€
040	M11-M27	500	6,20-16,00	69834	46,14
050	M13-M32	750	7,00-20,00	69835	95,47
* 060	M18-M42	870	7,00-28,00	83111	109,27
* 070	M25-M52	1250	16,00-32,00	26694	183,62

* Acero / Steel / Acier

Línea 33 cm
3191

GIRA-MACHOS

Tap Wrench
Porte-taraud



Mod.	000	010	015	020	030
Pcs	2	2	2	2	2

Ref. 4995 - Nº Art. 80556: 190,77 €

Ref. **3912**

GIRA-MACHOS CRIQUÉ

Tap Wrench
Porte-taraud



"T" +
Criqué



Mod.	M	L mm	Cap. mm	Nº Art.	€
01	M3-M10	85	2,4-5,5	25340	21,11
02	M5-M12	100	4,5-8,0	25341	28,68
10	M3-M10	250	2,4-5,5	25342	33,29
20	M5-M12	300	4,5-8,0	25343	39,71

Línea 33 cm
3912

GIRA-MACHOS CRIQUÉ

Tap Wrench
Porte-taraud



Mod.	01	02	10	20
Pcs	2	2	2	2

Ref. 4995 - Nº Art. 72135: 245,56 €

Ref. **9016**

BROCA METAL DURO MATERIALES TEMPLADOS 70 HRC

70 HRC Hardened Materials Solid Carbide Drill Bit
Foret carbure matériaux trempés 70 HRC

New!

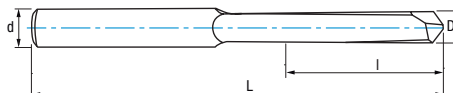

MD / HM
Carbure
Grano UF

IZAR
Std.



HRC
50-70

Tol.
h6

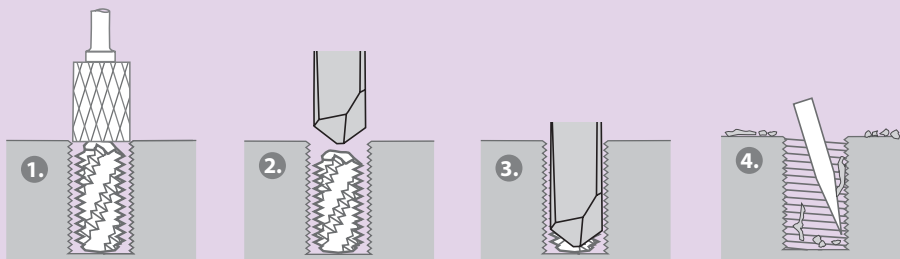

PROCEDIMIENTO PARA QUITAR MACHOS ROTOS:

1. Macho roto

Si sobresale alguna parte del macho roto, alisarla para poder taladrarlo más fácilmente.

2. Centrado de la broca

Colocar la broca sobre el centro del macho, fijando bien tanto la pieza de trabajo como la misma broca.

Sin lubricante, hacer un taladrado inicial de aproximación y retraer la broca rápidamente.

3. Proceso de taladrado

Taladrar a velocidad y avance fijos, y con pausas para evacuar la viruta. Utilizar lubricación.

4. Sustraer el macho roto

Sustraer los restos del macho roto con un buril o instrumento similar.

PROCEDURE FOR REMOVING BROKEN TAPS:

1. Broken Tap

If any part of the broken tap is protruding, grind the surface in order to make it flat.

2. Centering of the Drill

Position the drill bit on the center of the broken tap. Please make sure that both the workpiece and the tap are firmly secured. Make an initial drill approach and retract the drill bit quickly. Don't use any lubrication.

3. Drilling

Drill the hole at a fixed speed and feed, stopping the process occasionally to remove the broken chips. Use lubrication in this step.

4. Chip Removal

The parts of the broken tap can be removed using a scriber or a similar tool.

PROCÉDURE POUR ENLEVER LES TARAUDS CASSÉS:

1. Taraud cassé

Si une partie du taraud dépasse, lissez la surface endommagée du taraud au ras de la pièce pour la percer plus facilement.

2. Centrage du foret

Placez le foret au centre du taraud. Assurez-vous que la pièce et le foret sont correctement centrés. Faites un premier perçage d'approximation, puis rétractez rapidement le foret. Pour cette étape, n'utilisez pas de lubrifiant.

3. Processus de perçage

Percez le trou à vitesse et avance fixes, en arrêtant de temps en temps pour évacuer les copeaux. Utilisez du lubrifiant.

4. Retirer les restes

Les restes peuvent être retirés en utilisant un burin ou similaire.

- Diseño especial para retirar machos rotos.
- Requiere una buena sujeción de pieza y cabezal rígido.
- No válido para extraer machos de laminación.
- Specifically designed for removing broken taps.
- It is recommended to use a proper fixing with an stable chuck.
- Not suitable for forming taps.
- Conception spéciale pour enlever les tarauds cassés.
- Nécessite un bon serrage de la pièce et une tête rigide.
- Non valide pour retirer les tarauds réfoyeurs.

D mm	d mm	L mm	l mm	Macho Tap - Taraud		Nº Art. MD/HM	€
2,00	3,00	38	10	M3	1	58951	34,78
3,00	3,00	38	15	M4 - M5	1	58954	34,78
4,00	4,00	50	20	M6	1	59987	47,84
5,00	5,00	50	25	M8 - M10	1	59989	53,85
6,00	6,00	60	30	M12	1	66145	59,79
7,00	8,00	79	35	M14	1	66399	79,84
8,00	8,00	79	40	M16	1	66407	79,84
9,00	10,00	100	45	M18	1	66408	103,29
10,00	10,00	100	50	M20	1	66409	103,29



Set 5 Pcs

Cont.	Nº Art.	€
2-3-4-5-6 mm	83426	219,50

Ref. **3409**

EXTRACTOR TORNILLOS

Screw Extractor
Extracteur vis



Mod.	P/ Tornillo F/ Screw P/ Vis	P/ Tornillo F/ Screw P/ Vis	D mm	a mm	Nº Art.	€
010	M3-M6	1/8-1/4	2,50	2,70	40639	2,82
020	M6-M8	1/4-5/16	3,00	3,80	40641	2,82
030	M8-M11	5/16-7/16	4,50	4,90	40642	2,94
040	M11-M14	7/16-9/16	6,00	7,00	40644	4,16
050	M15-M18	9/16-3/4	8,00	9,00	40645	6,52
060	M18-M24	3/4-1	11,00	12,00	40647	10,35



Set 5 Pcs

Set P/ Tornillo F/ Screw P/ Vis	P/ Tornillo F/ Screw P/ Vis	Nº Art.	€
M3-M18	1/8-3/4	75905	19,26

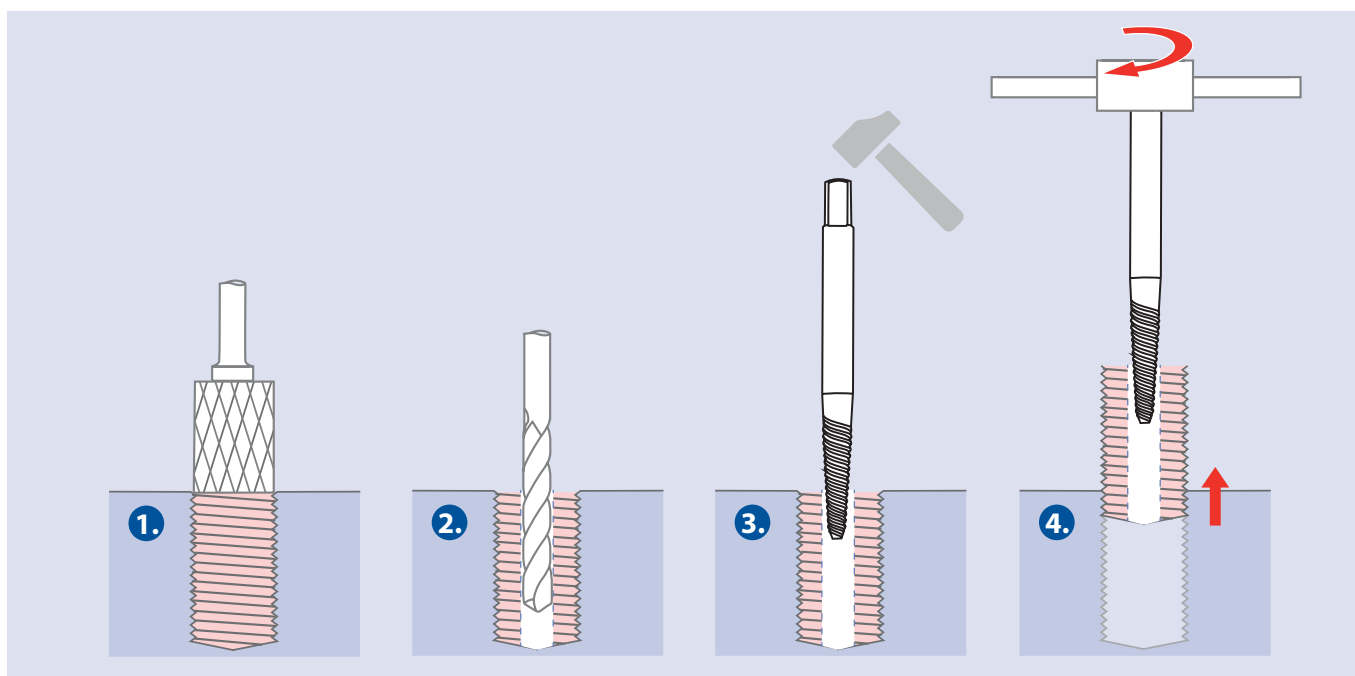

INSTRUCCIONES USO:

1. Limpiar la superficie del tornillo.
2. Taladrar un agujero centrado con broca apropiada.
3. Introducir el extractor asegurándose de que quede fijo.
4. Girar el extractor hacia la izquierda hasta extraer el tornillo.

DIRECTIONS FOR USE:

1. Clean properly the surface of the screw head.
2. Drill a hole on the screw using a suitable drill bit.
3. Introduce the extractor and make sure it gets fixed/locked.
4. Turn left the extractor until the screw gets out.

INSTRUCTIONS D'EMPLOI:

1. Nettoyez correctement la surface de la vis.
2. Percez un trou centré avec un foret approprié.
3. Insérez l'extracteur et assurez-vous qu'il est fixé.
4. Tournez à gauche l'extracteur jusqu'à retirer la vis.

Línea 33 cm
3409

EXTRACTOR TORNILLOS

Screw Extractor
Extracteur vis



Mod.	10	20	30	40	50	60
Pcs	5	5	5	5	5	4

Ref. 4995 - Nº Art. 72139: 137,72 €

Ref. **3181**

PORTA-COJINETES

Die Holder
Porte filières



DIN
225



Mod.	D mm	E mm	L mm	M/MF	W	G	N° Art.	€
000	16	5	160	M1-M2,6	W1/16-W3/32		69792	7,99
010	20	5	200	M3-M4	W1/8-W5/32		69790	8,67
020	20	7	200	M4,5-M6	W3/16-W1/4		69798	8,67
030	25	9	224	M7-M9	W5/16	G1/16	69799	9,95
040	30	11	280	M10-M11	W3/8-W7/16	G1/8	69811	12,34
050	38	14	315	M12-M15	W1/2-W9/16		69813	15,66
060	38	10	315	MF12-MF15		G1/4	69814	15,66
070	45	18	450	M16-M20	W5/8-W3/4		69816	19,38
080	45	14	450	MF16-MF20		G3/8-G1/2	69817	19,38
090	55	22	560	M22-M24	W7/8-W1		69819	26,03
100	55	16	560	MF21-MF26		G5/8-G3/4	69795	24,79
110	65	25	630	M27-M36	W1 1/8 - W1 3/8		69796	36,53
120	65	18	630	MF27-MF36		G7/8-G1	30484	36,53
* 130	75	30	920	M39-M42	W1 1/2 - W1 5/8		32600	113,61
* 140	75	20	920	MF38-MF42		G1 1/8 - G1 1/4	43515	113,61
* 150	90	36	950	M45-M52	W1 3/4 - W2		43516	165,57
* 160	90	22	950	MF45-MF52		G1 1/2	43517	165,57

* Acero / Steel / Acier

Ref. **3184**

PORTA-COJINETES ISO 529

ISO 529 Die Holder
Porte filières ISO 529



DIN
225

D mm	E mm	M	W	N° Art.	€
25,40	9,50	M3-M12	W1/8-W1/2	43317	10,37
38,10	12,70	M8-M20	W5/16-W3/4	43318	15,49
50,80	15,90	M18-M24	W11/16-W1	43319	22,39

Ref. **3900**

GALGA

Pitch Gauge
Jauge



Cap. M	Cap. W	N° Art.	€
0,25-6,00	4G-62G	44612	7,44
0,40-6,00		67641	2,88

Ref. **3405**

JUEGO MACHOS MANO MÉTRICA

Metric Hand Tap Set
Jeu de tarauds à main métrique

Set 29 Pcs

Cont.		Nº Art.	€
Juegos Machos / Tap Sets / Jeux Tarauds	M3-M4-M5-M6-M8-M10-M12	69624	96,27
Brocas / Drill Bits / Forets mm	2,5-3,3-4,2-5,0-6,8-8,5-10,2		
Gira-Machos / Tap-Wrench / Porte-Tarauds	M1-M12		



Ref. **3404**

JUEGO MACHOS MANO PERFIL ROSCA COMPLETA

Whole Thread Profile Hand Tap Set
Jeu de tarauds à main profil filetage complet

Set 15 Pcs

Cont.		Nº Art.	€
Machos / Taps / Tarauds	M3-M4-M5-M6-M8-M10-M12	68214	79,19
Brocas / Drill Bits / Forets mm	2,5-3,3-4,2-5,0-6,8-8,5-10,2		
Gira-Machos / Tap-Wrench / Porte-Tarauds	M1-M12		



Ref. **3406**

JUEGO MACHOS / COJINETES MANO MÉTRICA

Metric Hand Tap & Die Set

Jeu de tarauds et filières à main métrique



Set 33 Pcs

Mod. 0		Nº Art.	€
Juegos Machos Tap Sets / Jeux Tarauds	M3-M4-M5-M6-M8-M10-M12	70527	122,38
Gira-Machos Tap-Wrench / Porte-Tarauds	M1-M12		
Gira-Machos Tap-Wrench / Porte-Tarauds	Criqué M3-M10 Ratchet		
Cojinetes Dies / Filières	M3-M4-M5-M6-M8-M10-M12		
Porta-Cojinetes Die Holder / Porte-Filières	25x9		
Galga Gauge / Gabarit	1 pc		
Destornillador Screwdriver / Tournevis	1 pc		



Set 55 Pcs

Mod. 1		Nº Art.	€
Juegos Machos Tap Sets / Jeux Tarauds	M3-M4-M5-M6-M8-M10-M12- M14-M16-M18-M20	38404	365,99
Gira-Machos Tap-Wrench / Porte-Tarauds	M1-M12, M5-M20		
Gira-Machos Tap-Wrench / Porte-Tarauds	Criqué M3-M10 + M5-M12 Ratchet		
Cojinetes Dies / Filières	M3-M4-M5-M6-M8-M10-M12- M14-M16-M18-M20		
Porta-Cojinetes Die Holder / Porte-Filières	20x5, 20x7, 25x9, 30x11, 38x14, 45x18		
Galga Gauge / Gabarit	1 pc		
Destornillador Screwdriver / Tournevis	1 pc		



Set 45 Pcs

Mod. 2		Nº Art.	€
Juegos Machos Tap Sets / Jeux Tarauds	M3-M4-M5-M6-M8-M10-M12	38981	179,51
Gira-Machos Tap-Wrench / Porte-Tarauds	M1-M10, M4-M12		
Gira-Machos Tap-Wrench / Porte-Tarauds	Criqué M3-M10 Ratchet		
Cojinetes Dies / Filières	M3-M4-M5-M6-M8-M10-M12		
Porta-Cojinetes Die Holder / Porte-Filières	20x5, 20x7, 25x9, 30x11, 38x14		
Galga Gauge / Gabarit	1 pc		
Destornillador Screwdriver / Tournevis	1 pc		
Brocas Drill Bits / Forets mm	2,5-3,3-4,2-5,0-6,8-8,5-10,2		





ACEITES DE CORTE Y REFRIGERANTES

Cutting Oils & Water Soluble Fluids

Huiles de coupe et lubrifiants

ACEITES DE CORTE

Aceite de corte de uso general de alta gama, formulado a base de aceites vegetales y libre de cloruros. Para aplicaciones de corte en general (taladrado, roscado, fresado, torneado, etc.)

Cutting Oils

High-end general purpose cutting oil, formulated from vegetable oils and chloride-free. For general cutting applications (drilling, threading, milling, turning, etc.)

Huiles de coupe

Huile de coupe à usage général haut de gamme, formulée à base d'huiles végétales et sans chlorures. Pour des applications de coupe en général (perçage, taraudage, fraisage, tournage, etc.)

REFRIGERANTES - TALADRINA

Aceite emulsionable altamente concentrado libre de cloruros, aminas secundarias y / o nitritos

Water Soluble Fluids

Highly concentrated emulsifiable oil free of chlorides, secondary amines and/or nitrites

Lubrifiants

Huile émulsifiable hautement concentrée, exempte de chlorures, d'amines secondaires et/ou de nitrites



ACEITES DE CORTE - Cutting Oils - Huiles de coupe

UNI

New!

Universal

Viscosidad a 40°C
Viscosity / Viscosité:
37 cSt

No
Soluble

- * Disponible Ficha Técnica
- * Data Sheet available
- * Fiche technique disponible

APLICACIÓN:

Para aplicaciones de uso general y universal (UNI) en todos los metales ferrosos.

APPLICATION:

For general purpose and universal (UNI) applications on all ferrous metals.

APPLICATION:

Pour des applications à usage général et universel (UNI) sur tous les métaux ferreux.



Cont. 250 ml
Nº Art. 53898
€ 8,34

Cont. 500 ml
Nº Art. 53901
€ 11,27

Cont. 1L
Nº Art. 53903
€ 25,79

Cont. 5L
Nº Art. 53904
€ 90,13

Cont. 10L
Nº Art. 53906
€ 165,38

Cont. 25L
Nº Art. 53907
€ 324,88

INOX

New!

Heavy Duty

VISCOSIDAD EXTRA !
Extra Viscosity!
Viscosité supplémentaire !

Viscosidad a 40°C
Viscosity / Viscosité:
173 cSt

No
Soluble

- * Disponible Ficha Técnica
- * Data Sheet available
- * Fiche technique disponible

APLICACIÓN:

Para aplicaciones de mecanizado pesado (Heavy Duty) en todos los metales ferrosos y para un rendimiento mejorado en aceros inoxidable (INOX).

APPLICATION:

For heavy duty machining applications on all ferrous metals and for improved performance on stainless steels (STAINLESS).

APPLICATION:

Pour des applications d'usinage lourd (Heavy Duty) sur tous les métaux ferreux et pour améliorer les performances sur les aciers inoxydables (INOX).



Cont. 250 ml
Nº Art. 53928
€ 12,79

Cont. 500 ml
Nº Art. 53934
€ 22,79

Cont. 1L
Nº Art. 53936
€ 40,04

Cont. 5L
Nº Art. 53937
€ 143,71

Cont. 10L
Nº Art. 53940
€ 273,99

Cont. 25L
Nº Art. 53942
€ 593,66

ALU

New!

Non Ferrous

Viscosidad a 40°C
Viscosity / Viscosité:
4,20 cSt

No
Soluble

- * Disponible Ficha Técnica
- * Data Sheet available
- * Fiche technique disponible

APLICACIÓN:

Especial para aplicaciones en todos los metales no ferrosos como aluminio (ALU), cobre, latón, bronce, zinc

APPLICATION:

Specially for applications on all non-ferrous metals such as aluminium (ALU), copper, brass, bronze, zinc, etc.

APPLICATION:

Spécialement indiqué pour les applications sur tous les métaux non ferreux, tels que l'aluminium (ALU), le cuivre, le laiton, le bronze, le zinc, etc.



Cont.	250 ml
Nº Art.	53943
€	11,54



Cont.	500 ml
Nº Art.	53946
€	18,83



Cont.	1L
Nº Art.	53948
€	31,53



Cont.	5L
Nº Art.	53949
€	116,67

New!

AEROSOL - Aerosol - Aérosol

2 Cánulas / 2 Actuators / 2 Canules



Chorro líquido
Liquid jet
Jet liquide



Spray

Cont.	400ml
Nº Art.	53900
€	14,35

Para aplicaciones de uso general en todos los metales ferrosos

For general purpose applications on all ferrous metals

Pour des applications à usage général sur tous les métaux ferreux



12 UNI

Nº Art.	€
53926	163,63

Box Price!

New!

DISPLAYS



9x250ml
UNI

Nº Art.	€
13929	71,28

Set Price!



UNI+INOX+ALU
3+3+3x250ml
MIXTO

Nº Art.	€
13930	93,09

Set Price!



6x400ml
AEROSOL

Nº Art.	€
13912	81,82

Set Price!

UNI
Universal



UNI INOX ALU
Universal Heavy Duty Non Ferrous



UNI
Universal



New!

PASTA DE CORTE - Cutting Paste - Pâte de coupe

Pasta con propiedades lubricantes extremas. La pasta se asienta en las aristas de corte y se licua durante la operación de corte.

Ideal para todas las operaciones como roscado, taladrado y fresado de materiales difíciles de cortar como acero inoxidable, acero Cr-Ni, titanio, acero al manganeso, etc.

Paste with extreme lubricating properties. The paste settles on the cutting edges and liquefies during the cutting operation.

Ideal for all operations such as the threading, drilling and milling of difficult-to-cut materials such as stainless steel, Cr-Ni steel, titanium, manganese steel, etc.

Pâte aux propriétés lubrifiantes extrêmes. La pâte se dépose sur les bords de coupe et se liquéfie pendant l'opération de coupe.

Idéale pour toutes les opérations telles que le taraudage, le perçage et le fraisage de matériaux difficiles à couper comme l'acier inoxydable, l'acier Cr-Ni, le titane, l'acier au manganèse, etc.



Cont.	250ml
Nº Art.	53954
€	15,75



Cont.	750ml
Nº Art.	53956
€	26,24



Sumerja la herramienta de corte en la pasta para obtener resultados optimizados

Dip the cutting tool into the paste for optimised results

Trempez l'outil de coupe dans la pâte pour des résultats optimisés

New!

CERA DE CORTE - Cutting Wax - Cire de coupe

Cera en barra de alta gama para refrigerante y lubricación de operaciones de corte en metales no ferrosos como aluminio, cobre, latón, etc. Libre de cloruros, sin humos o vapores nocivos.

Para todas las máquinas de hoja de sierra circular o sierra de cinta sin suministro de refrigerante. También apto para fresado, roscado, escariado, taladrado, torneado, etc.

High-end wax in a bar for the cooling and lubrication of cutting operations on non-ferrous metals such as aluminium, copper, brass, etc. Chloride free, no harmful fumes or vapours.

For all circular or band saw blade machines without coolant supply. Also suitable for milling, threading, reaming, drilling, turning, etc.

Cire en barre haut de gamme pour le refroidissement et la lubrification des opérations de coupe sur les métaux non ferreux tels que l'aluminium, le cuivre, le laiton, etc. Sans chlorures, sans fumées ni vapeurs nocives.

Pour toutes les machines à lame de scie circulaire ou à ruban sans alimentation en réfrigérant. Convient également pour le fraisage, taraudage, alésage, perçage, tournage, etc.



Cont.	300ml
Nº Art.	53957
€	27,43



Para aplicar la cera, sostenga brevemente la barra de cera contra la sierra giratoria. Repita cada 10-20 ciclos de aserrado

To apply the wax, briefly hold the wax bar against the rotary saw. Repeat every 10-20 sawing cycles

Pour appliquer la cire, maintenez brièvement la barre de cire contre la scie rotative. Répétez tous les 10 à 20 cycles de sciage

REFRIGERANTES - TALADRINA

Water Soluble Fluids - Lubrificants

STD

New!

Standard

Emulsión semisintética, transparente a semitransparente. Muy alta estabilidad ante los microorganismos. Apto para operaciones de rectificado. Concentración del 4-7% en función de la aplicación.

Semi-synthetic emulsion, transparent to semi-transparent. Very high stability to micro-organisms. Suitable for grinding operations. Concentration 4-7% depending on the application.

Émulsion semi-synthétique, transparente à semi-transparente. Très grande stabilité face aux microorganismes. Convient pour les opérations de meulage. Concentration de 4-7 % selon l'application.



 **Índice Refractómetro**
Refractometer Index
1,60 Índice de réfractomètre

- * Disponible Ficha Técnica
- * Data Sheet available
- * Fiche technique disponible

STANDARD

Cont.	5L
Nº Art.	53958
€	86,78

TOP

New!

Top Line

Emulsión de color blanco lechoso. Para aplicaciones de alto rendimiento en aceros, materiales no ferrosos y aluminio. Concentración 6-10% en función de la aplicación.

Milky white emulsion. For high performance applications on steels, non-ferrous materials and aluminium. Concentration 6-10% depending on application.

Émulsion blanche laiteuse. Pour des applications de haute performance sur les aciers, les matériaux non ferreux et l'aluminium. Concentration de 6-10 % selon l'application.



 **Índice Refractómetro**
Refractometer Index
1,20 Índice de réfractomètre

- * Disponible Ficha Técnica
- * Data Sheet available
- * Fiche technique disponible

TOP LINE

Cont.	5L
Nº Art.	53959
€	101,84

REPARADORES ROSCAS

Thread Repairs

Filets rapportés

Descripción

Desgaste, corrosión, excesiva torsión al ajustar el tornillo... son algunas de las causas que llevan a dañar una rosca sin posibilidad de reparación.

La gama de reparadores de roscas IZARCOIL permite reparar dichas roscas dañadas de manera rápida y económica.

Unos reparadores de acero de gran calidad, para crear una rosca resistente a la temperatura y la corrosión.

Ventajas

- Instalación rápida y sencilla
- Resistente al desgaste y a la tensión
- Resistente a la corrosión y termoestable

Ejemplos de aplicaciones

- Refuerzo para roscar materiales con una reducida resistencia (p.e. aleaciones de aluminio y aleaciones de magnesio)
- Ingeniería mecánica
- Ingeniería de automoción y electricidad

Description

Wear, corrosion or excessive screw tightening torque... are some of the reasons that lead to threads getting damaged beyond repair.

IZARCOIL thread repair range enables worn and damaged threads to be repaired quickly and at low cost.

In high-quality steel for a good thread, resistant to temperature and corrosion.

Advantages

- Fast and easy to install
- Stress resistant and wear-free
- Corrosion resistant and thermostable

Examples of Applications

- Thread reinforcement for materials with low shearing strength (e.g. aluminium or magnesium alloys)
- Mechanical engineering
- Automotive and electrical engineering

Description

Usure et trop de pression dans la fixation de la vis son des raisons pour endommager un filetage sans possibilité de réparation.

La gamme de filets rapportés IZARCOIL vous permet de réparer les filets endommagés rapidement et d'une façon économique.

Filets rapportés en aciers haute qualité pour avoir un filetage résistant à la température et à l'usure.

Avantages

- Installation rapide et simple
- Résistant à l'usure et a la tension
- Résistant aux variations de température

Exemples d'applications

- Soutien pour fileter aciers avec faible resistances (alliage aluminium et magnesium).
- Ingénierie mécanique
- Ingénierie auto et électricité

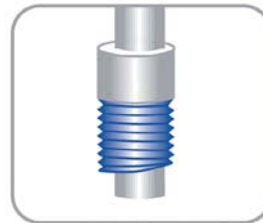

Uso

- 1- Taladrar la rosca dañada con una broca
- 2- Roscar con un macho IZARCOIL
- 3- Biselar el diámetro exterior a 90° y retirar la rebaba
- 4- Insertar el reparador de roscas con la ayuda del vástago
- 5- En caso de agujeros pasantes, usar un rompedor para la muesca

Use

- 1- Drill the thread with a Drill Bit
- 2- Thread with an IZARCOIL tap
- 3- Bevel the external diameter at 90° and remove the burr
- 4- Insert the thread repair using the fitting tool
- 5- In case of through holes, use a pin-breaker for the notch

Emploi

- 1- Percer le filet endommagé avec un foret
- 2- Tarauder avec un taraud IZARCOIL
- 3- Chanfreiner le diamètre extérieur à 90° et retirer les copeaux
- 4- Insérer le réparateur de filets avec l'aide du guide
- 5- Pour trous débouchants, employer un brise-copeaux



Ref. **3300**

INSERTO REPARACIÓN ROSCAS

Thread Repair Insert
Filet rapportés



INOX
304

M/MF

Aceros
Steels
Aciers

Aleaciones Alum. Alloys / Alliages
Aleaciones Mg Alloys / Alliages

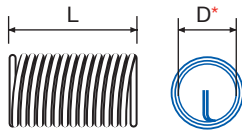

*D = M (aprox.)

M	P	📦	L = 1xD		L = 1,5xD		L = 2xD		L = 2,5xD		L = 3x0D	
			Nº Art.	€ 1 ud.	Nº Art.	€ 1 ud.	Nº Art.	€ 1 ud.	Nº Art.	€ 1 ud.	Nº Art.	€ 1 ud.
M3	0,50	25	56287	0,20	56288	0,20	56289	0,22	56291	0,25	56292	0,35
M4	0,70	25	56293	0,20	56294	0,20	56297	0,22	56299	0,25	56300	0,32
M5	0,80	25	56302	0,22	56303	0,20	56304	0,25	56306	0,31	56309	0,39
M6+ *	1,00	25	56310	0,22	56311	0,20	56312	0,25	56313	0,31	56315	0,46
New! M6- *	1,00	25	14857	0,22	14859	0,20	14863	0,25	14865	0,31	14866	0,46
M7	1,00	25	56316	0,23	56318	0,28	56319	0,31	56320	0,36	56321	0,55
M8	1,00	25	56322	0,25	56324	0,28	56325	0,35	56326	0,42	56327	0,58
M8	1,25	25	56332	0,23	56333	0,25	56334	0,33	56336	0,41	56337	0,55
M9	1,25	25	56339	0,35	56340	0,41	56341	0,48	56342	0,50	56343	0,66
MF10	1,00	25	56344	0,28	56345	0,33	56346	0,38	56347	0,48	56348	0,64
MF10	1,25	25	56349	0,28	56351	0,33	56352	0,38	56353	0,48	56354	0,64
M10	1,50	25	56355	0,28	56357	0,33	56360	0,38	56361	0,48	56362	0,64
M11	1,50	25	56363	0,42	56364	0,58	56365	0,61	56366	0,77	56367	0,94
MF12	1,00	25	56369	0,36	56371	0,53	56372	0,60	56373	0,71	56374	0,94
MF12	1,25	25	56375	0,36	56377	0,53	56378	0,60	56379	0,71	56381	0,94
MF12	1,50	25	56384	0,36	56385	0,53	56387	0,60	56388	0,71	56389	0,94
M12	1,75	25	56390	0,36	56391	0,53	56392	0,60	56393	0,71	56394	0,94
MF14	1,00	10	56395	0,80	56396	0,82	56397	0,94	56399	1,14	56400	1,62
MF14	1,25	10	56401	0,67	56402	0,75	56403	0,80	56404	0,94	56405	1,25
MF14	1,50	10	56406	0,67	56407	0,75	56408	0,80	56409	0,94	56410	1,25
M14	2,00	10	58844	0,67	58845	0,75	58846	0,80	58847	0,95	58848	1,25
MF16	1,50	10	56411	0,89	56412	0,93	56413	1,16	56414	1,26	56416	1,62
M16	2,00	10	56417	0,89	56419	0,93	56420	1,16	56422	1,26	56423	1,62
MF18	2,00	10	56425	1,29	56427	1,51	56430	2,04	56431	2,32	56433	2,99
M18	2,50	10	56434	1,29	56436	1,51	56439	2,04	56440	2,32	56442	2,99
M20	2,50	10	67788	1,63	67790	2,04	67792	2,59	67794	2,95	70628	3,45
M22	2,50	10	56445	1,64	56446	2,04	56448	2,60	56451	2,97	56452	3,92
MF24	2,00	10	56454	2,04	56457	2,16	56458	2,74	56460	3,58	56463	4,18
M24	3,00	10	56464	2,04	56466	2,16	56467	2,74	56473	3,58	56476	4,18

* M6+ → ø7,6 - ø7,7

* M6- → ø7,3 - ø7,4

Ref. **3305**

MACHO PARA INSERTO REPARACIÓN ROSCAS

Thread Repair Insert Tap
Taraud filet rapportés



IZARCOIL

HSS

M/MF

Aceros
Steels
Aciers

Aleaciones Alum. Alloys / Alliages
Aleaciones Mg Alloys / Alliages



M	P	D mm	d mm	L mm	l mm	a mm	Z	Nº Art.	€	D Broca Drill Bit / Foret mm
M3	0,50	3,65	4,00	53	13	3,15	3	56615	7,82	3,20
M4	0,70	4,91	5,00	58	16	4,00	3	56617	8,46	4,20
M5	0,80	6,04	6,30	66	19	5,00	3	56620	8,59	5,20
M6	1,00	7,30	8,00	72	22	6,30	3	56622	8,59	6,30
M7	1,00	8,30	9,00	72	22	7,10	3	56623	12,00	7,30
M8	1,00	9,30	10,00	80	24	8,00	3	56628	12,00	8,30
M8	1,25	9,62	10,00	80	24	8,00	3	56626	11,20	8,30
M9	1,25	10,60	8,00	85	25	6,30	3	56629	14,69	9,40
MF10	1,00	11,30	8,00	85	25	6,30	3	56638	14,69	10,30
MF10	1,25	11,62	8,00	85	25	6,30	3	56634	14,69	10,30
M10	1,50	11,95	9,00	89	29	7,10	3	56632	14,69	10,40
M11	1,50	12,95	9,00	89	29	7,10	3	56640	16,62	11,50
MF12	1,00	13,30	11,20	95	30	9,00	3	56646	20,30	12,30
MF12	1,25	13,62	11,20	95	30	9,00	3	56648	20,30	12,30
MF12	1,50	13,95	11,20	95	30	9,00	3	56647	20,30	12,50
M12	1,75	14,27	11,20	95	30	9,00	3	56644	15,76	12,50
MF14	1,00	15,30	12,50	102	32	10,00	3	56650	23,11	14,30
MF14	1,25	15,62	12,50	102	32	10,00	3	56652	23,11	14,30
MF14	1,50	15,95	12,50	102	32	10,00	3	56651	23,11	14,50
M14	2,00	16,70	12,50	102	32	10,00	4	58849	23,11	14,50
MF16	1,50	18,00	14,00	104	29	11,20	4	56654	27,66	16,50
M16	2,00	18,60	14,00	112	37	11,20	4	56653	27,66	16,50
MF18	2,00	20,60	14,00	104	29	11,20	4	56657	35,02	18,50
M18	2,50	21,30	16,00	118	38	12,50	4	56656	35,02	18,75
M20	2,50	23,32	16,00	118	38	12,50	4	72852	39,65	20,75
M22	2,50	25,30	18,00	130	45	14,00	4	56658	44,29	23,00
MF24	2,00	26,60	20,00	127	37	16,00	4	56660	55,99	24,50
M24	3,00	27,90	20,00	138	48	16,00	4	56659	55,99	25,00

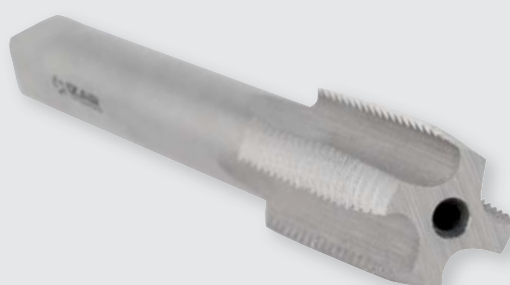

Ref. **3303**

INSERTADOR

Fitting Tool
Appareil de Pose



M	L mm	D mm		N° Art.	€
M3	132	2,20	1	70226	10,01
M4	132	3,00	1	66774	10,01
M5	132	4,00	1	66775	10,01
M6	132	4,90	1	66776	10,01
M8	132	6,50	1	66777	11,35
M10	132	7,00	1	66778	11,35
M12	132	9,50	1	66779	14,10
M14	132	10,00	1	66780	16,61
M16	132	12,75	1	79464	17,76
M18	132	14,90	1	79466	17,76
M20	132	15,95	1	79467	17,76
M22	132	17,95	1	83203	19,97
M24	132	20,00	1	79468	22,19

Ref. **3307**

ROMPE ARRASTRES

Pin-Breaker
Rupteur



M	L mm	D mm		N° Art.	€
M3	100	2,20	1	70238	4,29
M4	100	3,00	1	66781	4,29
M5	100	4,00	1	66782	4,29
M6	100	4,90	1	66783	4,29
M8	100	6,50	1	66784	4,70
M10	100	7,00	1	66785	4,70
M12	100	9,50	1	66786	5,64
M14	100	10,00	1	66787	7,51
M16	100	12,75	1	79470	8,03
M18	100	14,90	1	79476	8,03
M20	100	15,95	1	79477	8,03
M22	100	17,95	1	83205	9,04
M24	100	20,00	1	79478	10,03



Ref. **3310**

SET REPARACIÓN ROSCAS

Thread Repair Set
Set filet rapportés



M

Aceros
Steels
Aciers

Aleaciones Alum. Alloys / Alliages
Aleaciones Mg Alloys / Alliages

Set 95 Pcs

Cont. M5-M12			Nº Art.	€
Insertos Inserts Rapportes	INOX 304	M5 0,80 5 pcs 1xD + 5 pcs 1,5xD + 5 pcs 2,5XD M6 1,00 5 pcs 1xD + 5 pcs 1,5xD + 5 pcs 2,5XD M8 1,25 5 pcs 1xD + 5 pcs 1,5xD + 5 pcs 2,5XD M10 1,50 5 pcs 1xD + 5 pcs 1,5xD + 5 pcs 2,5XD M12 1,75 5 pcs 1xD + 5 pcs 1,5xD + 5 pcs 2,5XD	56481	252,07
Brocas Drill Bits Forets (D mm)	HSS	5,20 - 6,30 - 8,30 - 10,40 - 12,50		
Machos Taps Tarauds (D mm)	HSS	6,04 - 7,30 - 9,62 - 11,95 - 14,27		
Insertadores Fitting Tools Appareils de pose (D mm)		4,00 - 4,50 - 6,25 - 7,20 - 9,50		
Rompe arrastres Pin-Breakers Rupteurs (D mm)		4,00 - 4,50 - 6,25 - 7,20 - 9,50		

Ref. **3311**

SET REPARACIÓN ROSCAS BUJÍAS

Spark Plug Thread Repair Set
Set filet rapportés bougies



M/MF



Aceros
Steels
Aciers

Aleaciones Alum. Alloys / Alliages
Aleaciones Mg Alloys / Alliages

Set 94 Pcs

Cont. M6-M14			Nº Art.	€
Insertos Inserts Rapportes	INOX 304	M6 1,00 5 pcs 1xD + 5 pcs 1,5xD + 5 pcs 2,5XD M8 1,25 5 pcs 1xD + 5 pcs 1,5xD + 5 pcs 2,5XD M10 1,50 5 pcs 1xD + 5 pcs 1,5xD + 5 pcs 2,5XD M12 1,75 5 pcs 1xD + 5 pcs 1,5xD + 5 pcs 2,5XD MF14 1,25 5 pcs 1xD + 5 pcs 1,5xD + 5 pcs 2,5XD	56482	290,47
Brocas Drill Bits Forets (D mm)	HSS	6,30 - 8,30 - 10,40 - 12,50		
Machos Taps Tarauds (D mm)	HSS	7,30 - 9,62 - 11,95 - 14,27 - 15,60		
Insertadores Fitting Tools Appareils de pose (D mm)		4,50 - 6,25 - 7,20 - 9,50 - 12,90		
Rompe arrastres Pin-Breakers Rupteurs (D mm)		4,50 - 6,25 - 7,20 - 9,50 - 12,90		

Ref. **3312**

SET REPARACIÓN ROSCAS COMPLETO

Complete Thread Repair Set
Set filet rapportés complet



Aceros
Steels
Aciers

Aleaciones Alum. Alloys / Alliages
Aleaciones Mg Alloys / Alliages

Set 19 Pcs

New!

M	P	Insertos Inserts Rapportés	INOX 304	Brocas Drill Bits Forets (D mm)	HSS	Machos Taps Tarauds (D mm)	HSS	Insertadores Fitting Tools Appareils de pose (D mm)	Rompe arrastres Pin-Breakers Rupteurs (D mm)	Nº Art.	€
M3	0,50	5 pcs 1xD + 5 pcs 1,5xD + 5 pcs 2,5xD		3,20		3,65		2,20	2,20	60330	35,77
M4	0,70	5 pcs 1xD + 5 pcs 1,5xD + 5 pcs 2,5xD		4,20		4,91		3,00	3,00	56484	35,77
M5	0,80	5 pcs 1xD + 5 pcs 1,5xD + 5 pcs 2,5xD		5,20		6,04		4,00	4,00	56487	35,59
M6	1,00	5 pcs 1xD + 5 pcs 1,5xD + 5 pcs 2,5xD		6,30		7,30		4,90	4,90	56488	38,32
M7	1,00	5 pcs 1xD + 5 pcs 1,5xD + 5 pcs 2,5xD		7,30		8,30		4,90	4,90	67804	46,64
MF8	1,00	5 pcs 1xD + 5 pcs 1,5xD + 5 pcs 2,5xD		8,30		9,30		6,50	6,50	56497	46,64
M8	1,25	5 pcs 1xD + 5 pcs 1,5xD + 5 pcs 2,5xD		8,30		9,62		6,50	6,50	56490	46,64
MF10	1,00	5 pcs 1xD + 5 pcs 1,5xD + 5 pcs 2,5xD		10,30		11,30		7,00	7,00	12675	52,18
MF10	1,25	5 pcs 1xD + 5 pcs 1,5xD + 5 pcs 2,5xD		10,30		11,62		7,00	7,00	56500	52,18
M10	1,50	5 pcs 1xD + 5 pcs 1,5xD + 5 pcs 2,5xD		10,40		11,95		7,00	7,00	56493	52,18
MF12	1,00	5 pcs 1xD + 5 pcs 1,5xD + 5 pcs 2,5xD		12,30		13,30		9,50	9,50	57967	59,85
M12	1,50	5 pcs 1xD + 5 pcs 1,5xD + 5 pcs 2,5xD		12,50		13,95		9,50	9,50	57964	59,85
M12	1,75	5 pcs 1xD + 5 pcs 1,5xD + 5 pcs 2,5xD		12,50		14,27		9,50	9,50	56496	59,85
MF14	1,25	5 pcs 1xD + 5 pcs 1,5xD + 5 pcs 2,5xD		*14,30		15,62		11,50	11,50	57973	60,80
M14	2,00	5 pcs 1xD + 5 pcs 1,5xD + 5 pcs 2,5xD		*14,50		16,60		10,50	10,00	57970	68,79

* **Diámetro de broca correspondiente. Broca no incluida**
Corresponding drill bit diameter. Drill bit not included
Diamètre de foret correspondant. Foret non inclus

FRESAS ROTATIVAS

Rotary Burrs

Fraises limes rotatives

Ref. **9260**

FRESA ROTATIVA MD ZYA-S

ZYA-S HM Rotary Burr

Fraise lime rotative carbure ZYA-S



**MD
HM**
Carbure

**MD/HM
+**
ALTIM

**Norma
ZYA-S**
Norm

**Tipo
B**
Type

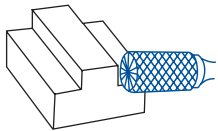
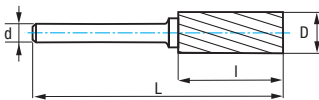

1
MATERIALES NO FERROSOS
Non-Ferrous Materials
Matériaux non ferreux



3
USO GENERAL
General Purpose
Utilisation Générale



4
VIRUTA CORTA
Short Chipping
Copeaux Courts



6
MATERIALES DUROS
Hard Materials
Matériaux Durs

D mm	d mm	L mm	l mm	Dentado Teeth / Denture 1		Dentado Teeth / Denture 1 ALTIM		Dentado Teeth / Denture 3		Dentado Teeth / Denture 4		Dentado Teeth / Denture 6		Dentado Teeth / Denture 6 ALTIM	
				Nº Art.	€	Nº Art.	€	Nº Art.	€	Nº Art.	€	Nº Art.	€	Nº Art.	€
3,00	3,00	38,00	14,00	55677	10,73			44072	9,48	44079	10,73	44086	10,38	66485	16,86
6,00	6,00	50,00	18,00	55680	22,95			44074	20,21	44081	22,95	44141	22,25	66486	29,31
6,30	3,00	45,00	12,70	55679	18,66			44073	15,99	44080	18,66	44122	17,59		
8,00	6,00	64,00	19,00	55681	28,95			44075	24,12	44082	28,95	44142	26,53	66487	34,07
9,60	6,00	64,00	19,00	44070	32,84	55864	39,74	44076	27,40	44083	32,84	44143	30,11	43567	36,45
12,70	6,00	70,00	25,00	44071	44,27	55866	71,97	44077	38,44	44084	46,16	44144	42,32	66488	66,03
12,70	8,00	70,00	25,00	55691	44,29			55689	36,94			55690	40,64		
16,00	6,00	70,00	25,00	55682	60,24			44078	50,21	44085	60,24	44145	55,21		
16,00	8,00	70,00	25,00	55695	55,85			55692	46,57			55693	51,23		
19,00	6,00	70,00	25,00	55685	83,06			55683	69,27			55684	76,20		
25,00	6,00	70,00	25,00	55688	116,13			55686	96,85			55687	106,54		

Línea 33 cm
9200

FRESAS ROTATIVAS

Rotary Burrs

Fraises limes rotatives



Ref	9251	9251	9251	9251	9260	9260
Diam	6x6	8x6	9,6x6	12,7x6	9,6x6	12,7x6
Dent./Teeth	6	6	6	6	6	6
Pcs.	2	2	2	2	2	2

Ref. 4995 - Nº Art. 71009: **388,63 €**

Ref. **9250**

FRESA ROTATIVA MD ZYA

ZYA HM Rotary Burr
Fraise lime rotative carbure ZYA



MD
HM
Carbure

MD/HM
+
ALTIN

Norma
ZYA
Norm

Tipo
A
Type

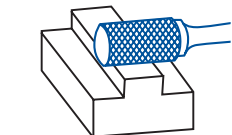
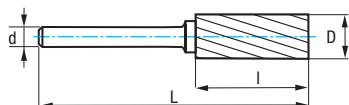

1
MATERIALES NO FERROSOS
Non-Ferrous Materials
Matériaux non ferreux



3
USO GENERAL
General Purpose
Utilisation Générale



4
VIRUTA CORTA
Short Chipping
Copeaux Courts



6
MATERIALES DUROS
Hard Materials
Matériaux Durs

D mm	d mm	L mm	I mm	Dentado Teeth / Denture 1		Dentado Teeth / Denture 1 ALTIN		Dentado Teeth / Denture 3		Dentado Teeth / Denture 4		Dentado Teeth / Denture 6		Dentado Teeth / Denture 6 ALTIN	
				Nº Art.	€	Nº Art.	€	Nº Art.	€	Nº Art.	€	Nº Art.	€	Nº Art.	€
3,00	3,00	38,00	14,00	55644	9,79			44149	8,48	44156	9,79	44245	9,32	66489	15,28
6,00	6,00	50,00	18,00	55648	20,85			44151	18,26	44158	20,85	44417	20,07	66490	26,37
6,30	3,00	45,00	12,70	55645	16,95			44150	14,34	44157	16,95	44301	15,78		
8,00	6,00	64,00	19,00	55651	26,59			44152	22,17	44159	26,59	44418	24,37	66491	31,00
9,60	6,00	64,00	19,00	44147	29,71	55861	45,15	44153	24,77	44160	29,71	44419	27,26	63933	41,43
12,70	6,00	70,00	25,00	44148	40,25	55863	65,44	44154	35,21	44161	42,24	44421	38,72	66492	60,04
12,70	8,00	70,00	25,00	55671	42,20			55669	35,21			55670	38,72		
16,00	6,00	70,00	25,00	55653	54,76			44155	45,63	44173	54,76	44422	50,21		
16,00	8,00	70,00	25,00	55675	50,76			55672	42,34			55673	46,57		
19,00	6,00	70,00	25,00	55664	75,51			55655	62,97			55657	69,27		
25,00	6,00	70,00	25,00	55668	105,58			55666	88,05			55667	96,86		

Ref. **9251**

FRESA ROTATIVA MD WRC RADIAL

Radial WRC HM Rotary Burr
Fraise lime rotative carbure WRC hemisférica



MD
HM
Carbure

MD/HM
+
ALTIN

Norma
WRC
Norm

Tipo
C
Type

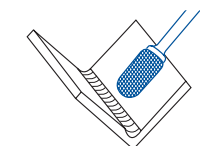
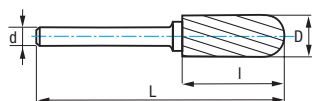

1
MATERIALES NO FERROSOS
Non-Ferrous Materials
Matériaux non ferreux



3
USO GENERAL
General Purpose
Utilisation Générale



4
VIRUTA CORTA
Short Chipping
Copeaux Courts



6
MATERIALES DUROS
Hard Materials
Matériaux Durs



S
TITANIO, INCONEL...
Titanium, Inconel...
Titane, Inconel...

D mm	d mm	L mm	I mm	Dentado Teeth / Denture 1		Dentado Teeth / Denture 1 ALTIN		Dentado Teeth / Denture 3		Dentado Teeth / Denture 4		Dentado Teeth / Denture 6		Dentado Teeth / Denture 6 ALTIN		Dentado Teeth / Denture S ALTIN	
				Nº Art.	€	Nº Art.	€	Nº Art.	€	Nº Art.	€	Nº Art.	€	Nº Art.	€	Nº Art.	€
3,00	3,00	38,00	14,00	55696	12,54			44425	10,43	44431	12,54	44437	11,47	66493	15,28	83022	15,28
6,00	6,00	50,00	18,00	55698	23,49			44426	19,55	44432	23,49	44438	21,52	66494	27,02		
8,00	6,00	64,00	18,00	55699	28,95			44427	24,12	44433	28,95	44439	26,53	66495	33,73		
9,60	6,00	64,00	19,00	44423	33,63	55867	50,27	44428	28,02	44434	33,63	44440	30,82	66496	46,12		
12,70	6,00	70,00	25,00	44424	46,92	55868	73,40	44429	39,12	44435	46,92	44441	43,02	66497	67,33		
12,70	8,00	70,00	25,00	55708	45,16			55706	37,67			55707	41,44				
16,00	6,00	70,00	25,00	12138	61,01			44430	50,85	44436	61,01	44442	55,94				
16,00	8,00	70,00	25,00	55711	56,84			55709	47,40			55710	52,14				
19,00	6,00	70,00	25,00	55702	81,59			55700	68,05			55701	74,86				
25,00	6,00	70,00	25,00					55704	92,46			55705	101,69				

Ref. **9252**

FRESA ROTATIVA MD WKN CONO INVERTIDO

Inverted Cone WKN HM Rotary Burr

Fraise lime rotative carbure WKN sans coupe en bout



MD
HM
Carbure

Norma
WKN
Norm

Tipo
N
Type

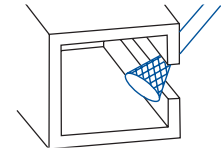
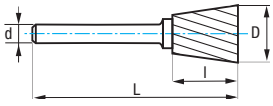

USO GENERAL
General Purpose
Utilisation Générale



VIRUTA CORTA
Short Chipping
Copeaux Courts



MATERIALES DUROS
Hard Materials
Matériaux Durs

D mm	d mm	L mm	l mm	Ang.	Dentado Teeth / Denture 3		Dentado Teeth / Denture 4		Dentado Teeth / Denture 6	
					Nº Art.	€	Nº Art.	€	Nº Art.	€
3,00	3,00	38,00	4,00	10°	44443	10,43	44450	12,54	44455	11,47
6,00	6,00	50,00	8,00	10°	44447	18,26	44452	21,91	44458	20,08
6,30	3,00	39,00	6,00	12°	44445	16,31	44451	19,57	44457	17,95
12,70	6,00	57,00	12,00	28°	44448	28,78	44453	34,54	44460	31,65
12,70	8,00	58,00	12,70	28°	55825	37,45			55826	41,21
16,00	6,00	64,00	19,00	18°	44449	48,11	44454	57,67	44461	52,91
16,00	8,00	64,00	19,00	18°	55827	48,11			55828	52,91
19,00	6,00	61,00	16,00	30°	55823	54,05			55824	59,45

Ref. **9254**

FRESA ROTATIVA MD SPG OJIVA

Tree SPG HM Rotary Burr

Fraise lime rotative carbure SPG ojive



MD
HM
Carbure

MD/HM
+
ALTIM

Norma
SPG
Norm

Tipo
G
Type

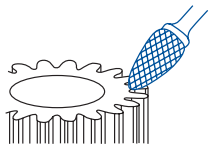
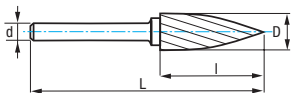

MAT. NO FERROSOS
Non-Ferrous Mat.
Mat. non ferreux



USO GENERAL
General Purpose
Utilisation Générale



VIRUTA CORTA
Short Chipping
Copeaux Courts



MATERIALES DUROS
Hard Materials
Matériaux Durs

D mm	d mm	L mm	l mm	Dentado Teeth / Denture 1		Dentado Teeth / Denture 3		Dentado Teeth / Denture 4		Dentado Teeth / Denture 6		Dentado Teeth / Denture 6 ALTIM	
				Nº Art.	€	Nº Art.	€	Nº Art.	€	Nº Art.	€	Nº Art.	€
3,00	3,00	38,00	14,00	55783	12,54	44466	10,43	44472	12,54	44487	11,47	66505	15,28
6,00	6,00	50,00	18,00	55784	23,49	44467	19,55	44473	23,49	44488	21,52	66506	26,75
8,00	6,00	64,00	19,00	55785	26,59	44468	22,17	44474	26,59	44494	24,33		
9,60	6,00	64,00	19,00	44463	31,29	44469	26,09	44475	31,29	44500	28,68	55882	38,52
12,70	6,00	70,00	25,00	44464	39,12	44470	32,59	44476	39,12	44512	35,86	27566	48,64
12,70	8,00	70,00	25,00	55787	40,77	17105	34,00			55786	37,42		
16,00	6,00	70,00	25,00					44482	54,76				
16,00	6,00	75,00	30,00	44465	54,76	44471	45,63			44518	50,21		
16,00	8,00	70,00	25,00	55790	56,72	55788	47,31			55789	52,04		

Ref. **9255**

FRESA ROTATIVA MD SKM CÓNICA

Cone SKM HM Rotary Burr
Fraise lime rotative carbure SKM conique



MD
HM
Carbure

Norma
SKM
Norm

Tipo
M
Type

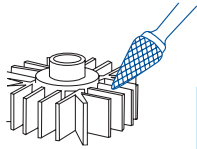
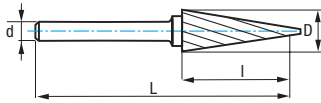

1
MAT. NO FERROSOS
Non-Ferrous Mat.
Mat. non ferreux



3
USO GENERAL
General Purpose
Utilisation Générale



4
VIRUTA CORTA
Short Chipping
Copeaux Courts



6
MATERIALES DUROS
Hard Materials
Matériaux Durs

D mm	d mm	L mm	l mm	Ang.	Dentado Teeth / Denture 1		Dentado Teeth / Denture 3		Dentado Teeth / Denture 4		Dentado Teeth / Denture 6	
					Nº Art.	€	Nº Art.	€	Nº Art.	€	Nº Art.	€
6,00	6,00	50,00	20,00	14°	55817	21,67	44530	18,05	44598	21,67	44616	19,85
6,30	3,00	49,00	12,70	22°	55816	18,05	44524	15,06	44595	18,05	44613	16,55
8,00	6,00	64,00	18,00	22°			44583	19,26	44601	23,11	44617	21,20
9,60	6,00	64,00	16,00	28°	55818	26,00	44586	21,67	44604	26,00	44619	23,84
12,70	6,00	71,00	22,00	28°	25335	34,68	44589	28,87	44607	34,68	44620	31,77
12,70	8,00	71,00	22,00	28°			55819	37,61			55820	41,38
16,00	6,00	71,00	25,00	31°			44592	39,12	44610	46,93	44622	43,02
16,00	8,00	71,00	25,00	31°			55821	50,20			55822	55,22

Ref. **9256**

FRESA ROTATIVA MD KSK CÓNICA 90°

90° Cone KSK HM Rotary Burr
Fraise lime rotative carbure KSK conique 90°



MD
HM
Carbure

Norma
KSK
Norm

Tipo
K
Type

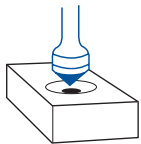
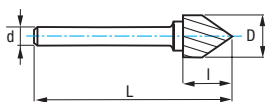

3
USO GENERAL
General Purpose
Utilisation Générale



4
VIRUTA CORTA
Short Chipping
Copeaux Courts



6
MATERIALES DUROS
Hard Materials
Matériaux Durs

D mm	d mm	L mm	l mm	Dentado Teeth / Denture 3		Dentado Teeth / Denture 4		Dentado Teeth / Denture 6	
				Nº Art.	€	Nº Art.	€	Nº Art.	€
6,00	6,00	50,00	3,00	44625	15,65	44628	18,76	44631	17,22
12,70	6,00	55,00	6,30	44626	26,09	44629	31,27	44632	28,68
12,70	8,00	55,00	6,30	55802	26,03			55803	28,64
16,00	6,00	57,00	8,00	55796	34,69			55797	38,15
16,00	8,00	57,00	8,00	55804	34,69			55805	38,15
19,00	6,00	59,00	9,50	55798	45,54			55799	50,10
25,00	6,00	61,00	12,70	55800	73,07			55801	80,37

Ref. **9257**

FRESA ROTATIVA MD TRE GOTA

Oval TRE HM Rotary Burr
Fraise lime rotative carbure TRE ovale



MD
HM
Carbure

Norma
TRE
Norm

Tipo
E
Type

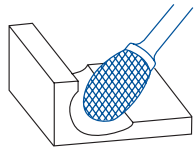
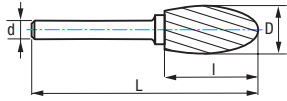

1
MAT. NO FERROSOS
Non-Ferrous Mat.
Mat. non ferreux



3
USO GENERAL
General Purpose
Utilisation Générale



4
VIRUTA CORTA
Short Chipping
Copeaux Courts



6
MATERIALES DUROS
Hard Materials
Matériaux Durs

D mm	d mm	L mm	l mm	Dentado Teeth / Denture 1		Dentado Teeth / Denture 3		Dentado Teeth / Denture 4		Dentado Teeth / Denture 6	
				Nº Art.	€	Nº Art.	€	Nº Art.	€	Nº Art.	€
3,00	3,00	38,00	6,00	55733	12,54	44637	10,43	44648	12,54	44655	11,47
6,00	6,00	50,00	10,00	55735	23,49	44640	19,55	44650	23,49	44657	21,52
6,30	3,00	42,00	9,50	55734	19,55	44638	16,31	44649	19,55	44656	17,92
8,00	6,00	60,00	15,00	55737	26,59	44643	22,17	44651	26,59	44658	24,37
9,60	6,00	61,00	16,00	44634	31,29	44644	26,09	44652	31,29	44659	28,68
12,70	6,00	67,00	22,00	44635	39,12	44646	32,59	44653	39,12	44660	35,86
12,70	8,00	67,00	22,00	55746	42,06	55743	35,10			55744	38,59
16,00	6,00	70,00	25,00	55738	54,76	44647	45,63	44654	54,76	44661	50,21
16,00	8,00	70,00	25,00	55749	58,46	55747	48,76			55748	53,63
19,00	6,00	70,00	25,00	55741	78,52	55739	65,48			55740	72,03

Ref. **9258**

FRESA ROTATIVA MD KUD ESFÉRICA

Ball KUD HM Rotary Burr
Fraise lime rotative carbure KUD esférica



MD
HM
Carbure

MD/HM
+
ALTIM

Norma
KUD
Norm

Tipo
D
Type

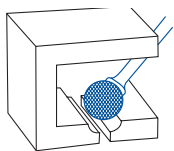
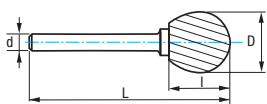

1
MATERIALES NO FERROSOS
Non-Ferrous Materials
Matériaux non ferreux



3
USO GENERAL
General Purpose
Utilisation Générale



4
VIRUTA CORTA
Short Chipping
Copeaux Courts



6
MATERIALES DUROS
Hard Materials
Matériaux Durs

D mm	d mm	L mm	l mm	Dentado Teeth / Denture 1		Dentado Teeth / Denture 1 ALTIM		Dentado Teeth / Denture 3		Dentado Teeth / Denture 4		Dentado Teeth / Denture 6		Dentado Teeth / Denture 6 ALTIM	
				Nº Art.	€	Nº Art.	€	Nº Art.	€	Nº Art.	€	Nº Art.	€	Nº Art.	€
3,00	3,00	38,00	2,50	55713	11,57			44705	9,63	44712	11,57	44719	10,57	66498	15,28
6,00	6,00	50,00	4,70	55716	21,67			44707	18,05	44714	21,67	44721	19,85	66499	24,62
6,30	3,00	38,00	5,00	55714	18,05			44706	15,06	44713	18,05	44720	16,55		
8,00	6,00	52,00	6,00	55717	24,57			44708	20,47	44715	24,57	44722	22,47	66500	27,25
9,60	6,00	54,00	8,00	44662	27,44	55869	41,25	44709	22,86	44716	27,44	44723	25,12	66501	37,84
12,70	6,00	56,00	11,00	44671	34,68	55870	51,70	44710	28,87	44717	34,68	44724	31,77	66502	47,44
12,70	8,00	56,00	11,00	55728	31,82			55725	26,53			55726	29,19		
16,00	6,00	59,00	14,00	58481	48,87			44711	40,90	44718	49,09	44725	44,83		
16,00	8,00	59,00	14,00	55732	39,43			55729	32,88			55731	36,18		
19,00	6,00	62,00	16,50	55720	54,42			55718	45,39			55719	49,93		
25,00	6,00	67,00	22,00	55724	93,50			55722	77,98			55723	85,77		

Ref. **9266**

FRESA ROTATIVA MD B LLAMA

Flame B HM Rotary Burr
Fraise lime rotative carbure B flamma



MD
HM
Carbure

Norma
B
Norm

Tipo
H
Type

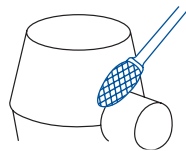
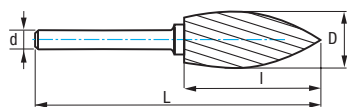

1
MAT. NO FERROSOS
Non-Ferrous Mat.
Mat. non ferreux



3
USO GENERAL
General Purpose
Utilisation Générale



4
VIRUTA CORTA
Short Chipping
Copeaux Courts



6
MATERIALES DUROS
Hard Materials
Matériaux Durs

D mm	d mm	L mm	l mm	Dentado Teeth / Denture 1		Dentado Teeth / Denture 3		Dentado Teeth / Denture 4		Dentado Teeth / Denture 6	
				Nº Art.	€	Nº Art.	€	Nº Art.	€	Nº Art.	€
3,00	3,00	38,00	6,00			44728	8,93	44735	10,70	44757	9,81
6,00	3,00	43,00	10,00			44729	14,65	44736	17,56	44760	16,10
6,00	6,00	50,00	14,00			44730	18,59	44737	25,02	44763	22,95
8,00	6,00	64,00	19,00	55791	28,18	44731	23,49	44738	28,18	44766	25,81
9,60	6,00	65,00	19,00	44726	33,63	44732	28,02	44739	33,63	44769	30,82
12,70	6,00	77,00	32,00	44727	40,68	44733	33,92	44740	40,68	44771	37,28
12,70	8,00	77,00	32,00			55792	50,20			55793	55,22
16,00	6,00	81,00	36,00	44773	57,87	44734	48,24	44742	57,87	44772	53,06
16,00	8,00	81,00	36,00			55794	69,33			55795	76,28

Ref. **9267**

FRESA ROTATIVA MD KEL CÓNICA REDONDEADA

Ball Nosed Cone KEL HM Rotary Burr
Fraise lime rotative carbure KEL conique rayon



MD
HM
Carbure

Norma
KEL
Norm

Tipo
L
Type

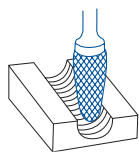
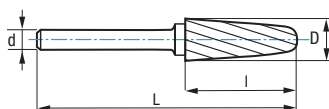

1
MAT. NO FERROSOS
Non-Ferrous Mat.
Mat. non ferreux



3
USO GENERAL
General Purpose
Utilisation Générale



4
VIRUTA CORTA
Short Chipping
Copeaux Courts



6
MATERIALES DUROS
Hard Materials
Matériaux Durs

D mm	d mm	L mm	l mm	Ang.	Dentado Teeth / Denture 1		Dentado Teeth / Denture 1 ALTIN		Dentado Teeth / Denture 3		Dentado Teeth / Denture 4		Dentado Teeth / Denture 6		Dentado Teeth / Denture 6 ALTIN	
					Nº Art.	€	Nº Art.	€	Nº Art.	€	Nº Art.	€	Nº Art.	€	Nº Art.	€
3,00	3,00	38,00	14,00	10°	55806	12,54			44776	10,43	44783	12,54	44790	11,47	66507	15,28
6,00	6,00	50,00	18,00	14°	55808	25,81			44778	21,52	44785	25,81	44792	23,65		
6,30	3,00	48,00	15,80	22°	55807	19,55			44777	16,31	44784	19,55	44791	17,95		
8,00	6,00	70,00	25,40	14°	55809	31,37			44779	26,09	44786	31,37	44793	28,68		
10,00	6,00	65,00	20,00	14°	21959	37,57			44780	31,29	44787	37,57	44794	34,39		
12,70	6,00	77,00	32,00	14°	44774	46,92	66508	57,40	44781	39,12	44788	46,92	44795	43,02	20159	52,67
12,70	8,00	77,00	32,00	14°	55812	43,91			55810	36,62			55811	40,28		
16,00	6,00	78,00	33,00	14°	44775	70,41			44782	58,66	44789	70,41	44796	64,55		
16,00	8,00	78,00	33,00	14°	55815	86,41			55813	72,07			55814	79,27		

Ref. **9268**

FRESA ROTATIVA MD RBF OJIVA REDONDEADA

Ball Nosed Tree RBF HM Rotary Burr
Fraise lime rotative carbure RBF Ogive Rayon



MD HM Carbure	MD/HM + ALTiN	Norma RBF Norm	Tipo F Type
-----------------------------------	-----------------------------------	-----------------------------	--------------------------

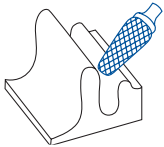
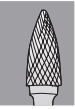
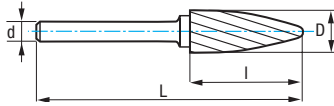

1
MATERIALES NO FERROSOS
Non-Ferrous Materials
Matériaux non ferreux



3
USO GENERAL
General Purpose
Utilisation Générale



4
VIRUTA CORTA
Short Chipping
Copeaux Courts



6
MATERIALES DUROS
Hard Materials
Matériaux Durs

D mm	d mm	L mm	l mm	Dentado Teeth / Denture 1		Dentado Teeth / Denture 1 ALTiN		Dentado Teeth / Denture 3		Dentado Teeth / Denture 4		Dentado Teeth / Denture 6		Dentado Teeth / Denture 6 ALTiN	
				N° Art.	€	N° Art.	€	N° Art.	€	N° Art.	€	N° Art.	€	N° Art.	€
3,00	3,00	38,00	14,00	55753	10,70			55750	8,93			17118	9,81	66503	15,28
6,00	6,00	50,00	18,00	55759	25,81			44797	21,52	44802	25,81	44808	23,65	66504	29,12
6,30	3,00	45,00	12,70	55758	17,56			55755	14,65			55756	16,10		
8,00	6,00	65,00	20,00	55760	31,29			44798	26,09	44803	31,29	44809	28,68		
9,60	6,00	64,00	19,00	55761	37,57	55880	39,35	44799	31,29	44804	37,57	44811	34,39	17250	36,10
12,70	6,00	70,00	25,00	55762	46,92	55881	54,05	44800	39,12	44805	46,92	44814	43,02	23849	49,60
12,70	8,00	70,00	25,00	55777	41,59			55774	34,69			55776	38,15		
16,00	6,00	70,00	25,00	55765	70,41			44801	58,66	44806	70,41	44817	64,55		
16,00	8,00	70,00	25,00	55782	57,42			55779	47,88			55780	52,68		
19,00	6,00	83,00	38,00	55771	111,62			55768	93,10			55769	102,39		

Ref. **9240**

FRESA ROTATIVA MD ZYA-S LARGA

Long ZYA-S HM Rotary Burr
Fraise lime rotative carbure ZYA-S longue



MD HM Carbure	Norma ZYA-S Norm		Tipo B Type
-----------------------------------	-------------------------------	--	--------------------------

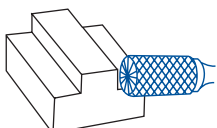
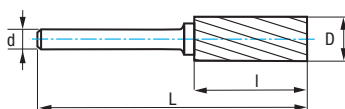

3
USO GENERAL
General Purpose
Utilisation Générale



6
MATERIALES DUROS
Hard Materials
Matériaux Durs

D mm	d mm	L mm	l mm	Dentado Teeth / Denture 3		Dentado Teeth / Denture 6	
				N° Art.	€	N° Art.	€
6,00	6,00	150,00	18,00	55832	68,91	55833	75,80
9,60	6,00	172,00	19,00	55834	46,19	55835	50,83
12,70	6,00	178,00	25,00	55836	65,39	55837	71,93

Ref. **9230**

FRESA ROTATIVA MD ZYA LARGA

Long ZYA HM Rotary Burr
Fraise Lime Rotative Carbure ZYA longue



MD
HM
Carbure

Norma
ZYA
Norm



Tipo
A
Type



MATERIALES DUROS
Hard Materials
Matériaux Durs

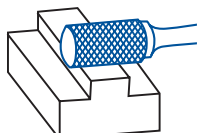
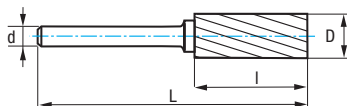

Dentado					
Teeth / Denture					
D	d	L	l	N° Art.	€
mm	mm	mm	mm	6	
6,00	6,00	150,00	18,00	55829	68,91
9,60	6,00	172,00	19,00	55830	46,19
12,70	6,00	178,00	25,00	55831	65,39



Ref. **9231**

FRESA ROTATIVA MD WRC RADIAL LARGA

Long Radial WRC HM Rotary Burr
Fraise lime rotative carbure WRC hemisphérique longue



MD
HM
Carbure

Norma
WRC
Norm

Tipo
C
Type



MATERIALES DUROS
Hard Materials
Matériaux Durs

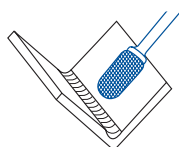
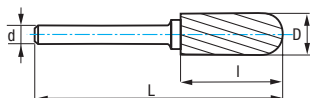

Dentado					
Teeth / Denture					
D	d	L	l	N° Art.	€
mm	mm	mm	mm	6	
6,00	6,00	150,00	18,00	55838	70,46
9,60	6,00	172,00	19,00	55839	43,36
12,70	6,00	178,00	25,00	55840	61,51



Ref. **9237**

FRESA ROTATIVA MD TRE GOTA LARGA

Long Oval TRE HM Rotary Burr
Fraise lime rotative carbure TRE ovale longue



MD
HM
Carbure

Norma
TRE
Norm

Tipo
E
Type



3
USO GENERAL
General Purpose
Utilisation Générale



6
MATERIALES DUROS
Hard Materials
Matériaux Durs

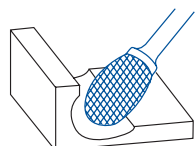
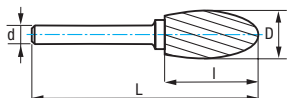

D mm	d mm	L mm	l mm	Dentado Teeth / Denture 3		Dentado Teeth / Denture 6	
				N° Art.	€	N° Art.	€
9,60	6,00	168,00	16,00	55849	39,66	55851	43,62
12,70	6,00	184,00	22,00	55852	49,20	55854	54,12

Ref. **9238**

FRESA ROTATIVA MD KUD ESFÉRICA LARGA

Long Ball KUD HM Rotary Burr
Fraise lime rotative carbure KUD esférica longue

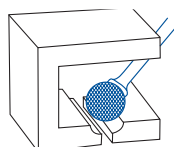
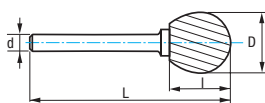

MD
HM
Carbure

Norma
KUD
Norm

Tipo
D
Type



3
USO GENERAL
General Purpose
Utilisation Générale



6
MATERIALES DUROS
Hard Materials
Matériaux Durs

D mm	d mm	L mm	l mm	Dentado Teeth / Denture 3		Dentado Teeth / Denture 6	
				N° Art.	€	N° Art.	€
8,00	6,00	182,00	6,00	55841	33,40	55842	36,73
9,60	6,00	170,00	8,00	55843	33,94	55845	37,34
12,70	6,00	175,00	11,00	55846	41,61	55848	45,77

Ref. **9247**

FRESA ROTATIVA MD KEL CÓNICA REDONDEADA LARGA

Long Ball Nosed Cone KEL HM Rotary Burr

Fraise lime rotative carbure KEL conique rayon longue

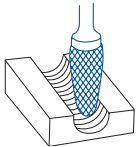
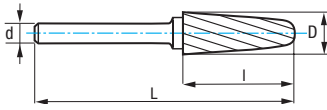

MD HM	Norma KEL	Tipo L
Carbure	Norm	Type



MATERIALES DUROS
Hard Materials
Matériaux Durs

						Dentado	
						Teeth / Denture	
D	d	L	l	Ang.		6	
mm	mm	mm	mm				
						Nº Art.	€
9,60	6,00	183,00	30,00	14°		55858	53,08
12,70	6,00	185,00	30,20	14°		55860	59,71

Ref. **9248**

FRESA ROTATIVA MD RBF OJIVA REDONDEADA LARGA

Long Ball Nosed Tree RBF HM Rotary Burr

Fraise lime rotative carbure RBF ogive rayon longue

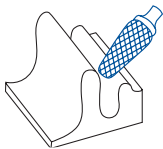
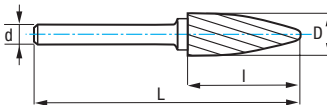

MD HM	Norma RBF	Tipo F
Carbure	Norm	Type



MATERIALES DUROS
Hard Materials
Matériaux Durs

						Dentado	
						Teeth / Denture	
D	d	L	l			6	
mm	mm	mm	mm				
						Nº Art.	€
9,60	6,00	172,00	19,00			55855	41,56
12,70	6,00	178,00	25,00			55857	54,29

Ref. **9200**

JUEGOS FRESAS ROTATIVAS MD

HM Rotary Burr Sets

Jeux fraises limes rotatives carbure



Mod. 1
Set 5 Pcs



MAT. NO FERROSOS
Non-Ferrous Mat.
Mat. non ferreux



MATERIALES DUROS
Hard Materials
Matériaux Durs

Cont. (1 x ref.)	D mm	d mm	Dentado Teeth / Denture 1		Dentado Teeth / Denture 6	
			Nº Art.	€	Nº Art.	€
9260						
9251	12,70	6,00	60052	202,90	45810	186,15
9255						
9258	9,60	6,00			68857	140,70
9266						



Mod. 2
Set 10 Pcs



MATERIALES DUROS
Hard Materials
Matériaux Durs

Cont. (1 x ref.)	D mm	d mm	Dentado Teeth / Denture 6	
			Nº Art.	€
9260				
9250				
9251				
9254				
9255	6,00	6,00	45811	206,53
9257				
9258				
9266				
9267				
9268				



Mod. 3
Set 8 Pcs



MATERIALES DUROS
Hard Materials
Matériaux Durs

Cont. (1 x ref.)	D mm	d mm	Dentado Teeth / Denture 6	
			Nº Art.	€
9260				
9250				
9251				
9254	3,00	3,00	45813	87,63
9257				
9258				
9267				
9268				



Mod. 4
Set 3 Pcs



MATERIALES DUROS
Hard Materials
Matériaux Durs

Cont. (1 x ref.)	D mm	d mm	Dentado Teeth / Denture 6	
			Nº Art.	€
9260				
9251	9,60	6,00	79826	89,60
9254				

Expo
9200

EXPOSITOR FRESAS ROTATIVAS

Rotary Burr Display

Présentoirs fraises limes rotatives carbure



Set 48 Pcs

Nº Art.	€
57079	1.424,32

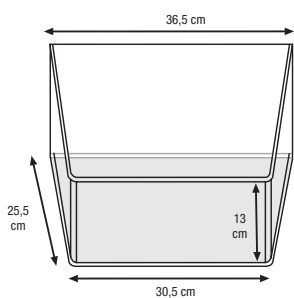

Ref.	Diam. mm	Nº Art.	Uds.	Ref.	Diam. mm	Nº Art.	Uds.	Ref.	Diam. mm	Nº Art.	Uds.
9260	06,00X06,00	44141	2	9254	06,00X06,00	44488	2	9267	06,00X06,00	44792	2
	08,00X06,00	44142	2		08,00X06,00	44494	2		08,00X06,00	44793	2
	09,60X06,00	44143	2		09,60X06,00	44500	2		10,00X06,00	44794	2
	12,70X06,00	44144	2		12,70X06,00	44512	2		12,70X06,00	44795	2
9251	06,00X06,00	44438	2	9258	06,00X06,00	44721	2	9268	06,00X06,00	44808	2
	08,00X06,00	44439	2		08,00X06,00	44722	2		08,00X06,00	44809	2
	09,60X06,00	44440	2		09,60X06,00	44723	2		09,60X06,00	44811	2
	12,70X06,00	44441	2		12,70X06,00	44724	2		12,70X06,00	44814	2

Ref. **9674**

FRESA RANURADO ALUCOBOND / DIBOND

Alucobond / Dibond Sheet Bending End Mill
Fraise rainurage Alucobond/Dibond



MD
HM
Carbure

IZAR
Std.



12000-15000
rpm

Vf: 400-600
mm/min

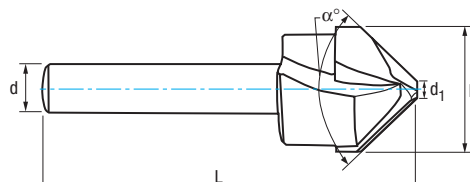

90°



2,5 mm

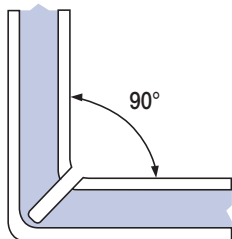
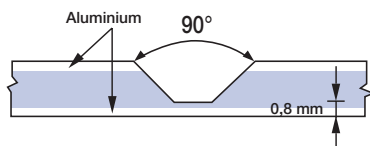

135°



2,3 mm

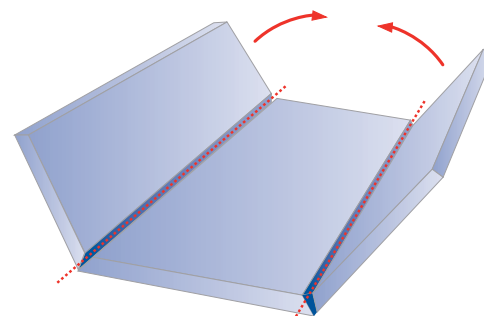
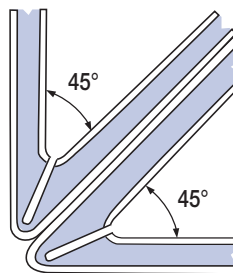
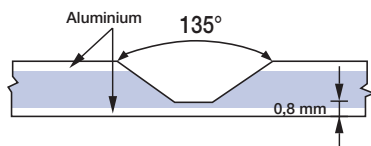

- Fresa especial para ranurados en Alucobond, Dibond, Durabond, Alupanel, Plexiglas, Alpolic, ACP, ACM...
- Se recomienda cortar casi hasta el fondo para poder doblar las planchas fácilmente.

- Special end mill for bending sheets of Alucobond, Dibond, Durabond, Alupanel, Plexiglas, Alpolic, ACP, ACM...
- The material should be cut almost until the bottom part leaving little amount of material left, that way the sheet will be bended easily.

- Fraise spécial pour rainurage sur Alucobond, Dibond, Durabond, Alupanel, Plexiglas, Alpolic, ACP, ACM...
- Il est recommandé de couper presque jusqu'au fond pour pouvoir plier les plaques facilement.

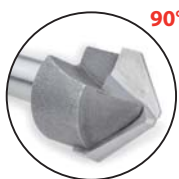

90°



135°

D mm	d mm	L mm	d ₁ mm	α °	N° Art.	€
α=90°						
16	8	59	2,5	90	81516	129,99
18	8	59	2,5	90	81519	131,85
20	8	59	2,5	90	81520	135,46

D mm	d mm	L mm	d ₁ mm	α °	N° Art.	€
α=135°						
16	8	59	2,3	135	81521	140,89
18	8	59	2,3	135	81522	153,65
20	8	59	2,3	135	81523	176,36

Ref. **9459**

FRESA 1Z GRABADO

1Z Engraving End Mill
Fraise 1Z gravure

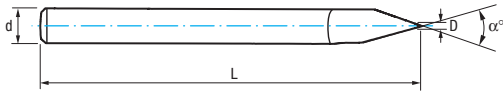

MD/HM/
Carbure
Micrograno

DIN
6535 HA

1Z

IZAR
std.

6000-
10000
r.p.m.

Aceros
<850 N/mm²
Steel / Aciers

Cobre
Copper
Cuivre

Aluminio
Aluminium

Plásticos
Plastics
Plastiques

Madera
Wood
Bois

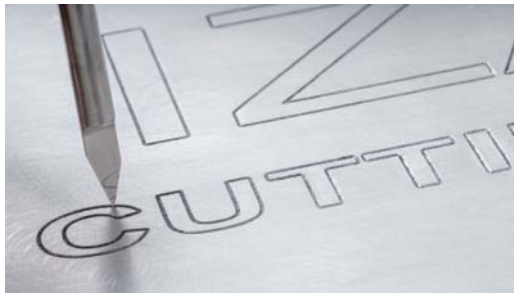

- **Afilado especial para grabado de metales, plásticos y maderas como: Aluminio, Cobre, Hierro, PVC, ABS, Metacrilato acrílico, Paneles bicolores, Madera MDF, etc.**
- **Specially designed geometry for engraving on Metal, Plastic and Wood. Valid for Aluminum, Copper, Iron, PVC, ABS, Acrylic, Bi-color panel, MDF fibreboard, etc.**
- **Géométrie spécial pour gravure de métaux, plastiques et bois telles que: Aluminium, cuivre, fer, PVC, ABS, méthacrylate acrylique, panneaux bicolores, bois MDF, etc.**

D	d	L	N°	€	D	d	L	N°	€	D	d	L	N°	€	D	d	L	N°	€
mm	mm	mm	Art.		mm	mm	mm	Art.		mm	mm	mm	Art.		mm	mm	mm	Art.	
α=30°					α=45°					α=60°					α=90°				
0,1	3,00	38	81048	8,06	0,1	3,00	38	81052	8,06	0,1	3,00	38	81055	8,06	0,1	3,00	38	81058	8,06
0,2	3,00	38	81049	8,06	0,2	3,00	38	81053	8,06	0,2	3,00	38	81056	8,06	0,2	3,00	38	81059	8,06
0,4	3,00	38	81050	8,06	0,2	4,00	45	81062	10,65	0,2	4,00	45	81065	10,65	0,2	4,00	45	81068	10,65
0,8	3,00	38	81051	8,06	0,2	6,00	50	81071	17,03	0,2	6,00	50	81080	17,03	0,2	6,00	50	81084	17,03
					0,4	3,00	38	81054	8,06	0,4	3,00	38	81057	8,06	0,4	3,00	38	81060	8,06
					0,4	4,00	45	81063	10,65	0,4	4,00	45	81066	10,65	0,4	4,00	45	81069	10,65
					0,4	6,00	50	81072	17,03	0,4	6,00	50	81081	17,03	0,4	6,00	50	81086	17,03
					0,8	4,00	45	81064	10,65	0,8	4,00	45	81067	10,65	0,8	4,00	45	81070	10,65
					0,8	6,00	50	81077	17,03	0,8	6,00	50	81082	17,03	0,8	6,00	50	81088	17,03
					2,0	6,00	50	81079	17,03	2,0	6,00	50	81083	17,03	2,0	6,00	50	81089	17,03

ALTIN bajo demanda / upon request / sur demande



Set 4 Pcs

Cont. D mm	N° Art.	€
0,1 mm 30° 0,2 mm 30° 0,4 mm 30° 0,8 mm 30°	81958	30,65

Cont. D mm	N° Art.	€
0,1 mm 30° 0,1 mm 45° 0,1 mm 60° 0,1 mm 90°	81959	30,65

Ref. **9419**

FRESA FRONTAL ACABADO METAL DURO 1Z ALTO RENDIMIENTO

High Performance 1Z HM Finishing End Mill
Fraise finition carbure 1Z haut rendement



MD/HM Carbure
Micrograno+

K10F
+
ALTIN

W



Tol.
D (h10)
d (h6)



Aluminio
Aluminium

Plásticos
Plastics
Plastiques

ALTIN
Mayor resistencia al desgaste
Higher Wear Resistance
Plus haute à l'usure



D mm	d mm	L mm	l mm	Z	Nº Art. MD/HM	€	Nº Art. ALTIN	€
3,00	3,00	38	12	1	58984	12,80	59195	19,61
4,00	4,00	40	15	1	58856	15,58	59196	22,28
5,00	5,00	50	16	1	58857	19,26	59197	25,78
6,00	6,00	50	18	1	58859	22,88	59198	29,23
8,00	8,00	63	22	1	58860	34,73	59199	41,67
10,00	10,00	72	30	1	58862	48,55	59201	54,68

Ref. **9411**

FRESA FRONTAL 1Z ALUMINIO METAL DURO

HM Aluminium 1Z End Mill
Fraise 1Z Aluminium carbure



MD/HM Carbure
Micrograno+

K10F
+
ALTIN

W



Tol.
D (h10)
d (h6)



Aluminio
Aluminium

Plásticos
Plastics
Plastiques

ALTIN
Mayor resistencia al desgaste
Higher Wear Resistance
Plus haute à l'usure



D mm	d mm	L mm	l mm	Z	Nº Art. MD/HM	€	Nº Art. ALTIN	€
3,00	3,00	38	12	1	13075	12,80	13114	19,61
4,00	4,00	40	12	1	13078	15,58	13123	22,28
5,00	5,00	50	12	1	13084	19,26	13126	25,78
6,00	6,00	50	14	1	13096	22,88	13135	29,23
8,00	8,00	63	15	1	13105	34,73	13138	41,67
10,00	10,00	72	15	1	13111	48,55	13144	54,68



Ref. **4412**

FRESA FRONTAL ACABADO HSS 1Z ALUMINIO

Aluminium 1Z HSS Finishing End Mill
Fraise finition HSS 1Z Aluminium



HSS	IZAR Std. W	Serie Corta Short Length Série courte	DIN 6535 HA	d= 8-10 mm	Tol.* D (k10) d (h6)	*øD=ød =>Tol. D (js14) d (h6)
------------	-------------------	--	----------------	---------------	----------------------------	-------------------------------------

Aluminio
Aluminium

Termoplásticos
Thermoplastics
Thermoplastiques

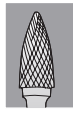

D mm	d mm	L mm	l mm	Z	Nº Art.	€
3,00	8	60	12	1	44087	11,32
4,00	8	60	12	1	44090	11,32
5,00	8	60	12	1	44093	11,32
6,00	8	60	14	1	44096	11,32
7,00	8	60	14	1	44099	13,83
8,00	8	80	15	1	44102	13,83
10,00	10	80	15	1	44105	14,23

Ref. **4414**

FRESA FRONTAL ACABADO HSS 1Z ALUMINIO

Aluminium 1Z HSS Finishing End Mill
Fraise finition HSS 1Z Aluminium



HSS	IZAR Std. W	Serie Larga Long Series Série longue	DIN 6535 HA	d= 8-10 mm	Y	Tol.* D (k10) d (h6)	*øD=ød =>Tol. D (js14) d (h6)
------------	-------------------	---	----------------	---------------	---	----------------------------	-------------------------------------

Aluminio
Aluminium

Termoplásticos
Thermoplastics
Thermoplastiques



D mm	d mm	L mm	l mm	Y mm	Z	Nº Art.	€
4,00	8	80	16	29	1	44120	16,00
5,00	8	80	16	29	1	44123	16,00
6,00	8	90	16	29	1	44126	16,00
8,00	8	100	28	40	1	44129	17,76
10,00	10	120	40	40	1	29178	18,30



HOJAS DE SIERRA DE CINTA

Band Saw Blades

Lames de scie à ruban

SELECCIÓN DE LA HOJA CORRECTA / Selecting the right Blade / Selection adaptée

1. Longitud de la Cinta (L)

La dimensión de la cinta depende únicamente de la máquina de corte empleada.

2. Ancho de la Cinta (A)

En las máquinas horizontales la anchura de la cinta es especificada por el fabricante.

Las máquinas verticales permiten mayores variaciones en la anchura de la cinta.

Sin embargo, la norma general es que cuanto más ancha es la hoja de sierra de cinta, mayor es su estabilidad.

Para el corte de contornos, el radio más pequeño a cortar limita el ancho de la cinta.

3. Espesor de la Cinta (E)

Cuanto más ancha es la hoja de sierra de cinta, mayor es su espesor.

4. Dentado (TPI)

El dentado es el nº de dientes por pulgada (25,4 mm).

Los dentados se diferencian en constantes, paso de diente uniforme, y variables, con diferente paso de diente dentro de cada intervalo.

Los dentados variables se definen con dos medidas, p.e. 2-3 TPI: 2 TPI significa el paso de diente máximo, y 3 TPI significa el paso de diente mínimo en el intervalo de dentado.

Aquí, la longitud de contacto de la sierra de cinta con la pieza a cortar es decisiva.

5. Forma Diente (TZ)

Diente estándar (S)

Angulo desprendimiento 0°:

- materiales de viruta corta
- aceros de alto contenido en carbono
- preferiblemente acero de herramienta y hierro fundido
- materiales de poca sección de corte
- perfiles de pared delgada

Diente de garra (K)

Angulo de desprendimiento positivo para macizos:

- empleo universal
- metales no ferrosos y aceros con un contenido en carbono de < 0,8%
- aceros estructurales, aceros para extrusión en frío y aceros templados

1. Band Length (L)

The band dimension individually depends on the used cutting machine.

2. Band Width (A)

With horizontal machines the band width is specified by the manufacturer.

Vertical band saw machines allow higher variations of the band width.

However, the general rule is the wider the band saw blade the higher its stability.

In case of contour cuts the smallest radius to be cut is the limiting factor for the band width.

3. Band Thickness (E)

The wider the band saw blade the higher its thickness.

4. Tooth pitch (TPI)

Tooth pitch is the number of teeth per inch (25,4 mm).

A difference is made between constant tooth pitches with regular tooth distance and variable tooth pitches with differing tooth distance within one interval.

Variable tooth pitches are marked by two measures, e.g. 2-3 TPI: 2 TPI signifies the maximum tooth distance and 3 TPI signifies the minimum tooth distance in the toothing interval.

Here the contact length of the blade in the work piece is decisive.

5. Tooth Shape (TZ)

Raker tooth (S)

0° rake angle for:

- short-chipping materials
- steels with high carbon content
- preferably tool steel and cast iron
- materials with small cross-sections
- thin-walled profiles

Hook tooth (K)

Positive rake angle for solids:

- universal use
- non-ferrous metals and steels with a carbon content of < 0,8%
- structural steels, steels for cold extrusion, tempered steels

1. Longueur de Lame (L)

La dimension d'une lame dépend de la machine utilisée.

2. Largeur de la Lame (A)

Sur des machines horizontales, la largeur de la lame est spécifiée par le fabricant.

Les machines verticales permettent de plus grandes variations dans les largeurs de lames.

La règle est généralement la suivante: Plus la lame est large, plus la rigidité est importante.

En cas de contournage, la largeur du ruban est limitée par le plus petit rayon à scier.

3. Epaisseur de Lame (E)

Plus la lame est large, plus la épaisseur est importante.

4. Dentures (TPI)

La denture est au nº de dents par pouce (25,4 mm).

Une différence réside entre les dentures constantes, où l'écart entre deux pointes de dents reste égal et les dentures variables, où les valeurs des pas de dents sont différentes.

La denture variable est caractérisée par deux chiffres, p.e. 2-3 TPI: 2 TPI désigne l'écart maxi entre les dents et le chiffre 3 TPI l'écart mini entre les dents sur une séquence de denture.

La surface de contact de la lame sur la pièce à débiter est décisive.

5. Forme de Dent (TZ)

Dent standard (S)

Angle de coupe 0° pour:

- matériaux à copeaux courts
- aciers à forte teneur en carbone
- les fontes et aciers à outil
- pièces de petites sections
- profils à parois minces

Dent griffe (K)

Angle de coupe positif pour matériaux pleins:

- usage universel
- métaux non ferreux et aciers à teneur en carbone de < 0,8%
- aciers de construction, aciers pour extrusion à froid et aciers trempés

Ancho cinta y radio más pequeño Band widths and smallest radius Largeurs de lames et plus petit rayon

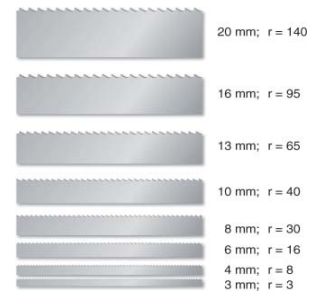

Dentado constante Constant tooth pitch Denture constante



Dentado variable Variable tooth pitch Denture variable



Tabla selección dentado Tooth selection table

Tableau sélection denture

Dentado Tooth Denture	Perfil Profile Profil	Macizo Solid Plein
10 / 14	0-1 mm	0-10 mm
8 / 12	1-2,5 mm	10-20 mm
6 / 10	2,5-5 mm	20-40 mm
5 / 8	5-7 mm	40-50 mm
4 / 6	7-10 mm	50-90 mm
3 / 4	>10 mm	90-120 mm
2 / 3		>120 mm
1,4 / 2		>250 mm

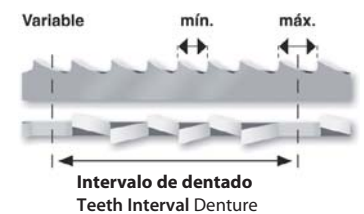
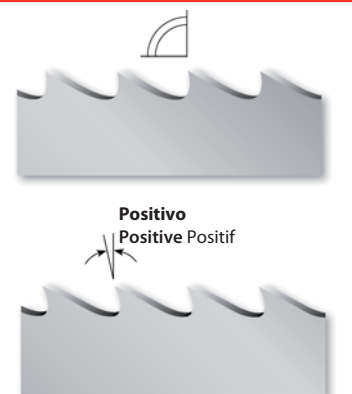

Ref. **4223**

HOJA DE SIERRA DE CINTA HSSE 8% Co IZARFLEX

IZARFLEX HSSE 8% Co Band Saw Blade
Lame de scie à ruban HSSE 8% Co IZARFLEX

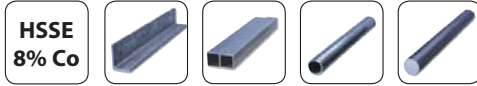
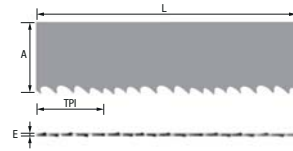

Aceros
<850 N/mm²
Steel / Aciers

Aceros
<1000 N/mm²
Steel / Aciers

Cobre
Copper
Cuivre

Aluminio
Aluminium

Plásticos
Plastics
Plastiques

Ideal para trabajos de taller exigentes, con los dientes de una calidad especial resistente al desgaste. Fleje flexible, bimetal, combina dentados 0 y +

Ideal for heavy duty workshop cutting tasks, with special wear resistant quality teeth. Flexible strip, bimetal, 0 & + teeth combined.

Idéal pour des travaux d'atelier exigeants, avec dents d'une qualité spéciale résistante à l'usure. Feuillard Flexible, bimétal, possibilité dentures 0 et +





New!					New!					New!					New!				
L	A	E	Icon	€	L	A	E	Icon	€	L	A	E	Icon	€	L	A	E	Icon	€
mm	mm	mm		1 ud.	mm	mm	mm		1 ud.	mm	mm	mm		1 ud.	mm	mm	mm		1 ud.
1115	13	0,65	3	17,86	2240	13	0,65	3	28,54	2225	20	0,90	2	33,70	2140	27	0,90	2	33,38
1125				18,02	2242				28,58	2240				33,94	2145				33,45
1130				18,12	2390				29,70	2265				34,30	2150				33,52
1138				18,22	2440				30,33	2300				34,84	2155				33,62
1140				18,26	2490				30,95	2355				35,42	2360				36,09
1270				19,24	2500				31,08	2360				35,49	2375				36,31
1300				19,69	2550				31,69	2362				35,51	2400				36,69
1310				19,77	2580				32,07	2365				35,57	2410				36,84
1325				19,89	2735				33,30	2370				35,63	2440				37,29
1328				19,91	2800				33,93	2375				35,68	2445				37,37
1330				19,93	2840				34,39	2380				35,77	2450				37,44
1335				19,95	2845				34,45	2400				36,06	2455				37,51
1340				20,01	2890				35,03	2450				36,58	2459				37,56
1365				20,21	2900				35,13	2465				36,80	2460				37,57
1385				20,37	3115				37,16	2470				36,88	2465				37,64
1400				20,59	3200				38,03	2480				37,03	2470				37,71
1410				21,11	3355				39,61	2490				37,18	2480				37,83
1425				20,96	3370				39,78	2520				37,48	2485				37,91
1435				21,11	3430				40,50	2530				37,61	2500				38,15
1440				21,19	3600				42,51	2540				37,76	2515				38,38
1450				21,30	3830				44,39	2542				37,79	2520				38,45
1460				21,83	3857				44,70	2560				38,06	2535				38,55
1470				22,36	4180				46,91	2600				38,66	2540				38,58
1480				22,37	4400				49,27	2610				38,80	2550				38,74
1525				22,40	4440				49,66	2625				39,03	2560				38,87
1550				22,77	4600				51,50	2630				39,10	2565				38,94
1575				22,89	5140				57,55	2650				39,40	2570				39,01
1580				22,92	1710	20	0,90	2	26,51	2665				39,63	2580				39,15
1600				23,03	1735				26,89	2710				40,30	2600				39,40
1630				23,17	1740				26,97	2750				40,89	2615				39,63
1635				23,26	1750				27,12	2770				41,18	2625				39,78
1638				23,30	2000				29,10	2950				42,07	2655				39,98
1640				23,32	2005				29,96	2970				42,18	2660				40,05
1645				23,38	2010				30,82	3000				42,34	2680				40,46
1650				23,45	2020				30,96	3084				42,72	2700				40,71
1660				23,61	2035				31,34	3240				43,52	2710				40,87
1710				23,98	2037				31,40	3280				44,06	2715				40,94
1715				24,05	2040				31,43	3454				46,02	2720				41,03
1730				24,26	2058				31,74	3950				51,19	2725				41,09
1735				24,33	2060				31,75	4185				54,23	2730				41,16
1740				24,40	2070				31,86	4270				55,33	2735				41,24
1745				24,48	2075				31,93	4400				57,02	2740				41,31
1750				24,55	2080				32,00	4485				58,12	2750				41,36
1770				24,84	2085				32,05	4900				63,49	2755				41,43
1790				25,11	2090				32,12	5130				66,48	2759				43,30
1838				25,78	2095				32,18	5800				72,10	2760				41,49
1840				25,80	2100				32,23	2060	27	0,90	2	32,29	2765				41,55
1845				25,88	2110				32,37	2070				32,46	2770				41,63
1875				26,30	2115				32,44	2080				32,59	2795				41,89
2120				27,03	2120				32,52	2085				32,68	2800				41,96
2125				27,09	2130				32,64	2090				32,84	2820				42,27
2150				27,41	2140				32,75	2100				32,95	2825				42,34
2230				28,43	2215				33,56	2110				33,06	2830				42,41

Ref. **4223**

HOJA DE SIERRA DE CINTA HSSE 8% Co IZARFLEX

IZARFLEX HSSE 8% Co Band Saw Blade

Lame de scie à ruban HSSE 8% Co IZARFLEX

New!					New!					New!									
L	A	E		€	L	A	E		€	L	A	E		€	L	A	E		€
mm	mm	mm	1 ud.	1 ud.	mm	mm	mm	1 ud.	1 ud.	mm	mm	mm	1 ud.	1 ud.	mm	mm	mm	1 ud.	1 ud.
2835	27	0,90	2	42,48	3460	27	0,90	2	50,56	2600	34	1,10	1	45,22	5000	34	1,10	1	83,84
2840				42,54	3490				50,83	2620				45,56	5070				84,99
2845				42,61	3495				50,87	2630				45,73	5080				85,16
2847				42,65	3500				50,94	2970				51,64	5090				85,32
2850				42,70	3505				51,01	3505				60,69	5200				86,90
2855				42,77	3550				51,67	3530				61,13	5270				88,07
2860				42,84	3560				51,82	3634				62,93	5320				88,91
2865				42,89	3600				52,40	3655				63,29	5400				90,24
2870				42,93	3630				52,83	3660				63,38	5500				91,90
2884				43,07	3640				52,97	3851				66,68	5600				93,58
2900				43,28	3650				53,12	4020				68,54	5720				95,59
2910				43,46	3660				53,27	4100				69,91	5800				96,92
2915				43,51	3667				53,37	4115				70,13	6340				99,57
2920				43,58	3700				53,86	4120				70,20	6350				99,74
2925				43,65	3800				55,09	4130				70,38	6360				99,91
2927				43,68	3810				55,24	4160				70,89	7000				109,31
2940				43,81	3820				55,38	4180				71,23	7002				109,32
2945				43,89	3830				55,52	4250				72,42	7010				109,47
2950				43,98	3851				55,83	4260				72,59	8730				136,33
2960				44,12	3853				55,85	4300				73,28	4115	41	1,30	1	100,08
2965				44,20	3900				56,54	4335				73,54	4500				109,44
2985				44,39	3930				56,97	4340				73,62	4650				112,46
3000				44,62	3950				57,25	4350				73,79	4670				112,95
3010				44,77	4000				57,98	4370				74,14	4930				118,30
3015				44,84	4050				58,45	4400				74,65	5000				119,97
3020				44,90	4079				58,72	4420				74,97	5090				122,13
3025				44,98	4090				58,88	4440				75,32	5334				127,99
3035				45,14	4100				59,02	4470				75,83	5400				129,58
3050				45,36	4115				59,24	4520				76,32	5450				130,76
3084				45,68	4270				59,96	4570				77,15	5500				131,97
3090				45,79	4310				60,14	4600				77,66	5600				134,37
3100				45,95	4470				60,87	4610				77,83	5700				136,11
3110				46,07	4500				61,21	4640				78,34	5800				137,85
3120				46,22	4600				62,57	4670				78,85	5920				140,71
3140				46,45	4870				65,81	4720				79,51	6192				147,19
3150				46,59	4875				65,87	4750				79,90	6500				152,80
3160				46,74	4900				66,21	4770				80,23	6600				155,14
3175				46,93	4960				66,93	4780				80,41	6675				156,91
3180				47,01	5035				67,87	4800				80,74	6775				159,25
3200				47,30	5090				68,57	4900				82,15	6800				159,84
3215				47,51	5430				72,81	4930				82,65	6990				164,32
3220				47,59	5445				73,01	4970				83,34	7400				173,84
3230				47,74	5600				77,45	4990				83,68	7470				175,49
3250				48,03	6200				84,09						7880				185,12
3270				48,14	6500				88,15										
3280				48,20	7400				97,34										
3285				48,23															
3300				48,44															
3310				48,58															
3320				48,73															
3345				49,10															
3350				49,18															
3352				49,21															
3365				49,41															
3370				49,48															
3378				49,59															
3380				49,61															
3400				49,87															
3420				50,12															
3430				50,25															
3435				50,33															
3440				50,41															

Tipo Dentado (TZ) / Teeth Type (TZ) / Type Denture (TZ)

A x E	TPI									
	2	2-3	3	3-4	4	4-6	5-8	6-10	8-12	10-14
13 x 0,65								S	S	S
20 x 0,90			K		K	K	S	S	S	S
27 x 0,90	K		K	K	K	K	S	S	S	S
34 x 1,10		K	K	K		K	S	S	S	
41 x 1,30		K		K		K				

Rollos sin Soldadura
Rolls without Welding
Rouleaux non soudées

L	A	E	8% Co
mm	mm	mm	€
30500	13	0,65	310,46
100000	20	0,90	1117,66
100000	27	0,90	1188,50
100000	34	1,10	1404,95
75000	41	1,30	1534,83



Unidades pedido mínimo
Minimum order units
Unités commande minimale

Ejemplo Pedido / Order Example / Exemple Commande

Ref. 4223 + L 2450 + A 27 + E 0,90 + TPI 6-10 + TZ S

Ref. **4228**

HOJA DE SIERRA DE CINTA HSSE 8% Co + 4% Cr IZARPLUS

IZARPLUS HSSE 8% Co + 4% Cr Band Saw Blade

Lame de scie à ruban HSSE 8% Co + 4% Cr IZARPLUS

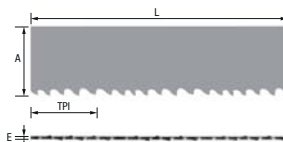

Aceros <850 N/mm ² Steel / Aciers	Aceros <1000 N/mm ² Steel / Aciers	Fundición Cast Iron Fonte	INOX Stainless Steel Acier INOX
Cobre Copper Cuivre	Aluminio Aluminium	Plásticos Plastics Plastiques	

Especial Perfiles. Dentado variable 0° adecuado para perfiles y tareas de corte en serie, susceptibles de vibraciones.

Special Profiles. Variable tooth pitch 0° for profiles and bundle sawing tasks, susceptible of vibrations.

Spécial profils. Denture variable 0° convenable pour profils et travaux de coupe en paquet, susceptibles des vibrations.

New!				
L	A	E		€
mm	mm	mm	1 ud.	
1100	13	0,65	3	22,53
1130				23,14
1138				23,31
1140				23,34
1300				25,67
1310				25,87
1325				26,02
1330				26,14
1335				26,22
1340				26,32
1350				26,50
1368				26,85
1400				27,18
1425				27,48
1430				27,52
1435				27,64
1440				27,73
1450				28,47
1460				28,67
1470				28,86
1500				29,19
1550				29,76
1575				30,24
1580				30,34
1605				30,46
1635				30,58
1638				30,62
1640				30,65
1645				30,75
1650				30,85
1680				31,41
1732				31,99
1735				32,04
1740				32,09
1750				32,25
1974				36,39
2180				40,15
2240				41,25
2265				41,73
2900				53,41
4180				68,89

New!				
L	A	E		€
mm	mm	mm	1 ud.	
1125	13	0,90	3	23,04
1140				23,34
1325				26,02
1330				26,13
1335				26,22
1375				26,98
1470				28,86
1485				29,15
1638				30,62
1640				30,64
1650				30,85
1735				32,04
1750				32,25
1840				33,93

New!				
L	A	E		€
mm	mm	mm	1 ud.	
1735	20	0,90	2	32,04
2000				34,36
2010				34,53
2035				34,78
2045				34,95
2060				35,22
2070				35,36
2080				35,50
2082				35,52
2085				35,58
2090				35,65
2100				35,80
2110				35,94
2130				36,20
2140				36,38
2150				36,54
2265				38,16
2360				39,50
2362				39,55
2370				39,65
2375				39,71
2400				40,07
2465				41,00
2480				41,25
2500				41,50
2520				41,76
2530				41,92
2600				43,09
2825				45,69
2960				47,88
2980				48,20

New!				
L	A	E		€
mm	mm	mm	1 ud.	
2080	27	0,90	2	40,09
2100				40,12
2110				40,13
2145				40,19
2150				40,19
2360				40,65
2375				40,66
2400				40,69
2430				40,73
2435				40,74
2440				40,74
2445				40,75
2450				40,84
2455				40,87
2460				40,89
2470				41,42
2480				41,94
2490				41,99
2500				42,02
2520				42,07
2535				42,13
2550				42,19
2560				42,30
2565				42,35
2570				42,44
2600				42,90
2640				43,14
2655				43,23
2660				43,31
2680				43,64
2700				44,34
2710				44,51
2715				44,51
2720				44,51
2730				44,55
2740				44,57
2745				44,60
2750				44,64
2755				44,74
2760				44,79
2765				44,84
2780				45,08
2805				45,39
2820				45,62
2825				45,69
2830				45,74
2835				45,75

Ref. **4228**

HOJA DE SIERRA DE CINTA HSSE 8% Co + 4% Cr IZARPLUS

IZARPLUS HSSE 8% Co + 4% Cr Band Saw Blade

Lame de scie à ruban HSSE 8% Co + 4% Cr IZARPLUS

New!					New!					New!					New!				
L	A	E	€	1 ud.	L	A	E	€	1 ud.	L	A	E	€	1 ud.	L	A	E	€	1 ud.
mm	mm	mm			mm	mm	mm			mm	mm	mm			mm	mm	mm		
2840	27	0,90	2	45,76	3352	27	0,90	2	52,76	3320	34	1,10	1	68,90	4115	41	1,30	1	117,50
2845				45,77	3370				53,05	3505				72,74	4500				127,49
2850				45,84	3400				54,11	3660				74,89	4640				131,46
2870				45,85	3420				54,22	3800				77,76	4930				138,99
2885				45,86	3440				54,53	3820				78,16	5000				140,96
2900				45,86	3454				54,76	3860				78,98	5040				142,09
2910				46,02	3485				54,78	3920				80,17	5090				143,49
2920				46,12	3505				54,79	3950				80,79	5265				148,06
2925				46,23	3560				55,19	4020				82,22	5300				149,06
2927				46,25	3630				55,45	4030				82,42	5350				150,47
2950				46,58	3660				55,89	4100				83,86	5450				152,99
2965				46,83	3670				56,05	4120				84,28	5700				159,32
3000				47,41	3800				56,79	4250				86,55	5920				165,48
3010				47,56	3810				56,95	4335				88,29	6175				172,60
3025				47,80	3820				57,09	4380				89,23	6300				175,61
3035				47,96	3830				57,23	4400				89,63	6400				178,40
3080				50,25	3835				57,31	4420				90,04	6585				183,17
3090				50,42	3850				57,54	4450				90,43	6775				188,21
3100				50,58	3851				57,55	4470				90,84	6800				188,90
3110				50,60	3857				57,65	4520				91,75	6900				191,54
3120				50,63	3900				58,29	4570				92,69	7470				206,68
3135				50,67	3930				58,74	4610				93,39	7880				218,03
3140				50,68	4090				60,72	4620				93,60	8200				226,88
3150				50,70	4115				61,09	4640				94,00					
3160				50,73	4230				62,78	4780				96,63					
3180				50,77	4250				63,08	4800				97,04					
3200				51,09	4280				63,54	4930				99,37					
3270				51,47	4500				66,80	4970				100,18					
3300				51,94	4600				68,29	4990				100,55					
3320				52,25	4820				76,32	5040				101,42					
3335				52,50	4870				77,10	5050				101,62					
3340				52,57	4880				77,26	5090				102,28					
3345				52,66	5030				79,64	5200				104,49					
3350				52,73	5200				82,34	5270				105,80					
										5300				106,36					
										6350				120,01					
										6500				122,66					
										6550				123,60					
										7000				131,62					
										7550				141,41					

Tipo Dentado (TZ) / Teeth Type (TZ) / Type Denture (TZ)

A x E	TPI					
	3-4	4-6	5-8	6-10	8-12	10-14
13 x 0,65				S	S	S
13 x 0,90				S	S	S
20 x 0,90		S	S	S	S	S
27 x 0,90	S	S	S	S	S	S
34 x 1,10	S	S	S	S	S	
41 x 1,30	S	S	S	S		

Rollos sin Soldadura / Rolls without Welding / Rouleaux non soudées

L	A	E	8% Co	L	A	E	8% Co
mm	mm	mm	€	mm	mm	mm	€
30500	13	0,65	390,21	100000	27	0,90	1386,45
123000			1572,39	134000			1908,51
30500	13	0,90	390,21	100000	34	1,10	1702,49
100000	20	0,90	1334,02	75000	41	1,30	1812,58



Unidades pedido mínimo
Minimum order units
Unités commande minimale

Ejemplo Pedido / Order Example / Exemple Commande

Ref. 4228 + L 2080 + A 27 + E 0,90 + TPI 8-12 + TZ S

Ref. **4229**

HOJA DE SIERRA DE CINTA HSSE 8% Co + 4% Cr IZARPLUS

IZARPLUS HSSE 8% Co + 4% Cr Band Saw Blade

Lame de scie à ruban HSSE 8% Co + 4% Cr IZARPLUS

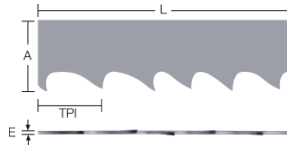

**HSSE
8% Co**

4% Cr



**Aceros
<850 N/mm²
Steel / Aciers**

**Aceros
<1000 N/mm²
Steel / Aciers**

**INOX
Stainless Steel
Acier INOX**

**Cobre
Copper
Cuivre**

**Aluminio
Aluminium**

**Plásticos
Plastics
Plastiques**

Especial Macizos. Dentado variable 10°. Mayores rendimientos de corte, ideal para el corte de piezas macizas grandes.

Special Solid Pieces. Variable tooth pitch 10°. Higher cutting performance, suitable to cut big solid pieces.

Spécial pièces pleins. Denture variable 10°. Rendements de coupe supérieurs, convenable pour la coupe de grandes pièces pleins.

New!

L mm	A mm	E mm	€ 1 ud.
2080	27	0,90	40,09
2150			40,20
2450			40,84
2455			40,86
2459			40,88
2460			40,89
2480			41,94
2550			42,19
2565			42,38
2570			42,44
2590			42,74
2600			42,90
2680			43,64
2700			44,34
2710			44,51
2720			44,56
2750			44,64
2755			44,74
2760			44,79
2765			44,84
2800			45,29
2825			45,69
2835			45,74
2845			45,77
2855			45,93
2910			46,02
2925			46,23
2950			46,58
3000			47,41
3010			47,56
3025			47,80
3035			47,96
3100			50,58
3105			50,59

New!

L mm	A mm	E mm	€ 1 ud.
3120	27	0,90	50,64
3140			50,69
3150			50,70
3160			50,72
3180			50,77
3200			51,12
3222			51,45
3240			51,74
3270			51,84
3300			51,94
3320			52,25
3345			52,66
3350			52,73
3352			52,76
3400			53,89
3420			54,22
3445			54,61
3500			55,32
3505			55,41
3550			55,56
3640			55,83
3660			55,89
3770			56,36
3800			56,79
3810			56,94
3820			57,09
3830			57,24
3900			58,29
3930			58,74
4090			60,72
4110			61,02
4115			61,09
4310			66,84
4500			69,56
4800			74,19

New!

L mm	A mm	E mm	€ 1 ud.
3350	34	1,10	66,52
3505			72,74
3820			78,16
4020			82,25
4100			83,89
4120			84,27
4130			84,48
4160			85,09
4210			86,11
4220			86,32
4250			86,92
4335			88,29
4420			89,72
4440			90,13
4450			90,33
4470			90,74
4520			91,76
4530			91,95
4570			92,69
4640			94,12
4720			95,41
4770			96,41
4780			96,63
4860			98,25
4865			98,33
4970			100,18
4990			100,55
5000			100,77
5090			102,58
5156			103,61
5200			104,49
5270			105,76
5300			106,36

New!

L mm	A mm	E mm	€ 1 ud.
4115	41	1,30	117,50
4500			127,49
4640			131,46
4650			131,73
4700			133,15
4900			138,15
4930			138,99
5040			142,08
5080			143,21
5090			143,49
5340			150,19
5350			150,47
5450			153,27
5800			162,29
5890			164,65
5920			165,48
6500			180,80
6585			183,17
6675			185,67
6775			188,21
6800			188,90
6900			191,53
7470			206,68
8200			215,31
8400			220,47
5800	54	1,60	200,58
6040			212,47
6200			220,38
6270			222,74
6500			230,45
7140			252,00
7200			254,01
7310			257,89
7460			262,72
7545			265,52
7600			267,45
8900			320,45

Rollos sin Soldadura
Rolls without Welding
Rouleaux non soudées

Tipo Dentado (TZ) / Teeth Type (TZ) / Type Denture (TZ)

A x E	TPI				
	1,4-2	2-3	3-4	4-6	5-8
27 x 0,90		K	K	K	K
34 x 1,10	K	K	K	K	K
41 x 1,30	K	K	K	K	K
54 x 1,30	K	K	K	K	



Unidades pedido mínimo
Minimum order units
Unités commande minimale

L mm	A mm	E mm	8% Co €
100000	20	0,90	1334,02
100000	27	0,90	1386,45
134000			1908,51
100000	34	1,10	1702,49
75000	41	1,30	1812,65

Ejemplo Pedido / Order Example / Exemple Commande

Ref. 4229 + L 2080 + A 27 + E 0,90 + TPI 5-8 + TZ K

Ref. **1994**

ARCO SIERRA

Hacksaw Frame
Monture scie

¡Hoja de Sierra de Regalo!
Free Hacksaw Blade!
Lame scie **cadeau!**



Arco ergonómico de aleación de aluminio. Corte recto, vertical y horizontal. Hoja sierra regalo art. 67592: TPI 24

Ergonomic Aluminium alloyed hack saw frame. Straight cut, both vertical and horizontal. Free hacksaw blade art. 67592: TPI 24

Monture ergonomique de alliage aluminium. Coupe droite et horizontale. Lame scie cadeau art. 67592 : TPI 24



Nº Art.	€
62289	9,67

Ref. **1999**

HOJA SIERRA

Hacksaw Blade
Lame scie

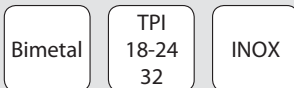

Aceros <850 N/mm² Steel / Aciers
Aceros <1000 N/mm² Steel / Aciers
INOX Stainless Steel Acier INOX

TPI	L mm	📦	Nº Art.	€ 1 ud.
18	300	100	13856	1,46
24	300	20	25355	1,67
24	300	100	25387	1,46
32	300	100	28767	1,46

Ref. **1997**

HOJA SIERRA

Hacksaw Blade
Lame scie

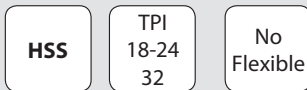

Aceros <850 N/mm² Steel / Aciers
Aceros <1000 N/mm² Steel / Aciers

TPI	L mm	📦	Nº Art.	€ 1 ud.
18	300	100	34553	1,24
24	300	20	34552	1,45
24	300	100	34554	1,24
32	300	100	34555	1,24

Ref. **1996**

HOJA SIERRA

Hacksaw Blade
Lame scie



Mod. 1



Mod. 2

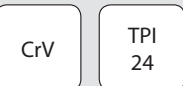

Mod.	Usos / Use / Usage	TPI	L mm	📦	Nº Art.	€ 1 ud.
1	Metal	24	300	50	17139	0,99
2	Metal-Madera/Wood/Bois	24	300	50	67592	0,55

HERRAMIENTAS TORNEADO

Brazed Turning Tools

Outils de tour

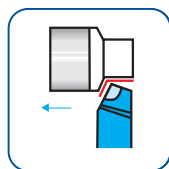
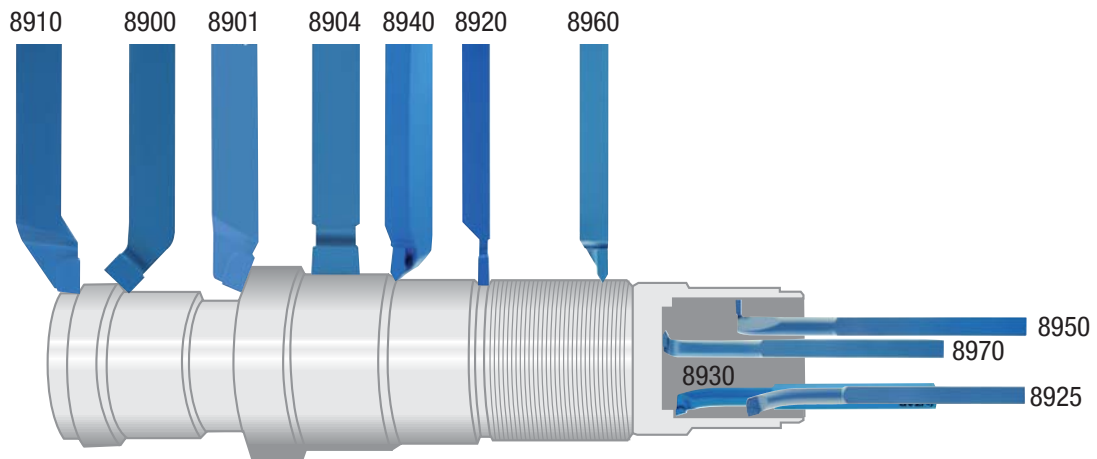

ISO 1 - 8901

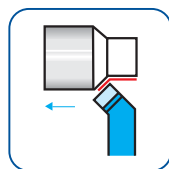

ISO 2 - 8900

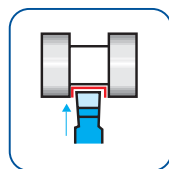

ISO 4 - 8904

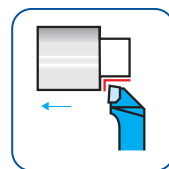

ISO 6 - 8910

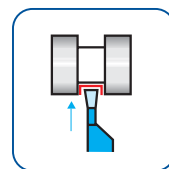

ISO 7 - 8920

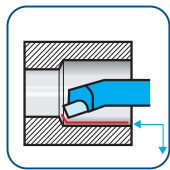

ISO 8 - 8925

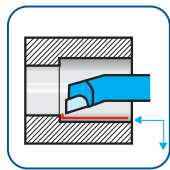

ISO 9 - 8930

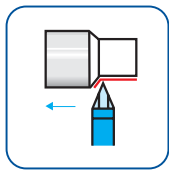

ISO 10 - 8940

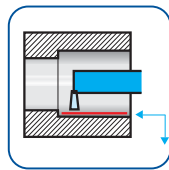

ISO 11 - 8950

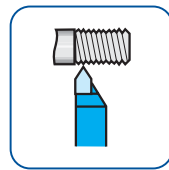

ISO 12 - 8960

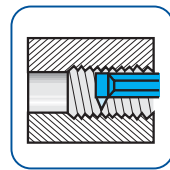

ISO 13 - 8970

Calidad P20

Especialmente destinada a mecanizados de gran precisión y semi-acabado en aceros al carbono y aleados, a grandes velocidades de corte y avances moderados.

P20 Quality

Specially destined for high precision and semi-finishing machining of carbon & alloy steels, at high cutting speeds and moderate feeds.

Qualité P20

Notamment pour usinages haute précision et semi-finition en aciers au carbone et alliés, a hautes vitesses de coupe et avances modérés.

Calidad M20

Especial para acabado y desbaste suave de aceros, aceros al manganeso, fundición y metales resistentes al calor o no ferrosos, a velocidades de corte medias o bajas.

M20 Quality

Special for finishing and soft roughing of steels, manganese-steels, cast iron and heat-resistant or non-ferrous materials, at medium or low cutting speed.

Qualité M20

Spécial finition et ébauche tendre d'aciers, aciers au manganèse, fonte et aciers résistants au chaud et non ferreux à faibles où moyennes vitesses de coupe.

Calidad K10

Especial para mecanizados de gran precisión y semi-acabado en fundición, aceros aleados, materiales de viruta corta y no ferrosos.

K10 Quality

Special for high precision and semi-finishing machining of cast iron, alloyed steels, short chipping and non-ferrous materials.

Qualité K10

Spéciale pour usinage d'haute précision et semi-finition fonte, alliages aciers, aciers copeaux courts et non ferreux.

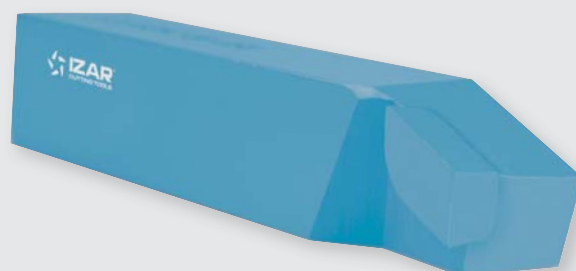

Ref. **8901**

HERRAMIENTA TORNEADO PLACA SOLDADA CILINDRADO 70°

70° Straight Brazed Turning Tool

Outil de tour plaquette soudé cylindrage 70°

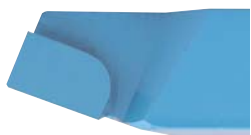

DIN
4971

ISO
1



Aceros
<850 N/mm²
Steel / Aciers

Aceros
<1000 N/mm²
Steel / Aciers

Fundición
Cast Iron
Fonte

Aceros
<1300 N/mm²
Steel / Aciers

INOX
Stainless Steel
Acier INOX

Cobre
Copper
Cuivre

Fundición
Cast Iron
Fonte

Aluminio
Aluminium

h mm	b mm	L mm	R/L	n mm	r mm	Calidad Quality / Qualité P-20		Calidad Quality / Qualité K-10	
						N° Art.	€	N° Art.	€
10	10	90	- L	4	0,2	55888	7,47	55889	7,47
10	10	90	- R	4	0,2	55893	7,47	55891	7,47
12	12	100	- L	5	0,4	55894	8,03	55897	8,03
12	12	100	- R	5	0,4	55896	8,03	55899	8,03
16	16	110	- L	6	0,4	55903	10,10	55905	10,10
16	16	110	- R	6	0,4	55904	10,10	55906	10,10
20	20	125	- L	8	0,8	55911	13,79	55913	13,79
20	20	125	- R	8	0,8	55912	13,79	55914	13,79
25	25	140	- L	10	0,8	55917	20,40	55919	20,40
25	25	140	- R	10	0,8	55918	20,40	55920	20,40

Ref. **8900**

HERRAMIENTA TORNEADO PLACA SOLDADA ESCUADRADO 45°

45° Bent Brazed Turning Tool

Outil de tour plaquette soudé décolletage 45°

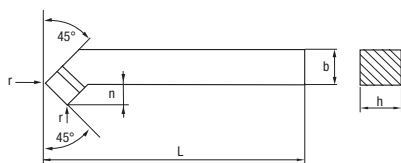

DIN
4972

ISO
2



Aceros
<850 N/mm²
Steel / Aciers

Aceros
<1000 N/mm²
Steel / Aciers

Fundición
Cast Iron
Fonte

Aceros
<1300 N/mm²
Steel / Aciers

INOX
Stainless Steel
Acier INOX

Cobre
Copper
Cuivre

Fundición
Cast Iron
Fonte

INOX
Stainless Steel
Acier INOX

Aluminio
Aluminium

h mm	b mm	L mm	R/L	n mm	r mm	Calidad Quality / Qualité P-20		Calidad Quality / Qualité M-20		Calidad Quality / Qualité K-10	
						N° Art.	€	N° Art.	€	N° Art.	€
12	12	100	- L	7	0,4	13586	8,92	56073	8,92	29179	8,92
12	12	100	- R	7	0,4	13585	8,92	56074	8,92	29153	8,92
16	16	110	- L	8	0,4	13589	11,12	56076	11,12	29181	11,12
16	16	110	- R	8	0,4	13588	11,12	56077	11,12	18258	11,12
20	20	125	- L	10	0,8	13592	14,12	56078	14,12	13051	14,12
20	20	125	- R	10	0,8	13591	14,12	56079	14,12	28343	14,12
25	25	140	- L	12	0,8	13597	19,99	56080	19,99	29182	19,99
25	25	140	- R	12	0,8	13594	19,99	56082	19,99	26003	19,99

Ref. **8904**

HERRAMIENTA TORNEADO PLACA SOLDADA RANURADO EXTERIOR

Wide Face Square Nose Brazed Turning Tool

Outil de tour plaquette soudé rainurage extérieur

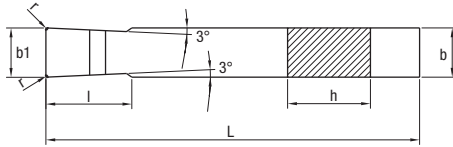
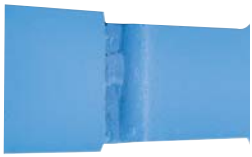

DIN
4976

ISO
4



Aceros <850 N/mm ² Steel / Aciers	Aceros <1000 N/mm ² Steel / Aciers	Fundición Cast Iron Fonte
Aceros <1300 N/mm ² Steel / Aciers	INOX Stainless Steel Acier INOX	Cobre Copper Cuivre
Fundición Cast Iron Fonte		Aluminio Aluminium

h mm	b mm	L mm	r mm	l mm	b1 mm	Calidad Quality / Qualité P-20		Calidad Quality / Qualité K-10	
						N° Art.	€	N° Art.	€
20	12	125	0,4	20	12	55924	10,86	55926	10,86
25	16	140	0,4	25	16	55928	15,12	55932	15,12
32	20	170	0,4	32	20	55936	22,68	55938	22,68

Ref. **8910**

HERRAMIENTA TORNEADO PLACA SOLDADA ESCUADRADO 90°

90° Offset Side Brazed Turning Tool

Outil de tour plaquette soudé décolletage 90°

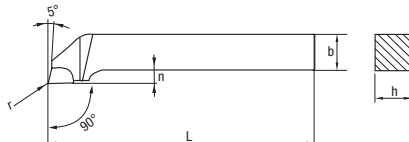
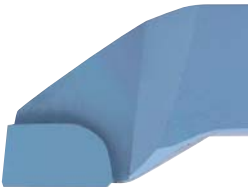

DIN
4980

ISO
6



Aceros <850 N/mm ² Steel / Aciers	Aceros <1000 N/mm ² Steel / Aciers	Fundición Cast Iron Fonte
Aceros <1300 N/mm ² Steel / Aciers	INOX Stainless Steel Acier INOX	Cobre Copper Cuivre
Fundición Cast Iron Fonte	INOX Stainless Steel Acier INOX	Aluminio Aluminium

h mm	b mm	L mm	R/L	n mm	r mm	Calidad Quality / Qualité P-20		Calidad Quality / Qualité M-20		Calidad Quality / Qualité K-10	
						N° Art.	€	N° Art.	€	N° Art.	€
10	10	090	- L	4	0,2	13601	8,08	56083	8,08	29183	8,08
10	10	090	- R	4	0,2	13600	8,08	56085	8,08	26488	8,08
12	12	100	- L	5	0,4	13604	8,96	56086	8,96	29185	8,96
12	12	100	- R	5	0,4	13603	8,96	56088	8,96	26707	8,96
16	16	110	- L	6	0,4	13607	10,87	56089	10,87	13058	10,87
16	16	110	- R	6	0,4	13606	10,87	56091	10,87	27460	10,87
20	20	125	- L	8	0,8	13612	14,47	56092	14,47	10825	14,47
20	20	125	- R	8	0,8	13609	14,47	56093	14,47	27461	14,47
25	25	140	- L	10	0,8	13616	21,07	56094	21,07	17090	21,07
25	25	140	- R	10	0,8	13615	21,07	56095	21,07	11181	21,07

Ref. **8920**

HERRAMIENTA TORNEADO PLACA SOLDADA TRONZADO

Parting Brazed Turning Tool
Outil de tour plaquette soudé tronçonnage

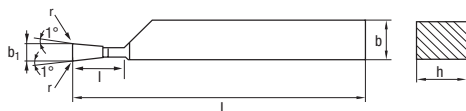

DIN
4981

ISO
7



Aceros <850 N/mm ² Steel / Aciers	Aceros <1000 N/mm ² Steel / Aciers
Aceros <1300 N/mm ² Steel / Aciers	INOX Stainless Steel Acier INOX
Fundición Cast Iron Fonte	

INOX
Stainless Steel
Acier INOX

Fundición Cast Iron Fonte
Cobre Copper Cuivre
Aluminio Aluminium

h mm	b mm	L mm	R/L	r mm	l mm	b1 mm	Calidad Quality / Qualité P-20		Calidad Quality / Qualité M-20		Calidad Quality / Qualité K-10	
							N° Art.	€	N° Art.	€	N° Art.	€
12	8	100	- L	0,2	12	3	13619	8,38			28344	8,38
12	8	100	- R	0,2	12	3	13618	8,38	56098	8,38	27519	8,38
16	10	110	- L	0,2	14	4	13622	9,14			29186	9,14
16	10	110	- R	0,2	14	4	13621	9,14	56100	9,14	19523	9,14
20	12	125	- L	0,2	16	5	13625	10,57			29187	10,57
20	12	125	- R	0,2	16	5	13624	10,57	56102	10,57	22685	10,57
25	16	140	- L	0,3	20	6	13628	14,01			29189	14,01
25	16	140	- R	0,3	20	6	13627	14,01	56104	14,01	29188	14,01

Ref. **8925**

HERRAMIENTA TORNEADO PLACA SOLDADA MANDRINADO

Boring Straight Brazed Turning Tool
Outil de tour plaquette soudé alésage

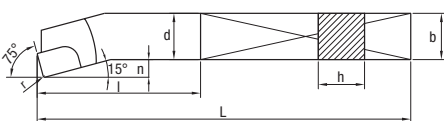

DIN
4973

ISO
8

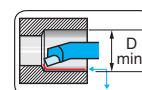

Aceros <850 N/mm ² Steel / Aciers	Aceros <1000 N/mm ² Steel / Aciers
Aceros <1300 N/mm ² Steel / Aciers	INOX Stainless Steel Acier INOX
Fundición Cast Iron Fonte	

Fundición Cast Iron Fonte
Cobre Copper Cuivre
Aluminio Aluminium

h mm	b mm	L mm	n mm	r mm	D min. mm	Calidad Quality / Qualité P-20		Calidad Quality / Qualité K-10	
						N° Art.	€	N° Art.	€
8	8	125	3	0,4	14	38218	10,69	38220	10,69
10	10	150	4	0,4	18	38222	11,01	38224	11,01
12	12	180	5	0,4	21	38227	11,32	38391	11,32
16	16	210	6	0,4	27	38393	12,71	38395	12,71
20	20	250	8	0,4	34	38397	16,51	38399	16,51
25	25	300	10	0,8	43	38401	25,99	38403	25,99

Ref. **8930**

HERRAMIENTA TORNEADO PLACA SOLDADA CILINDRADO INTERIOR

Internal Sharped Brazed Turning Tool
Outil de tour plaquette soudé cylindrage intérieur

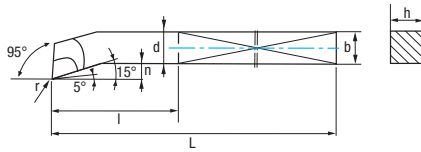

DIN
4974

ISO
9

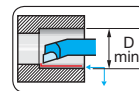

Aceros <850 N/mm ² Steel / Aciers	Aceros <1000 N/mm ² Steel / Aciers
Aceros <1300 N/mm ² Steel / Aciers	INOX Stainless Steel Acier INOX
Fundición Cast Iron Fonte	

INOX
Stainless Steel
Acier INOX

Fundición Cast Iron Fonte
Cobre Copper Cuivre
Aluminio Aluminium

h mm	b mm	L mm	d mm	n mm	r mm	l mm	D min. mm	Calidad Quality / Qualité P-20		Calidad Quality / Qualité M-20		Calidad Quality / Qualité K-10	
								N° Art.	€	N° Art.	€	N° Art.	€
8	8	125	8	3	0,2	40	14	13630	11,01	56114	11,01	14971	11,01
10	10	150	10	4	0,2	50	18	13631	10,87	56115	10,87	27462	10,87
12	12	180	12	5	0,2	63	21	13633	11,53	56116	11,53	27464	11,53
16	16	210	16	6	0,2	80	27	13634	13,74	56117	13,74	11152	13,74
20	20	250	20	8	0,4	100	34	13636	17,37	56118	17,37	11754	17,37
25	25	300	25	10	0,4	125	43	13639	26,38	56119	26,38	27518	26,38
32	32	355	32	12	0,8	160	52	13642	46,42	56121	46,42	13896	46,42

Ref. **8940**

HERRAMIENTA TORNEADO PLACA SOLDADA CILINDRADO RECTO

Sharped Straight Brazed Turning Tool
Outil de tour plaquette soudé cylindrage droit

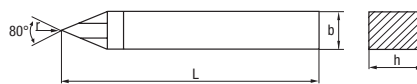
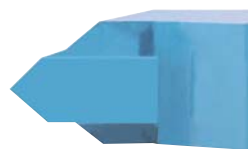

DIN
4975

ISO
10



Aceros <850 N/mm ² Steel / Aciers	Aceros <1000 N/mm ² Steel / Aciers
Aceros <1300 N/mm ² Steel / Aciers	INOX Stainless Steel Acier INOX
Fundición Cast Iron Fonte	

Fundición Cast Iron Fonte
Cobre Copper Cuivre
Aluminio Aluminium

h mm	b mm	L mm	r mm	Calidad Quality / Qualité P-20		Calidad Quality / Qualité K-10	
				N° Art.	€	N° Art.	€
16	10	110	0,2	13645	8,22	29190	8,22
20	12	125	0,4	13646	9,52	29191	9,52
25	16	140	0,4	13648	12,15	29192	12,15

Ref. **8950**

HERRAMIENTA TORNEADO PLACA SOLDADA RANURADO INTERIOR

Internal Undercutting Brazed Turning Tool
Outil de tour plaquette soudé rainurado intérieur

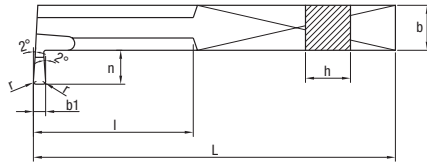

DIN
263

ISO
11

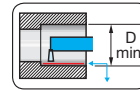

Aceros <850 N/mm ² Steel / Aciers	Aceros <1000 N/mm ² Steel / Aciers	Fundición Cast Iron Fonte
Aceros <1300 N/mm ² Steel / Aciers	INOX Stainless Steel Acier INOX	Cobre Copper Cuivre
Fundición Cast Iron Fonte		Aluminio Aluminium

h mm	b mm	L mm	n mm	r mm	b1 mm	D min. mm	Calidad Quality / Qualité P-20		Calidad Quality / Qualité K-10	
							N° Art.	€	N° Art.	€
12	12	180	10	0,2	4	32	38405	17,97	38407	17,97
16	16	210	12	0,2	5	40	38409	22,46	38411	22,46
20	20	250	16	0,4	6	50	38413	28,36	38415	28,36
25	25	300	20	0,4	8	63	38417	35,64	38419	35,64

Ref. **8960**

HERRAMIENTA TORNEADO PLACA SOLDADA ROSCADO EXTERIOR

External Threading Brazed Turning Tool
Outil de tour plaquette soudé taraudage extérieur



DIN
282

ISO
12



Aceros <850 N/mm ² Steel / Aciers	Aceros <1000 N/mm ² Steel / Aciers	Fundición Cast Iron Fonte
Aceros <1300 N/mm ² Steel / Aciers	INOX Stainless Steel Acier INOX	Cobre Copper Cuivre
Fundición Cast Iron Fonte		Aluminio Aluminium

h mm	b mm	L mm	R/L	n mm	Calidad Quality / Qualité P-20		Calidad Quality / Qualité K-10	
					N° Art.	€	N° Art.	€
16	10	110	- L	2,0	38422	9,98	38424	9,98
16	10	110	- R	2,0	38421	9,98	38423	9,98
20	12	125	- L	2,5	38426	11,70	38428	11,70
20	12	125	- R	2,5	38425	11,70	38427	11,70
25	16	140	- L	3,0	38430	15,23	38432	15,23
25	16	140	- R	3,0	38429	15,23	38431	15,23

Ref. **8970**

HERRAMIENTA TORNEADO PLACA SOLDADA ROSCADO INTERIOR

Internal Threading Brazed Turning Tool

Outil de tour plaquette soudé taraudage intérieur

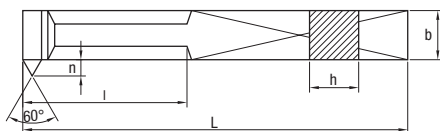

DIN
283

ISO
13

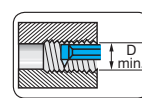

Aceros <850 N/mm ² Steel / Aciers	Aceros <1000 N/mm ² Steel / Aciers	Fundición Cast Iron Fonte
Aceros <1300 N/mm ² Steel / Aciers	INOX Stainless Steel Acier INOX	Cobre Copper Cuivre
Fundición Cast Iron Fonte		Aluminio Aluminium

h mm	b mm	L mm	R/L	n mm	D min. mm	Calidad Quality / Qualité P-20		Calidad Quality / Qualité K-10	
						N° Art.	€	N° Art.	€
10	10	150	- L	5	22	38434	17,13	38436	17,13
10	10	150	- R	5	22	38433	17,13	38435	17,13
12	12	180	- L	6	24	38438	17,44	38440	17,44
12	12	180	- R	6	24	38437	17,44	38439	17,44
16	16	210	- L	8	32	38442	22,92	38444	22,92
16	16	210	- R	8	32	38441	22,92	38443	22,92
20	20	250	- L	10	40	38446	27,21	38448	27,21
20	20	250	- R	10	40	38445	27,21	38447	27,21
25	25	300	- L	12	49	38450	38,59	38452	38,59
25	25	300	- R	12	49	38449	38,59	38451	38,59

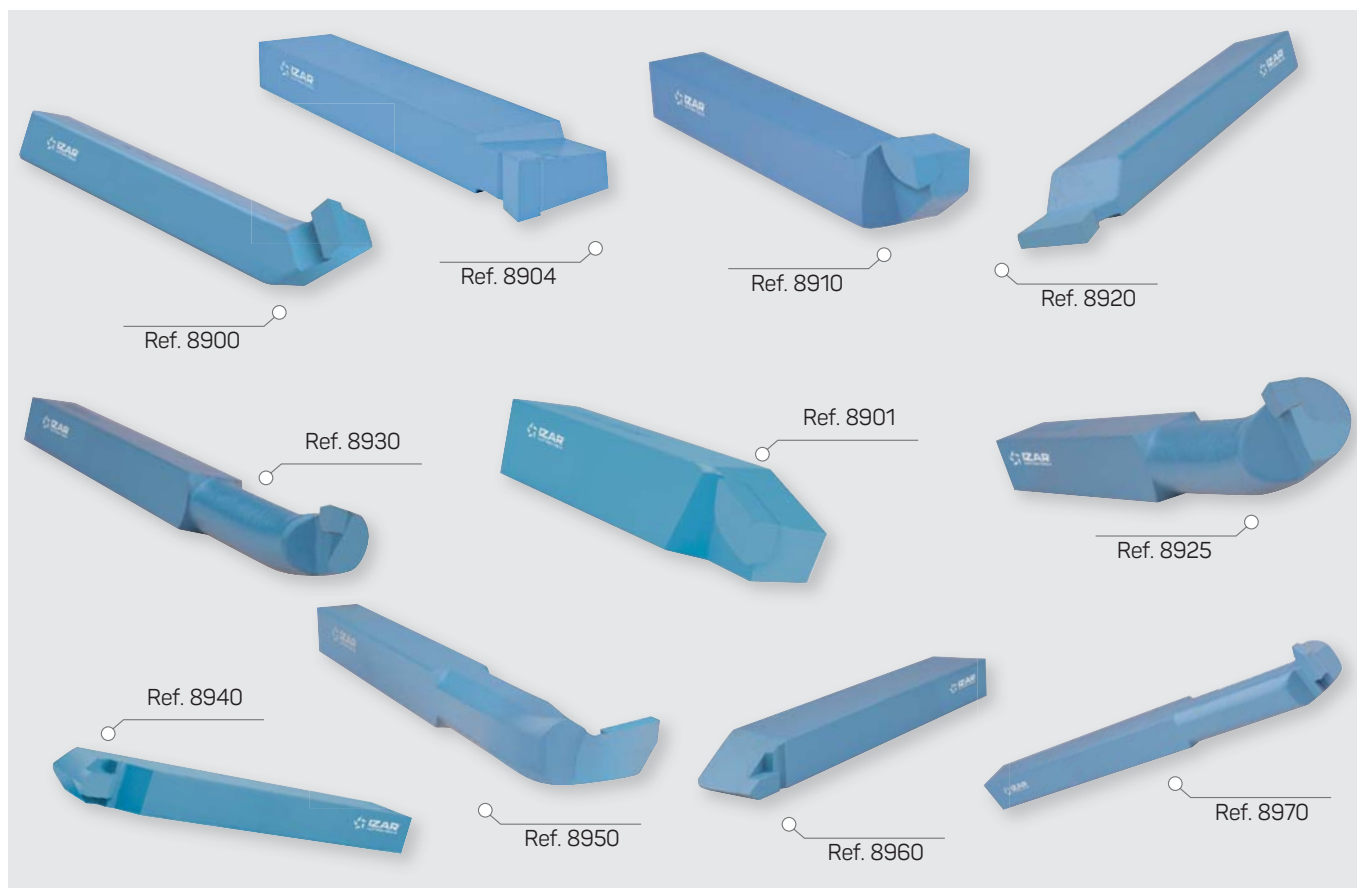

Ref. **8990**

CUCHILLA CUADRADA TORNEADO

Square Turning Blade
Outil de tour carré

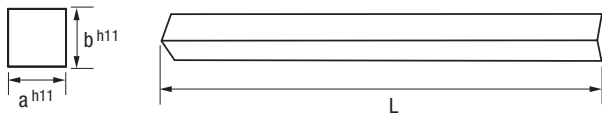

Cuchillas Torno
Turning Tools
Outils de tour

HSSE
10%Co

DIN
4964B



a mm	b mm	L mm	Nº Art.	€
6	x 6	x 100	35462	7,11
6	x 6	x 160	35463	10,61
6	x 6	x 200	35464	13,19
8	x 8	x 100	35465	11,95
8	x 8	x 160	35466	16,47
8	x 8	x 200	35467	19,65
10	x 10	x 100	35468	17,08
10	x 10	x 160	35469	25,38
10	x 10	x 200	35470	32,55
12	x 12	x 100	35471	20,85
12	x 12	x 160	35472	29,19
12	x 12	x 200	35473	37,93
14	x 14	x 200	35474	45,03
16	x 16	x 200	35475	56,07
18	x 18	x 200	35476	81,45
20	x 20	x 200	35477	104,99
25	x 25	x 200	35478	164,50

Ref. **8991**

CUCHILLA REDONDA TORNEADO

Round Turning Blade
Outil de tour rond

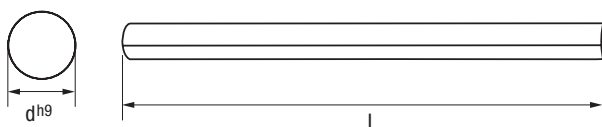

Cuchillas Torno
Turning Tools
Outils de tour

HSSE
10%Co

DIN
4964A



d mm	L mm	Nº Art.	€
4	x 100	35479	6,05
5	x 100	35480	6,94
5	x 200	35481	13,92
6	x 100	35482	7,85
6	x 160	35484	11,79
6	x 200	35483	14,34
8	x 100	35485	10,26
8	x 160	35486	16,16
8	x 200	35487	19,21
10	x 100	35488	15,20
10	x 160	35489	26,98
10	x 200	35490	33,36
12	x 100	35491	16,62
12	x 200	35492	43,14
14	x 200	35493	60,15
16	x 200	35494	63,32
18	x 200	35495	109,91
20	x 200	35497	110,71

Ref. **8992**

CUCHILLA TRAPEZOIDAL TORNEADO

Trapezoidal Turning Blade
Outil de tour trapézoïdal



HSSE
10%Co

DIN
4964E

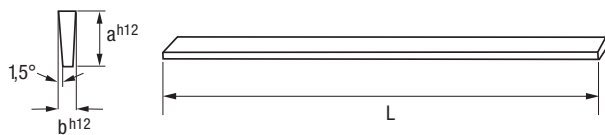

a mm	b mm	L mm	Nº Art.	€
10	2,50	100	13690	11,89
12	3,00	100	13691	13,14
12	3,00	160	13693	18,80
16	4,00	100	13782	19,07
16	4,00	160	13786	38,71
20	5,00	160	13787	47,80
20	5,00	200	14213	66,03
25	6,00	160	14225	64,42

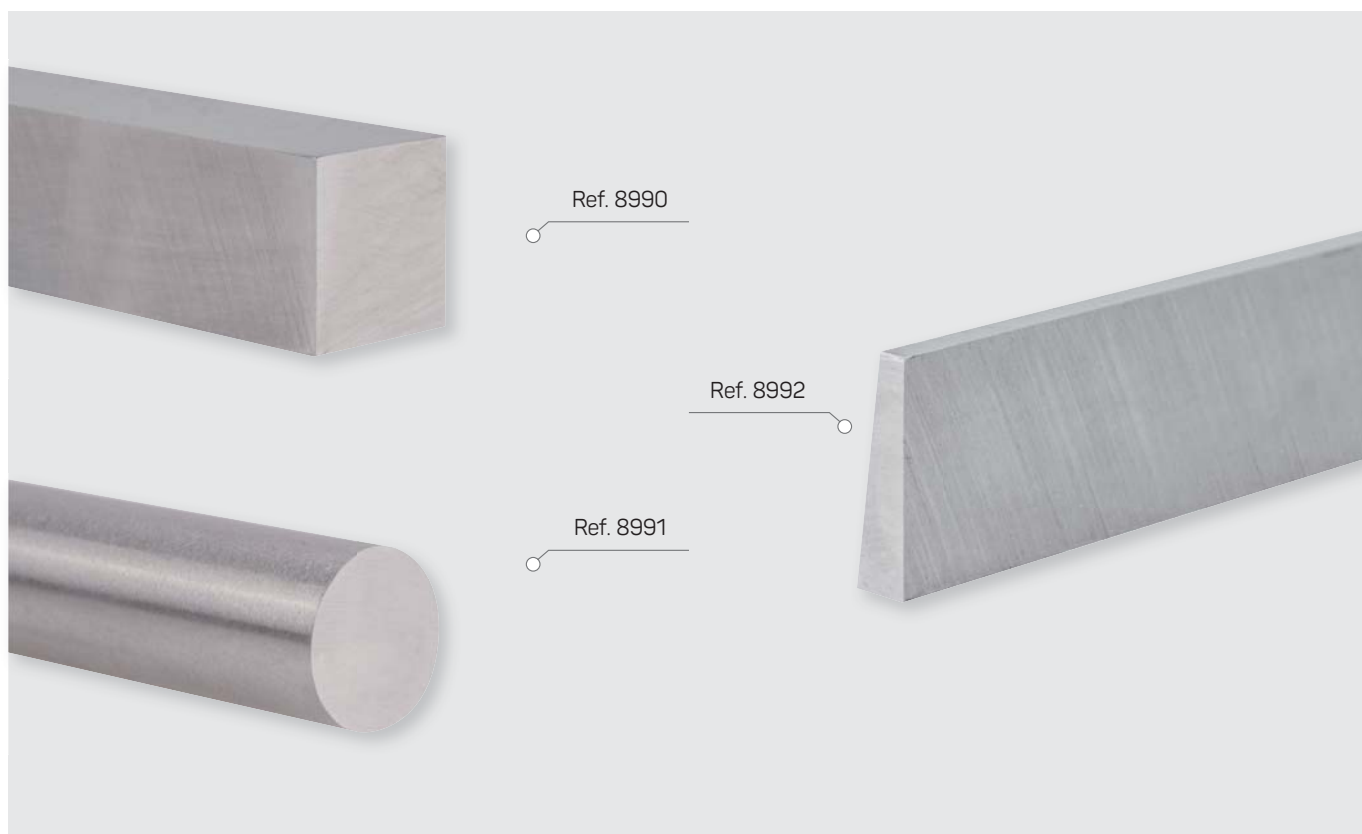

Ref. 8990

Ref. 8992

Ref. 8991

Ref. **8301**

GRANETE
Centre Punch
Pointeau à marquer



D mm	d mm	L mm		Nº Art.	€ 1 ud.
2	9	130	10	13302	3,71
4	9	130	10	13304	3,71
5	11	150	10	13305	6,70
6	11	160	10	13306	6,70
8	11	160	10	13307	6,70



Ref. **8302**

BOTADOR CÓNICO
Taper Punch
Poinçon conique



D mm	d mm	L mm		Nº Art.	€ 1 ud.
2	9	130	10	13308	4,92
4	9	130	10	13309	4,92
5	9	130	10	13310	4,92
6	11	160	10	13311	6,17
8	11	160	10	13312	6,21
10	11	160	10	13313	6,37



Ref. **8303**

BOTADOR CILÍNDRICO
Parallel Punch
Poinçon cylindrique



D mm	d mm	L mm		Nº Art.	€ 1 ud.
2	9	160	10	13314	3,60
3	9	160	10	13315	3,65
4	9	160	10	13317	3,68
5	11	160	10	13316	4,50
6	11	160	10	13318	4,52
7	11	160	10	13324	4,52
8	11	160	10	13915	4,57
9	11	160	10	13916	4,59
10	11	160	10	13917	4,59



Ref. **8304**

CINCEL Y BURIL
Cold & Cape Chisel
Ciseau et burin



Tipo Type Type	D mm	d mm	L mm		Nº Art.	€ 1 ud.
Cinzel Cold Chisel Ciseau	12	9,5	13	10	13918	7,01
Buril Cape Chisel Burin	5	9,5	13	10	13920	8,32



Ref. **8310**

SETS GRANETES, BOTADORES, CINCELES Y BURILES

Punches and Chisels Sets

Sets pointeaux, poinçons, ciseaux et burins



Mod. **1**

6 Pcs



Mod. **2**

6 Pcs



Mod. **3**

6 Pcs



Mod. **4**

6 Pcs



Mod. **5**

6 Pcs



Mod. **6**

6 Pcs

Cont. Ref.	Cont. Descrip.	Nº Art.	€
8304 8302 8301	Buril, Cincel, Cónicos 2-4, Granetes 4-6 Cold & Cape Chisel, Taper 2-4 & Centre Punch. 4-6 Burin, Ciseau, Coniques 2-4, Pointeaux 4-6	13921	40,38
8304 8302 8301 8303	Buril, Cincel, Cónico 4, Granete 4, Cilíndricos 4-8 Cold & Cape Chisel, Taper 4, Centre 4 & Parallel 4-8 Burin, Ciseau, Conique 4, Pointeau 4, Cylindriques 4-8	13923	40,18
8304 8301	Buril, Cincel, Granetes 2-4-6-8 Cold & Cape Chisel, Centre Punches 2-4-6-8 Burin, Ciseau, Pointeaux 2-4-6-8	13924	42,49
8302	Cónicos 2-4-5-6-8-10 Taper Punches 2-4-5-6-8-10 Coniques 2-4-5-6-8-10	13926	37,24
8303	Cilíndricos 2-3-4-5-6-7 Parallel Punches 2-3-4-5-6-7 Cylindriques 2-3-4-5-6-7	13927	29,15
8303	Cilíndricos 5-6-7-8-9-10 Parallel Punches 5-6-7-8-9-10 Cylindriques 5-6-7-8-9-10	13928	40,44

Ref. **8350**

JUEGO REBARBADORES

Deburring Tool Sets
Jeux ébavureurs



MOD. B



Juego
Mod. B
Set



Aceros
<850 N/mm²
Steel / Aciers

Fundición
Cast Iron
Fonte

Cobre
Copper
Cuivre

Latón
Brass
Laiton

Aluminio
Aluminium

Plásticos
Plastics
Plastiques



B10



B20

4 Pcs

Cont.

Nº Art.

€

Mango / Shank / Queue

Porta **Universal** Holder

B10 / B20

12816

21,65

MOD. E



Juego
Mod. E
Set



Aceros
<850 N/mm²
Steel / Aciers

Fundición
Cast Iron
Fonte

Cobre
Copper
Cuivre

Latón
Brass
Laiton

Aluminio
Aluminium

Plásticos
Plastics
Plastiques



E100



E200



E300

5 Pcs

Cont.

Nº Art.

€

Mango / Shank / Queue

Porta **Universal** Holder

E100 / E200 / E300

12805

24,44



Ref. **8351**

ACCESORIOS REBARBADORES

Deburring Tool Accessories
Accessoires ébavureurs



Mango / Shank / Queue

Medida Size - Dimension	Icon	Nº Art.	€
00001		1 12834	10,48



Porta **Universal** Holder

Medida Size - Dimension	Icon	Nº Art.	€
00006UNI		1 76576	8,51



Cuchillas Blades Lames	Material Materiel	Icon	Nº Art.	€ pack
B10	HSS		10 12825	15,05
B20	HSS		10 12827	15,05



Cuchillas Blades Lames	Material Materiel	Icon	Nº Art.	€ pack
E100	HSS		10 12829	17,86
E100S	HSSE		10 12830	19,52
E200	HSS		10 12831	17,86
E300	HSS		10 12833	20,57

Aplicación Application Application	Material Material Materiel	Aceros <850 N/mm² Steel / Aciers		Latón Brass Laiton		INOX Stainless Steel Acier INOX		Plásticos Plastics Plastiques	
		Cobre Copper Cuivre	Aluminio Aluminium	Fundición Cast Iron Fonte					
Bordes rectos Straight Edges Bouts droits		B10 E100		B20 E200		E100S		B10 E100 E100S B20 E200	
Bordes de Agujeros Hole Edges Bouts de trous		E100S							
Bordes Agujeros Pasantes Through Hole Edges Bouts de trous débouchants		E300						E300	

Ref. **8325**

CORTA TUBOS 25 mm

25 mm Pipe Cutters
Coupe tubes 25 mm

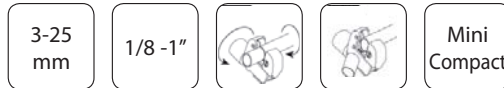

INOX Stainless Steel Acier INOX	Cobre Copper Cuivre	Aluminio Aluminium
--	----------------------------------	------------------------------

Mod.	Min. mm	Max. mm	Pulgadas Inches Pouces	Nº Art.	€
25	3	25	1/8 - 1"	34244	12,92



Ref. **8330**

CORTA TUBOS 30 mm

30 mm Pipe Cutters
Coupe tubes 30 mm



INOX Stainless Steel Acier INOX	Cobre Copper Cuivre	Aluminio Aluminium
--	----------------------------------	------------------------------

Mod.	Min. mm	Max. mm	Pulgadas Inches Pouces	Nº Art.	€
30	3	30	1/8 - 1 1/8"	34245	13,39



Ref. **8335**

CORTA TUBOS 35 mm

35 mm Pipe Cutters
Coupe tubes 35 mm



Cambio Rápido Cuchilla
Quick Cutting Wheel Change
Changement rapide molette

Rebarbador incluido
Deburring Tool included
Ébavureur compris

INOX Stainless Steel Acier INOX	Cobre Copper Cuivre	Aluminio Aluminium
--	----------------------------------	------------------------------

Mod.	Min. mm	Max. mm	Pulgadas Inches Pouces	Nº Art.	€
35	3	35	1/8 - 1 3/8"	34246	32,84



Ref. **8341**

CUCHILLAS REPUESTO

Spare Wheels
Lames de rechange

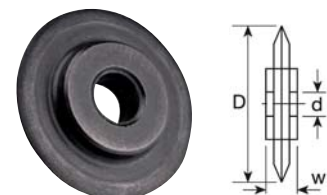

Mod.	D mm	d mm	w mm	Nº Art.	€
1	20	5	5	34247	2,55

Ref. **8326**

CORTA TUBOS TIJERA PLÁSTICO Y MULTICAPA

Plastic & Multilayer Pipe Scissors

Coupe tubes ciseaux pour plastique et multicouche



26 mm
(1")

INOX+Teflon®
Stainless+Teflon®
INOX+Téflon®

Cuerpo Mg
Mg Body
Corps Mg

PE, PP, PB, PEX, MLP/MSR, VPE, CPVC,
PVC, PVDF, PPR

- 1- Cuchilla INOX + Teflon®: Menor adherencia entre tubo y cuchilla
- 2- Zona de apoyo mejorada: Tubo mejor asentado, corte más preciso
- 3- Cambio cuchilla instantaneo: Sin necesidad de herramientas

- 1- Stainless + Teflon® blade: Lower adhesion between pipe & blade
- 2- Improved base area: Better leaned pipe, accurate cutting
- 3- Instant blade change: No tools needed

- 1- Lame INOX + Téflon®: Moindre adhérence entre tuyau et lame
- 2- Zone d'appui améliorée: Tuyau mieux fixé, coupe plus précis
- 3- Changement de lame immédiat: Sans besoin d'outils



Mod.	Max. mm	Pulgadas Inches Pouces	Nº Art.	€
26	26	1"	36633	28,68

Ref. **8321**

INOX+Teflon®
Stainless+Teflon®
INOX+Téflon®



Hoja Blade Lame mm		Nº Art.	€
26	1	37423	10,82

Ref. **8342**

CORTA TUBOS TIJERA PLÁSTICO Y MULTICAPA

Plastic & Multilayer Pipe Scissors

Coupe tubes ciseaux pour plastique et multicouche



42 mm
(1 5/8")

INOX+Teflon®
Stainless+Teflon®
INOX+Téflon®

Cuerpo Mg
Mg Body
Corps Mg

PE, PP, PB, PEX, MLP/MSR, VPE, CPVC,
PVC, PVDF, PPR

- 1- Cuchilla INOX + Teflon®: Menor adherencia entre tubo y cuchilla
- 2- Zona de apoyo mejorada: Tubo mejor asentado, corte más preciso
- 3- Cambio cuchilla instantaneo: Sin necesidad de herramientas
- 4- Cuchilla recogida en el cuerpo

- 1- Stainless + Teflon® blade: Lower adhesion between pipe & blade
- 2- Improved base area: Better leaned pipe, accurate cutting
- 3- Instant blade change: No tools needed
- 4- Blade positioned within the body

- 1- Lame INOX + Téflon®: Moindre adhérence entre tuyau et lame
- 2- Zone d'appui améliorée: Tuyau mieux fixé, coupe plus précis
- 3- Changement de lame immédiat: Sans besoin d'outils
- 4- Lame dans le corps de l'outil



Mod.	Max. mm	Pulgadas Inches Pouces	Nº Art.	€
42	42	1"5/8	36635	49,79

Ref. **8321**

INOX+Teflon®
Stainless+Teflon®
INOX+Téflon®



Hoja Blade Lame mm		Nº Art.	€
42	1	37424	20,06

Ref. **8345****RECOGEVIRUTAS MAGNÉTICO**Magnetic Retrieving Baton
Aimant à copeaux

D mm	L mm	Nº Art.	€
25,40	400	69499	52,70

Imán especialmente diseñado para recoger viruta ferrosa en lugares difícilmente accesibles. Ideal para cubos de almacenaje, limpieza de agua o desengrasado de tanques, muros y esquinas... Práctico extensor que deja caer el material recogido a la vez que protege la mano de la viruta.

Specially designed Magnet to retrieve ferrous metal materials from hard to reach locations. Ideal for storage bins, water cleaning or tank degreasing, walls and corners... Practical extension for an easy releasing the collected material. It protects the hand from the chips.

Aimant spécialement dessiné pour ramasser les copeaux de fer dans des zones de difficile accès. Conseillés pour nettoyage d'eau, murs, corners. Pratique extenseur qui permet que le materiel tombe une fois ramassé et protège les mains des copeaux.

CONSTRUCCIÓN

Construction
Construction

HERRAMIENTAS SDS PLUS

SDS plus Tools
Outils SDS plus

210

BROCAS MANGO CILÍNDRICO

Straight Shank Drill Bits
Forets queue cylindrique

230

HERRAMIENTAS SDS MAX

SDS max Tools
Outils SDS max

220

CORONAS

Hole Saws
Tréfans

247

ADAPTADOR iCONNECT

iConnect Adaptor
Adaptateur iConnect

224

DISCOS DIAMANTE

Diamond Cutting Blades
Disques diamant

257

CINCELES

Chisels
Burins

226

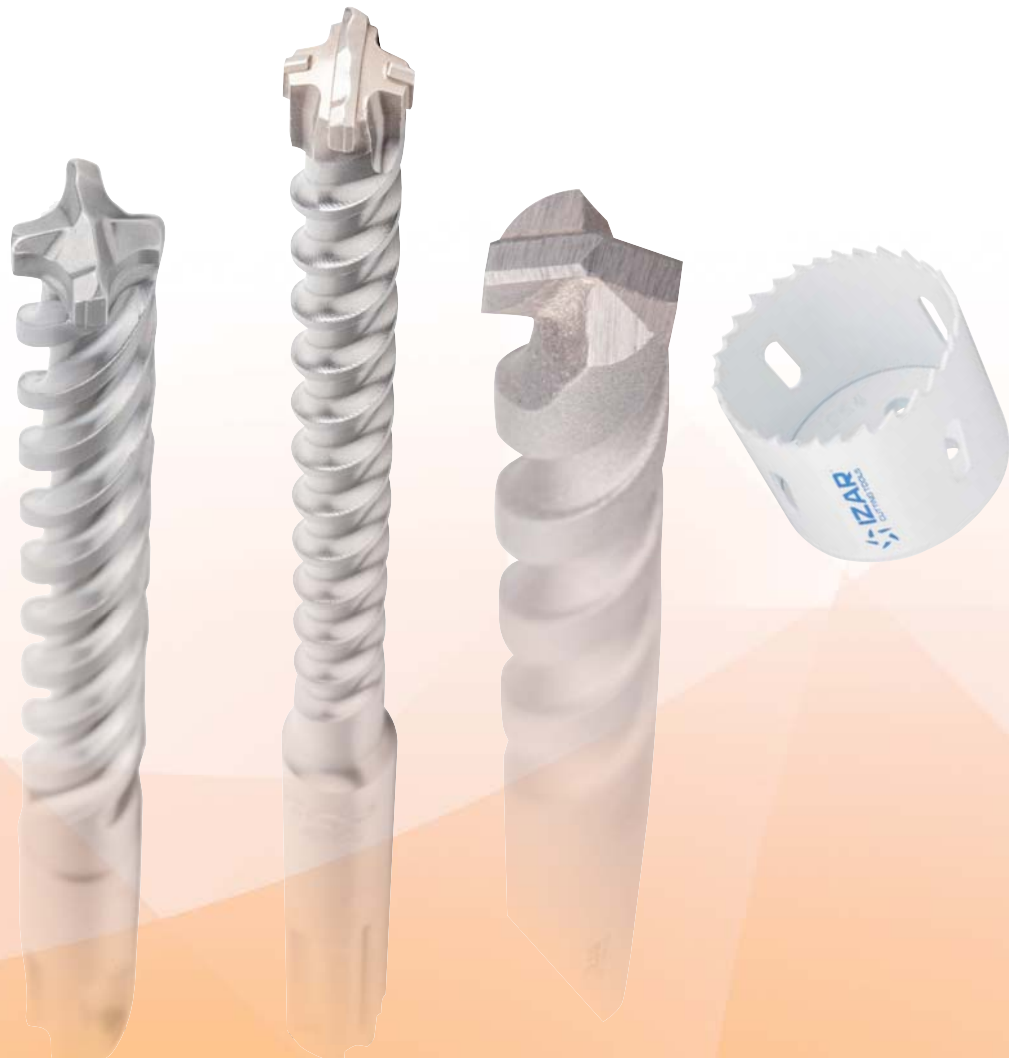

HERRAMIENTAS SDS PLUS

SDS plus Tools

Outils SDS plus

Ref. **1891**

BROCA-MARTILLO SDS PLUS 4Z+

4Z+ Cutter SDS plus Rotary Hammer Drill Bit

Foret percussion SDS plus 4Z+

Zentro 4+



Zentro
4+
<10mm

Zentro
4
10-16 mm

SDS
plus



Video



Hormigón Reforzado
Reinforced Concrete
Béton armé

Hormigón
Concrete
Béton

Hormigón Bloque
Concrete Block
Parpaing

Piedra Natural
Natural Stone
Pierre naturelle



Punta centradora MD soldada al cuerpo

Solid carbide centering tip welded to the body

Pointe autocentrante carbure soudée au corps



Hombros reforzados

=> Mejor rotura del material.
Marca desgaste

Reinforced shoulders

=> Better material breaking.
Wear Marking

Épaules de la pointe reforçadas

=> Meilleure rupture du matériel.
Marque l'usure.

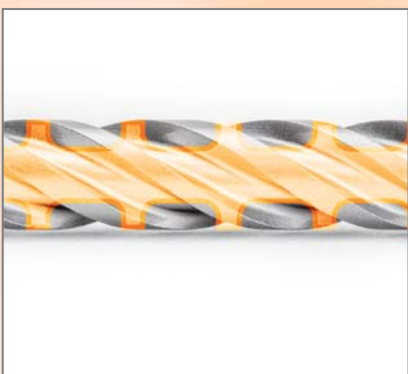

Diseño nucleo reforzado exclusivo

=> Mejor rendimiento y vida más larga

Exclusive reinforced core design

=> Better performance & longer life

Dessin noyau renforcée et exclusive

=> Meilleure performance et vie de l'outil plus longue

Ref. **1891**

BROCA-MARTILLO SDS PLUS 4Z+

4Z+ Cutter SDS plus Rotary Hammer Drill Bit
Foret percussion SDS plus 4Z+

D mm	L mm	I mm		Nº Art.	€
5,00	115	50	1	32043	4,80
5,00	165	100	1	32044	5,37
5,00	215	150	1	55961	7,87
5,00	265	200	1	66376	9,81
5,00	315	250	1	69437	12,59
5,50	115	50	1	32041	6,38
5,50	165	100	1	32042	6,67
6,00	115	50	1	32045	4,70
6,00	165	100	1	32046	5,15
6,00	215	150	1	32047	6,93
6,00	265	200	1	32048	8,32
6,00	315	250	1	32049	12,19
6,50	165	100	1	32050	6,68
6,50	215	150	1	32074	9,05
6,50	265	200	1	32072	12,06
6,50	315	250	1	32073	14,67
7,00	115	50	1	32052	6,34
7,00	165	100	1	32053	6,72
7,00	215	150	1	68615	9,26
8,00	115	50	1	32054	6,17
8,00	165	100	1	32055	6,17
8,00	215	150	1	32056	7,74
8,00	265	200	1	32057	8,49
8,00	315	250	1	36686	10,84
8,00	465	400	1	36687	17,93
9,00	165	100	1	56808	8,26
10,00	115	50	1	32058	7,01

D mm	L mm	I mm		Nº Art.	€
10,00	165	100	1	32059	7,49
10,00	215	150	1	32060	8,94
10,00	265	200	1	32061	11,51
10,00	315	250	1	32062	14,64
10,00	455	400	1	32063	20,08
10,00	600	550	1	36688	25,59
10,00	1000	950	1	36689	60,04
11,00	160	110	1	69899	9,78
11,00	210	160	1	69902	11,78
11,00	260	210	1	69904	13,87
11,00	310	260	1	81562	18,46
12,00	160	110	1	32064	9,30
12,00	210	160	1	32065	11,10
12,00	260	210	1	32066	13,45
12,00	310	260	1	32067	17,48
12,00	450	400	1	32068	21,85
12,00	600	550	1	36690	26,28
12,00	1000	950	1	36697	60,35
13,00	160	110	1	69905	10,84
13,00	210	160	1	69907	18,11
13,00	260	210	1	69908	20,54
13,00	310	260	1	81563	22,00
14,00	160	110	1	32069	10,75
14,00	210	160	1	32070	14,43
14,00	260	210	1	32071	16,14
14,00	310	260	1	36691	20,69
14,00	450	400	1	36692	25,92

D mm	L mm	I mm		Nº Art.	€
14,00	600	550	1	36693	36,19
14,00	1000	950	1	36694	80,96
15,00	160	110	1	60059	16,62
15,00	260	210	1	60061	21,58
15,00	450	400	1	60062	28,01
16,00	160	110	1	36695	20,57
16,00	210	160	1	36696	23,13
16,00	260	210	1	36863	26,75
16,00	310	260	1	36699	27,95
16,00	450	400	1	37455	35,03
16,00	600	550	1	22113	47,26
16,00	1000	950	1	36698	95,97
18,00	250	200	1	16919	35,83
18,00	450	400	1	16920	42,10
20,00	250	200	1	16921	40,46
20,00	450	400	1	16922	48,25
22,00	250	200	1	39687	48,82
22,00	450	400	1	16925	58,11
24,00	250	200	1	39688	54,80
24,00	450	400	1	16927	61,51
25,00	250	200	1	39689	56,29
25,00	450	400	1	16928	62,37
28,00	250	200	1	11523	65,05
28,00	450	400	1	11524	71,69
30,00	250	200	1	39690	83,19
30,00	450	400	1	11525	90,78
32,00	450	400	1	11526	101,36



Línea 1m
1891

BROCA-MARTILLO SDS PLUS 4Z+

4Z+ Cutter SDS plus Rotary Hammer Drill Bit
Foret percussion SDS plus 4Z+



Ø	5	6	7	8	10	5	6	7	8	10	12	14	6	8	10	12	14	8	16
	L115	L115	L115	L115	L115	L165	L165	L165	L165	L165	L160	L160	L215	L215	L215	L210	L210	L265	L260
Pcs	2	2	2	2	2	2	2	2	2	2	2	2	2	2	2	2	2	2	2

Ref. 4995 - Nº Art. 71015: **328,71 €**



Display 67



BROCA-MARTILLO SDS PLUS 4Z+ (1)

4Z+ Cutter SDS plus Rotary Hammer Drill Bit (1)

Foret percussion SDS plus 4Z+ (1)

∅	24 L250	6 L315	8 L315	10 L315	12 L310	14 L310	16 L310	8 L465
Pcs	1	2	2	1	1	1	1	1
∅	5 L215	6 L215	8 L215	10 L215	12 L210	14 L210	16 L210	6 L265
Pcs	3	3	3	2	2	2	2	2
∅	5 L115	6 L115	7 L115	8 L115	10 L115	5 L165	6 L165	6 L165
Pcs	4	4	4	4	3	4	3	3

Ref. 4995 - Nº Art. 75389: 560,45 €

Display 68



BROCA-MARTILLO SDS PLUS 4Z+ (2)

4Z+ Cutter SDS plus Rotary Hammer Drill Bit (2)

Foret percussion SDS plus 4Z+ (2)

∅	10 L455	12 L450	14 L450	16 L450	18 L450	20 L450	22 L450	24 L450
Pcs	1	1	1	1	1	1	1	1
∅	8 L265	10 L265	12 L260	14 L260	16 L260	18 L250	20 L250	22 L250
Pcs	2	2	1	1	1	1	1	1
∅	7 L165	8 L165	9 L165	10 L165	12 L160	14 L160	15 L160	16 L160
Pcs	2	2	2	2	1	1	1	1

Ref. 4995 - Nº Art. 75391: 648,82 €

Display 61



BROCA-MARTILLO SDS PLUS 4Z+ (BÁSICO)

4Z+ Cutter SDS plus Rotary Hammer Drill Bit (Basic)

Foret percussion SDS plus 4Z+ (Essentiel)

∅	14 L210	6 L265	8 L265	10 L265	12 L260	6 L315	10 L315	12 L310
Pcs	2	2	2	2	2	2	2	2
∅	8 L165	10 L165	12 L160	14 L160	6 L215	8 L215	10 L215	12 L210
Pcs	2	2	2	2	2	2	2	2
∅	5 L115	6 L115	7 L115	8 L115	10 L115	5 L165	6 L165	7 L165
Pcs	2	2	2	2	2	2	2	2

Ref. 4995 - Nº Art. 29487: 430,39 €

Display 31

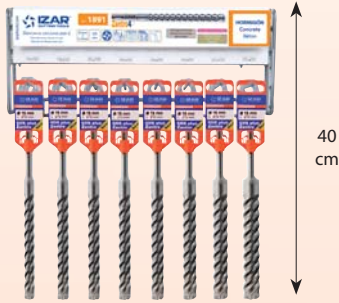

40 cm

Display 32



60 cm

ø	16	18	20	22	24	25	28	30
	L260	L250	L250	L250	L250	L250	L250	L250
Pcs	1	1	1	1	1	1	1	1

Ref. 4995 - N° Art. 22615: 411,19 €

ø	16	18	20	22	24	25	28	30
	L450	L450	L450	L450	L450	L450	L450	L450
Pcs	1	1	1	1	1	1	1	1

Ref. 4995 - N° Art. 22617: 469,83 €



Ref. 1869

BROCA-MARTILLO SDS PLUS 4Z+

4Z+ Cutter SDS plus Rotary Hammer Drill Bit
Foret percussion SDS plus 4Z+

D mm	L mm	I mm		N° Art.	€ 1 ud.
5	115	50	10	56503	4,55
5	165	100	10	56506	5,10
6	115	50	10	56507	4,47
6	165	100	10	56509	4,89
6	215	150	10	56510	6,59
8	115	50	10	56967	5,86
8	165	100	10	56971	5,86

D mm	L mm	I mm		N° Art.	€ 1 ud.
8	215	150	10	56972	7,35
10	115	50	10	56973	6,67
10	165	100	10	56974	7,12
10	215	150	10	56976	8,49
12	160	110	10	56978	8,83
12	210	160	10	56979	10,54



Ref. 1489

7 Pcs

Cont. Ø	N° Art.	€
5-6-8 x 115 + 6-8-10-12 x 165 mm	39851	39,41

Ref. **1890**

BROCA-MARTILLO SDS PLUS

SDS plus Rotary Hammer Drill Bit
Foret percussion SDS plus



Hormigón
Concrete
Béton

Hormigón Bloque
Concrete Block
Parpaing



Puntos de desbaste efecto "demolición".
Producen micro-fisuras en el material.

"Demolition" effect power breakers.
Produce micro cracks in the material.

Points d'ébauche effet "démolition".
Produit des micro-fissures dans le matériel.



Punta centrado inmediato.
Previene que resbale en superficies lisas.

Immediate centering tip.
Prevent skidding on smooth surfaces.

Pointe Autocentrage immédiat.
Il prévient le glissement sur Surfaces lisses.



Chañflanes de acero corrugado más extenso (+35%).
Previenen daños laterales en la punta.

Enlarged rebar chamfers (+35%).
Prevent side tip damage.

Chanfreins aciers contractés plus étendus (+35%).
Il prévient des dommages aux côtés de la pointe.

D mm	L mm	I mm		Nº Art.	€
4,0	110	50	1	30245	3,96
4,0	160	100	1	43405	4,82
5,0	110	50	1	30246	2,87
5,0	160	100	1	30247	3,74
5,0	210	150	1	42770	5,96
5,0	260	200	1	70631	7,24
5,0	310	250	1	69445	7,99
5,0	360	300	1	70633	12,57
5,0	460	400	1	70634	21,75
5,5	110	50	1	23976	3,33
5,5	160	100	1	23977	4,19
5,5	210	150	1	70636	6,87
5,5	260	200	1	69446	8,91
5,5	310	250	1	70637	10,46
6,0	110	50	1	30248	2,94
6,0	160	100	1	18538	3,40
6,0	210	150	1	30249	5,62
6,0	260	200	1	30251	7,23
6,0	310	250	1	70639	11,29
6,0	460	400	1	69448	15,11
6,5	110	50	1	23978	3,38
6,5	160	100	1	23979	3,96
6,5	260	200	1	59957	8,58
7,0	110	50	1	30252	4,26
7,0	160	100	1	30253	4,57
7,0	210	150	1	68614	5,79
7,0	250	200	1	19592	8,22
8,0	110	50	1	30254	3,56
8,0	160	100	1	18540	3,73
8,0	210	150	1	30255	5,08
8,0	260	200	1	30256	7,21
8,0	460	400	1	30257	15,11
8,0	1000	950	1	70030	52,31

D mm	L mm	I mm		Nº Art.	€
9,0	160	100	1	11518	5,67
9,0	210	150	1	11519	6,18
10,0	110	50	1	30261	4,25
10,0	160	100	1	30262	4,76
10,0	210	150	1	18541	5,73
10,0	260	200	1	30263	8,42
10,0	310	250	1	30264	9,77
10,0	450	400	1	30266	15,81
10,0	600	550	1	30267	22,14
10,0	800	740	1	70640	34,28
10,0	1000	950	1	69911	52,91
11,0	160	100	1	11520	6,25
11,0	210	150	1	25600	6,33
11,0	260	200	1	11521	9,69
12,0	160	100	1	30270	5,06
12,0	210	150	1	30271	6,41
12,0	260	200	1	30273	9,11
12,0	310	250	1	42771	12,28
12,0	450	400	1	30414	14,47
12,0	600	550	1	30275	22,92
12,0	800	750	1	69916	37,20
12,0	1000	950	1	30269	54,76
13,0	160	100	1	30276	6,04
13,0	210	150	1	74789	9,44
13,0	310	250	1	30278	11,87
13,0	450	400	1	55407	19,56
14,0	160	100	1	30280	6,96
14,0	210	150	1	30281	10,16
14,0	260	200	1	42772	12,19
14,0	310	250	1	30283	12,86
14,0	450	400	1	30284	16,91
14,0	600	550	1	30285	25,10
14,0	1000	950	1	30279	59,53

D mm	L mm	I mm		Nº Art.	€
15,0	160	100	1	30286	9,67
15,0	210	150	1	69917	11,79
15,0	260	200	1	42773	12,61
15,0	450	400	1	70642	21,11
16,0	160	100	1	30291	9,67
16,0	210	150	1	30292	11,79
16,0	260	200	1	42774	12,72
16,0	310	250	1	30294	13,60
16,0	450	400	1	30295	20,10
16,0	600	550	1	30296	27,01
16,0	800	750	1	30298	44,22
16,0	1000	950	1	30290	67,59
18,0	200	150	1	30300	15,14
18,0	300	250	1	30413	20,13
18,0	450	400	1	30303	22,95
18,0	1000	950	1	30299	69,50
20,0	200	150	1	30306	21,05
20,0	300	250	1	30309	23,62
20,0	450	400	1	30311	29,80
20,0	600	550	1	30312	44,22
20,0	1000	950	1	30305	70,49
22,0	250	200	1	30314	27,04
22,0	450	400	1	30317	37,65
22,0	600	550	1	23980	45,08
22,0	1000	950	1	23986	71,15
24,0	250	200	1	30319	31,55
24,0	450	400	1	30322	40,94
25,0	250	200	1	30324	34,16
25,0	450	400	1	30327	43,78
25,0	1000	950	1	23987	78,59
26,0	250	200	1	11522	42,79
26,0	450	400	1	30330	48,32

Línea 1m
1890

BROCA-MARTILLO SDS PLUS

SDS plus Rotary Hammer Drill Bit
Foret percussion SDS plus



∅	5	6	7	8	10	5	6	7	8	10	12	14	6	8	10	12	14	8	16
	L110	L110	L110	L110	L110	L160	L160	L160	L160	L160	L160	L160	L210	L210	L210	L210	L210	L260	L260
Pcs	5	5	3	5	3	5	5	3	3	3	3	3	3	3	3	3	3	2	2

Ref. 4995 - Nº Art. 71017: 322,27 €



Doble Blister ref. M890 pag. 374

Display
01

BROCA-MARTILLO SDS PLUS 1

SDS plus Rotary Hammer Drill Bit 1
Foret percussion SDS plus 1



∅	18	20	22	24	25	8	10	12		
	L300	L300	L250	L250	L250	L460	L450	L450		
Pcs	1	1	1	1	1	2	2	2		
∅	6	8	10	12	14	16	18	20		
	L210	L210	L210	L210	L210	L210	L200	L200		
Pcs	3	3	3	3	3	1	1	1		
∅	4	5	6	7	8	10	5	6	7	8
	L110	L110	L110	L110	L110	L110	L160	L160	L160	L160
Pcs	5	5	5	3	5	3	5	5	3	3

Ref. 4995 - Nº Art. 22182: 527,09 €

Display
02

BROCA-MARTILLO SDS PLUS 2

SDS plus Rotary Hammer Drill Bit 2
Foret percussion SDS plus 2



∅	14	16	18	20	22	24	25	26
	L450	L450	L450	L450	L450	L450	L450	L450
Pcs	3	1	1	1	1	1	1	1
∅	6	8	10	12	10	13	14	16
	L260	L260	L260	L260	L310	L310	L310	L310
Pcs	3	3	3	3	3	2	2	2
∅	9	10	11	12	13	14	15	16
	L160	L160	L160	L160	L160	L160	L160	L160
Pcs	2	2	2	3	3	3	2	2

Ref. 4995 - Nº Art. 22183: 622,38 €

Display 45

BROCA-MARTILLO SDS PLUS BÁSICO

Basic SDS plus Rotary Hammer Drill Bit
Foret percussion SDS plus Essentiel



∅	12 L260	14 L310	16 L310	8 L460	10 L450	12 L450	14 L450	16 L450		
Pcs	3	2	2	1	1	2	1	1		
∅	14 L160	16 L160	6 L210	8 L210	10 L210	12 L210	14 L210	10 L260		
Pcs	3	2	5	3	3	3	3	3		
∅	4 L110	5 L110	6 L110	8 L110	10 L110	5 L160	6 L160	8 L160	10 L160	12 L160
Pcs	5	5	5	5	5	5	5	5	4	3

Ref. 4995 - N° Art. 55614: 529,38 €

Display 25



31
cm

∅	4 L110	5 L110	6 L110	7 L110	8 L110	10 L110	5 L160	6 L160	7 L160	8 L160
Pcs	5	5	5	3	5	3	5	5	3	3

Ref. 4995 - N° Art. 22278: 152,80 €

Display 26



31
cm

∅	9 L160	10 L160	11 L160	12 L160	13 L160	14 L160	15 L160	16 L160
Pcs	2	2	2	3	3	3	2	2

Ref. 4995 - N° Art. 22604: 126,25 €

Display 27



∅	6	8	10	12	14	16	18	20
	L210	L210	L210	L210	L210	L210	L200	L200
Pcs	3	3	3	3	3	1	1	1

Ref. 4995 - N° Art. 22605: 147,01 €

Display 28



∅	6	8	10	12	10	13	14	16
	L260	L260	L260	L260	L310	L310	L310	L310
Pcs	3	3	3	3	3	2	2	2

Ref. 4995 - N° Art. 22609: 201,87 €

Display 29



∅	18	20	22	24	25	8	10	12
	L300	L300	L250	L250	L250	L460	L450	L450
Pcs	1	1	1	1	1	2	2	2

Ref. 4995 - N° Art. 22612: 227,27 €

Display 30



∅	14	16	18	20	22	24	25	26
	L450	L450	L450	L450	L450	L450	L450	L450
Pcs	3	1	1	1	1	1	1	1

Ref. 4995 - N° Art. 22614: 294,26 €

Ref. **1899**

BROCA-MARTILLO SDS PLUS

SDS plus Rotary Hammer Drill Bit
Foret percussion SDS plus



D mm	L mm	I mm		Nº Art.	€ 1 ud.
5	110	50	10	18706	2,73
5	160	100	10	18707	3,55
6	110	50	10	18710	2,80
6	160	100	10	18712	3,23
6	210	150	10	18714	5,34
7	160	100	10	74777	3,77
8	110	50	10	18715	3,38
8	160	100	10	18716	3,54
8	210	150	10	18717	4,83

D mm	L mm	I mm		Nº Art.	€ 1 ud.
10	110	50	10	18719	4,03
10	160	100	10	18721	4,53
10	210	150	10	18722	5,45
12	160	100	10	18723	4,81
12	210	150	10	18724	6,09
13	160	100	10	74778	5,74
13	210	150	10	74780	8,97
14	160	100	10	74782	6,61
14	210	150	10	74783	9,65



Ref. **1494**

4 Pcs

Cont. Ø	Nº Art.	€
5x110 6x110 8x160 10x160 mm	11528	17,91



Ref. **1497**

7 Pcs

Cont. Ø	Nº Art.	€
5-6-8 x 110 + 6-8-10-12 x 160 mm	11529	26,33

Línea 33 cm
14S2

SETS BROCAS HORMIGÓN, PARED PRO, PARED

Concrete, Masonry Sets
Jeux béton, maçonnerie



	Hormigón Concrete Béton	Pared Pro Concrete Béton	Pared Masonry Maçonnerie
Ref.	1494	1487	1488
Diam	5/6x110 + 8/10x160 mm	3-4-5-6-7-8-9-10 mm	3-4-5-6-7-8-9-10 mm
Pcs.	3	5	5

Ref. 4995 - Nº Art. 72194: 217,44 €

Ref. **1695**

CORONA LIGERA PARED PROFESIONAL

Professional Concrete Light Hollow Core Bit
Trépan béton professionnel



Diente MD
Carbide Tipped
Dent Carbure



SDS plus

Rosca Interna M-16
M-16 Internal Thread
Filetage Intérieur M-16



Hormigón
Concrete
Béton

Hormigón Bloque
Concrete Block
Parpaing

Ladrillo
Brick
Brique



- Más robusta
- Nueva geometría de canales mejorada

- Now Stronger
- New improved channel geometry

- Plus robuste
- Nouvelle géométrie améliorée des goujures

D mm	L mm	Nº Art.	€
30	50	13898	42,77
35	50	13899	50,64
40	50	13900	58,06
45	50	13901	61,13

D mm	L mm	Nº Art.	€
50	50	13902	63,74
65	50	13904	66,68
68	50	19012	70,03
80	50	19014	70,03

D mm	L mm	Nº Art.	€
82	50	19032	87,24
90	50	25207	89,27
100	50	25208	103,08



Ref. **1696**

Broca Centrar
Center Drill / Foret à Centrer



00001

Broca Drill Bit Mod.	D mm	L mm	Nº Art.	€
1	8	120	18857	8,30

Husillo SDS plus
SDS plus Spindle / Arbre SDS plus



00003-5

SDS plus Mod.	L mm	Nº Art.	€
3	105	18858	23,58
4	220	19021	31,37
5	370	19023	44,57

Husillo Hex
Hex Spindle / Arbre Hex



00006-8

HEX Mod.	L mm	Nº Art.	€
6	100	19018	20,77
7	220	19026	27,22
8	370	19030	36,45

Display
05

CORONA LIGERA PARED PROFESIONAL

Professional Concrete Light Hollow Core Bit
Trépan béton professionnel



Ø	SDS plus L110	SDS plus L110	SDS plus L220	SDS plus L350
Pcs	1	1	2	1
Ø	40	50	50	82
Pcs	1	1	1	1
Ø	65	68	80	82
Pcs	1	1	1	1

Ref. 4995 - Nº Art. 22418: 658,90 €

HERRAMIENTAS SDS MAX

SDS max Tools
Outils SDS max

Ref. **1892**

BROCA-MARTILLO SDS MAX 4 PUNTAS

4-Cutter SDS max Rotary Hammer Drill Bit
Foret percussion SDS max 4 pointes



SDS max

Marca desgaste
Wear Marking
Témoïn d'usure

Hormigón Reforzado
Reinforced Concrete
Béton armé

Hormigón Concrete
Béton

Hormigón Bloque
Concrete Block
Parpaing



2 puntas / 2-Cutter / 2-Taillants:

D mm	L mm	I mm	Nº Art.	€
12	340	200	30332	40,73
12	540	400	30333	47,76
12	690	550	30334	72,56
14	340	200	30335	44,06
14	540	400	30336	50,28
15	340	200	30337	47,60
15	540	400	30338	53,47

4 puntas 4-Cutter / 4-Taillants:

D mm	L mm	I mm	Nº Art.	€
16	340	200	30339	52,12
16	540	400	30340	59,66
16	940	800	60065	100,18
16	1320	1180	60066	191,85
18	340	200	30341	53,47
18	540	400	30342	65,37
18	940	800	60068	100,28
18	1320	1180	60070	197,80
20	320	200	30343	54,31
20	520	400	30344	70,38
20	920	800	30345	100,39
20	1320	1200	60072	236,98
22	320	200	30346	62,18
22	520	400	30347	73,90
22	920	800	30348	108,94
22	1320	1200	60075	253,22
24	320	200	30349	64,36
24	520	400	30350	79,10
25	320	200	30351	66,21
25	520	400	30352	80,45
25	920	800	30353	119,49
25	1320	1200	60077	258,03
26	520	400	30354	81,96
28	370	250	30355	79,78
28	570	450	30356	89,00
28	670	550	30357	109,94

D mm	L mm	I mm	Nº Art.	€
28	920	800	60079	132,56
30	370	250	30358	86,98
30	570	450	30359	92,68
32	370	250	30360	90,50
32	570	450	30361	112,78
32	920	800	30362	155,36
32	1320	1200	60085	275,05
35	370	250	30363	100,55
35	570	450	30364	120,51
35	670	550	30365	142,29
37	370	250	60088	105,86
37	570	450	60089	122,28
37	920	800	60090	180,39
38	370	250	30366	116,82
38	570	450	30367	124,03
38	720	600	79736	180,44
38	920	800	79737	190,85
40	370	250	30368	127,37
40	570	450	30369	145,81
40	920	800	30370	199,44
40	1320	1200	60093	316,87
45	570	450	30371	209,48
45	920	800	23981	288,38
50	570	450	52952	232,45
52	570	450	52954	282,66

Línea 1m
1892

BROCA-MARTILLO SDS MAX 4 PUNTAS

4-Cutter SDS max Rotary Hammer Drill Bit
Foret percussion SDS max 4 pointes



ø	16	16	18	18	20	20	22	22	25	25	28	28	30	30	32	35
	L340	L540	L340	L540	L320	L520	L320	L520	L320	L520	L370	L570	L370	L570	L570	L570
Pcs	1	1	1	1	1	1	1	1	1	1	1	1	1	1	1	1

Ref. 4995 - Nº Art. 72141: 1.304,59 €

Display 03

BROCA-MARTILLO SDS MAX 4 PUNTAS

4-Cutter SDS max Rotary Hammer Drill Bit
Foret percussion SDS max 4 pointes



∅	16 L540	18 L540	20 L520	22 L520	25 L520	28 L570	30 L570	32 L570	35 L570
Pcs	1	1	1	1	1	1	1	1	1

∅	12 L340	14 L340	16 L340	18 L340	20 L320	22 L320	25 L320	28 L370	30 L370
Pcs	1	1	1	1	1	1	1	1	1

Ref. 4995 - N° Art. 22315: 1.304,59 €

Display 33



49
cm

Display 34



68
cm

∅	12 L340	14 L340	16 L340	18 L340	20 L320	22 L320	25 L320	28 L370	30 L370
Pcs	1	1	1	1	1	1	1	1	1

Ref. 4995 - N° Art. 22618: 539,85 €

∅	16 L540	18 L540	20 L520	22 L520	25 L520	28 L570	30 L570	32 L570	35 L570
Pcs	1	1	1	1	1	1	1	1	1

Ref. 4995 - N° Art. 22619: 764,74 €

Ref. **1894**

CORONA SDS MAX

SDS max Core Cutter
Foret trépan SDS max

¡NUEVO MODELO MEJORADO!

New improved model!

Nouveau Modèle amélioré



SDS
max



Nuevo Diseño Especial Hormigón Reforzado
New Special Design for Reinforced Concrete
Nouveau Dessin pour Béton Armé

Hormigón
Concrete
Béton

Hormigón Bloque
Concrete Block
Parpaing

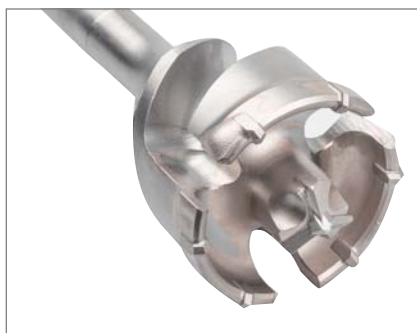

- Taladrado Exacto Auto-Centrante
- Dientes MD ► Rápida Penetración
- Gran Volumen Canales ► Mayor Evacuación del Polvo
- Auto-Centering Accurate Drilling
- Carbide Teeth ► Fast Penetration
- High Volume Flutes ► Better Dust-Removal
- Perçage Autocentreur Exact
- Dents Carbure ► Pénétration plus rapide
- Gran Volume des Goujures ► Meilleur évacuation copeaux

- Resistente al calentamiento.
- Apto para trabajo intensivo
- Heat-resistant.
- Intensive work.
- Resistance au rechauffement
- Idéal pour travaux intensifs.

D mm	L mm	I mm	Nº Art.	€
45	550	450	16864	285,27
45	990	890	16865	344,68
55	550	450	16868	329,64
55	990	890	16869	377,89
65	550	450	16870	355,40
65	990	890	16871	408,97
80	550	450	16873	395,97
80	990	890	16874	510,54

Ref. **1697**

CORONA PERFORADORA TALADRO PERCUTOR

Tapered Hollow Hammer Core Bit

Trépan pour perçuses percussion lourds



Diente MD
Carbide Tipped
Dent Carbure



SDS
max

Conicidad 1:8
1:8 Tapered
Conicité 1:8

Hormigón
Concrete
Béton



D mm	L mm	Nº Art.	€
40	100	19035	102,48
50	100	19041	124,02
65	100	19045	159,71
80	100	19047	183,28
90	100	19048	211,17
100	100	19050	229,18
125	100	19051	299,65

Ref. **1698**

Broca Centrar
Center Drill
Foret à centrer



00001

Broca Drill Bit Foret Mod.	D mm	L mm	Nº Art.	€
1	11	120	19054	8,72

Cuña Expulsora Ref. 1104
Drill Drift
Chasse



00002

CM min.	CM max.	L mm	Nº Art.	€
1	2	116	16436	10,59

Husillo SDS max
SDS max Spindle
Arbre SDS max



00003-4

SDS max Mod.	L mm	Nº Art.	€
3	180	19057	47,43
4	450	19058	84,28

Display
06

CORONA PERFORADORA TALADRO PERCUTOR

Tapered Hollow Hammer Core Bit

Trépan pour perçuses percussion lourds



ø	Llave Key / Clé	Broca Drill Bit / Foret	Broca Drill Bit / Foret	SDS max L180	SDS max L180	SDS max L450
Pcs	3	2	1	2	1	1
ø	40	50	65	80		
Pcs	1	1	1	1		

Ref. 4995 - Nº Art. 22463: 853,99 €

ADAPTADOR iCONNECT

iConnect Adaptor Adaptateur iConnect

Descripción

iConnect permite taladrar agujeros extremadamente profundos con una broca-martillo corta, de una manera mucho más económica gracias a su sistema de adaptadores y alargadores.

Estos alargadores permiten incluso la combinación de un taladro SDS plus con una broca SDS max.

Ventajas

- 2 clicks y ya tiene la broca de la longitud que necesita
- Las dos entradas SDS max del adaptador consiguen una conexión rápida y segura entre la broca y los diferentes alargadores
- Con el adaptador iConnect no hay pérdida de energía, algo habitual en otros sistemas tradicionales de adaptadores
- No hay posibilidad de rotura por causa de una excesiva presión en el área de unión
- Reducción al mínimo de las herramientas necesarias para el taladrado profesional

Uso

Hormigón, pared y piedra natural

Description

iConnect allows drilling extremely deep holes with a short hammer drill bit, in very inexpensive way thanks to this system of adaptors and extensions.

These extensions allow even the combination of a SDS plus drilling machine with a SDS max rotary hammer drill bit.

Advantages

- 2 clicks and the tools is the required length
- The adaptor's two SDS max chucks provide a quick and safe connection between the drilling tool and the extension shanks
- With the iConnect adaptor there is no energy loss, normally encountered in traditional adapter systems
- Breakages because of excessive strain in the coupling area are not possible
- Professional drilling tool requirements reduced to a minimum

Use

Concrete, masonry and natural stone

Description

IConnect permet percer des trous très profonds avec un foret percussion court, d'une façon beaucoup plus économique grâce à son système d'adaptateurs et rallonges.

Ces rallonges permettent aussi une combiner un perçage SDS PLUS avec un foret SDS Max.

Avantages

- En 2 clicks vous obtenez la longueur du foret que vous avez besoin.
- Les 2 entrées SDS MAX de l'adaptateur vous permettent une connexion rapide entre le foret et les différents rallonges.
- Avec l'adaptateur IConnect pas de perte d'énergie, comme dans d'autres systèmes.
- Pas de rupture à cause d'une haute pression dans la zone de la conéxion d'union.
- Réduire au minimum les outils pour le perçage professionnel.

Emploi

Béton Armé, Béton et Pierre.

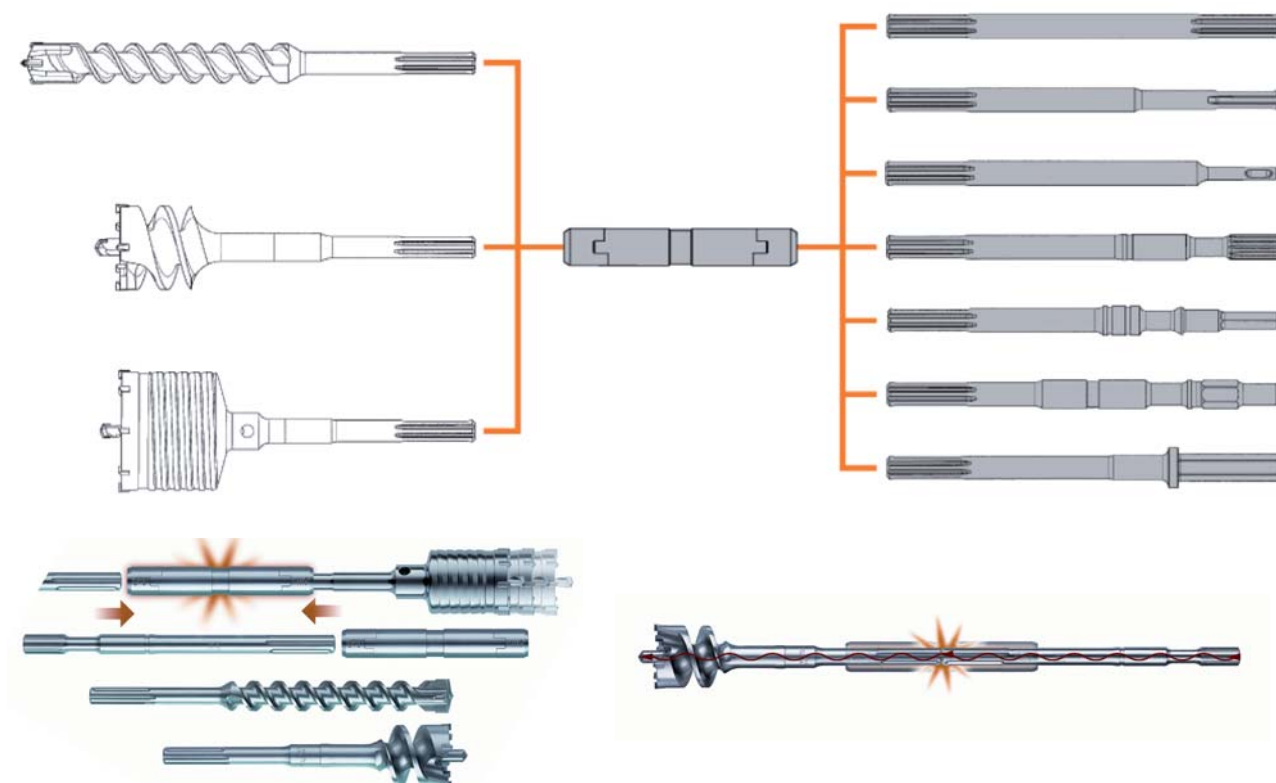

Ref. **1875**

ADAPTADOR SDS MAX

SDS max Adaptor
Adaptateur SDS max



SDS
max



Hormigón
Concrete
Béton

Hormigón Bloque
Concrete Block
Parpaing



Adaptador Mod.	L mm	d mm	Nº Art.	€
1	190	30	56810	223,55



Extensión MAX-MAX Mod.	L mm	Nº Art.	€
0320-MAX	320	56811	37,70
0750-MAX	750	56812	47,28
1100-MAX	1100	56813	63,78



Extensión MAX-PLUS Mod.	L mm	Nº Art.	€
0320-PLUS	320	56814	41,45
0750-PLUS	750	56815	52,76



Grasa Grease / Graisse Mod.	Nº Art.	€
2	57504	5,51

CINCELES

Chisels

Burins

Ref. **1870**

CINCEL SDS PLUS

SDS plus Chisel



Burin SDS plus



SDS plus

Hormigón Reforzado
Reinforced Concrete
Béton armé

Hormigón
Concrete
Béton

	Mod.	Tipo Type / Type	L mm	I mm	Nº Art.	€
 Puntero / Pointed / Ciseau	00001-250	Puntero / Pointed / Ciseau	250		30372	6,94
 Plano / Flat / Plate	00002-250	Plano / Flat / Plate	250	20	30373	6,94
 Ancho / Wide / Large	00003-200038	Ancho / Wide / Large	200	38	30374	11,89
 Hueco / Hollow / Gouge	00004-240	Hueco / Hollow / Gouge	240	22	30375	14,34
 Alas / Wing-Canal / Ailes	00005-250	Alas / Wing-Canal / Ailes	250	22	54983	34,67
 Azulejo / Tile / Carreau	00009-200038	Azulejo Tile / Carreau	200	38	54985	13,60
	00009-250060		250	60	54986	34,89
 Dentado / Slotting / Denté	00010-200032TCT	Dentado / Slotting / Denté	200	32	54988	92,47
 Ancho / Wide / Large	00011-250040	Ancho / Wide / Large	250	40	82692	15,45

Reafilable
Resharpenable
Réaffûtable

Ref. **1872**

CINCEL SDS MAX

SDS max Chisel
Burin SDS max



SDS
max

Hormigón Reforzado
Reinforced Concrete
Béton armé

Hormigón
Concrete
Béton



Puntero / Pointed / Ciseau



Plano / Flat / Plate



Ancho / Wide / Large



Hueco / Hollow / Gouge



Alas / Wing-Canal / Ailes



Acanalador / Canal / Gouge-Brique



Azulejo / Tile / Carreau



Dentado / Slotting / Denté



Pala / Clay-Spade / Pelle

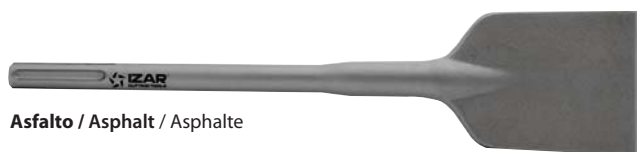

Asfalto / Asphalt / Asphalte



Abujardar / Bushing / Bouchardage

Mod.	Tipo Type / Type	L mm	I mm	Nº Art.	€
00001-280	Puntero Pointed / Ciseau	280		54989	9,92
00001-400		400		30376	11,76
00001-600		600		23036	15,85
00002-280	Plano Flat / Plate	280	24	54990	9,92
00002-400		400	24	30377	11,76
00002-600		600	24	23037	15,85
00003-360050	Ancho Wide / Large	360	50	23038	17,50
00003-300080		300	80	30378	26,27
00003-350115		350	115	54991	53,69
00004-300	Hueco Hollow / Gouge	300	26	30379	29,17
00005-380035	Alas Wing-Canal / Ailes	380	35	18186	64,63
00008-300032	Acanalador Canal / Gouge-Brique	300	32	54993	32,36
00009-300050	Azulejo Tile / Carreau	300	50	54994	27,80
00009-300080		300	80	54996	29,17
00010-280038TCT	Dentado Slotting / Denté	280	38	54999	86,56
00011-400110	Pala Clay-Spade / Pelle	400	110	55000	70,67
00012-400090	Asfalto Asphalt / Asphalte	400	90	55003	68,25
00013-240045	Abujardar Bushing Bouchardage	240	45x 45	55004	111,53



Línea 33 cm
1870

CINCEL SDS PLUS

SDS plus Chisel
Burin SDS plus



	Puntero Pointed Ciseau	Plano Flat Plate	Ancho Wide Large	Hueco Hollow Gouge
∅				
Pcs	2	2	2	2

Ref. 4995 - N° Art. 71023: **80,22 €**

Display
04

CINCELES SDS MAX / PLUS

SDS max / plus Chisels
Burins SDS max / plus



SDS MAX Ref. 1872

	Puntero Pointed Ciseau L400	Plano Flat Plate L400	Ancho Wide Large 50	Ancho Wide Large 80	Hueco Hollow Gouge	Alas Wing-Canal Ailes L380	Puntero Pointed Ciseau L600	Plano Flat Plate L600
∅								
Pcs	2	2	2	2	2	2	1	1

Display
35

Ref. 4995
N° Art. 22621
353,85 €

SDS PLUS Ref. 1870

	Puntero Pointed Ciseau	Puntero Pointed Ciseau	Plano Flat Plate	Plano Flat Plate	Ancho Wide Large	Ancho Wide Large	Hueco Hollow Gouge	Hueco Hollow Gouge
∅								
Pcs	1	1	1	1	1	1	1	1

Display
36

Ref. 4995
N° Art. 22623
80,22 €

Ref. 4995 - N° Art. 22289: **434,06 €**

Ref. **1871**

CINCEL HEXAGONAL 30 mm

HEX Shank Chisela
Burin hexagonal

New!



Hormigón Reforzado
Reinforced Concrete
Béton armé

Hormigón
Concrete
Béton

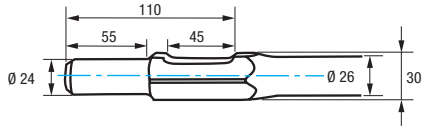

Puntero / Pointed / Ciseau



Plano / Flat / Plate

Mod.	Tipo Type / Type	L mm	I mm	Nº Art.	€
00001-400	Puntero / Pointed / Ciseau	400		70710	33,01
00002-400	Plano / Flat / Plate	400	75	70712	59,38



BROCAS MANGO CILÍNDRICO

Straight Shank Drill Bits
Forets queue cylindrique

Ref. **1882**

BROCA PORCELÁNICO

PORCELAIN Drill Bit
Foret PORCELAINE

¡MODELO EXCLUSIVO!



Video



Sin percusión
No percussion
Sans percussion



H₂O
Refrigerar punta
Point Cooling
Refrroidir la pointe



Porcelánico
Porcelain
Porcelaine

Teja, piedra, pizarra, cemento, terrazo, mármol, terracota, calizas
Tile, quarry, slate, cement, terrazzo, marble, terracotta, limestones
Tuile, pierre, ardoise, ciment, terrazzo, marbre, terre cuite, calcaires



D mm	L mm	l mm	d mm		Nº Art.	€
3,00	85	50	3,0	1	13903	12,34
3,50	85	50	3,0	1	13906	12,34
4,00	85	50	3,5	1	13909	12,34
4,50	85	50	4,0	1	13910	12,34
5,00	85	50	4,5	1	14030	13,05
6,00	100	65	5,5	1	14036	13,66
7,00	125	75	6,5	1	14061	15,62
8,00	125	75	7,5	1	14062	16,92
9,00	150	90	8,5	1	14063	20,53
10,00	150	90	9,5	1	14066	20,53
11,00	150	90	10,0	1	14068	26,64



Doble Blister
ref. M882
pag. 375



Ref. **1482**

4 Pcs

Cont. Ø	Nº Art.	€
4-5-6-8 mm	31004	57,64



Display
1882

Display Sobremesa
Table Display
Pres. Comptoir

Display
37



29
cm

ø	3	4	5	5	6	6	7	8	8	9	10
Pcs	4	4	5	5	5	5	4	2	2	4	4

Ref. 1882 - Nº Art. 22661: 660,25 €

ø	4	4	5	5	6	6	8	8	10	10
Pcs	2	2	2	2	2	2	2	2	2	2

Ref. 4995 - Nº Art. 22620: 306,01 €

Display especial Porcelánico

Display
70

BROCA, BROCA-CORONA, CORONA DIAMANTE PORCELÁNICO

Porcelain Diamond Core Bit & Drill Bit

Foret, Foret-Trépan et Trépan Diamant PORCELAINE



Ref. 1882	Ø	4	5	5	6	6	8	8	10
	Pcs	2	3	2	5	5	3	2	2
Ref. 1879	Ø	5	6	6	8	8	10	12	14
	Pcs	5	3	3	2	2	2	1	1
Ref. 1883	Ø	6	8	10	20	25	32	35	
	Pcs	1	1	1	1	1	1	1	1

Ref. 4995 - Nº Art. 82239: 1.078,50 €

Ref. 1879

BROCA-CORONA DIAMANTE PORCELÁNICO

Porcelain Diamond Core Bit

Foret-Trépan diamant PORCELAINE



H₂O
Refrigerar punta
Point Cooling
Refroidir la pointe



Porcelánico
Porcelain
Porcelaine

Uso / Use / Usage

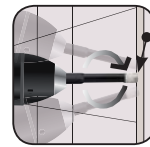
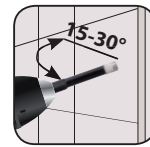

D	d	L	l		Nº	€
mm	mm	mm	mm		Art.	
5,00	8,30	68	10	1	56664	14,82
6,00	8,30	68	10	1	56665	15,51
8,00	8,30	80	10	1	56667	19,22
10,00	8,30	80	10	1	56668	23,31
12,00	8,30	80	10	1	56670	25,82
14,00	8,30	80	10	1	56671	29,85



Set 5 Pcs

Cont. Ø	Nº Art.	€
5-6-8-10-12 mm	57448	98,68

Línea 33 cm
1879

BROCA-CORONA DIAMANTE PORCELÁNICO

Porcelain Diamond Core Bit

Foret-Trépan diamant PORCELAINE



19
cm

Ø	5	6	8	10	12	14
Pcs	3	3	3	3	3	3

Ref. 4995 - Nº Art. 71026: 385,62 €

Ref. **1883**

CORONA DIAMANTE PORCELÁNICO

Porcelain Diamond Core Bit
Trépan diamant PORCELAINE



Porcelánico
Porcelain
Porcelaine



Video

Aplicación

Taladrado limpio de agujeros exactos en placas de piedra, azulejos, cerámicas, dekon y piedra artificial dura. Especial para Porcelánico.

Atención

Comenzar a taladrar con cuidado por un lado y redirigir poco a poco hacia un taladrado completo.

Consejo

Puede conseguir un mejor rendimiento con leves movimientos oscilantes a la corona mientras corta.

Application

Clean drilling of exact and Sharp holes in stone plates, tiles, ceramics, dekon and hard artificial stone. Special for Porcelain.

Please note

Start drilling carefully edgewise and slowly continue with full drilling.

Tip

With small tilting movements of the core drill the cutting performance can be improved.

Application

Perçage trous précision sur tôles pierre, carreaux de faïence, céramiques et dekon. Spécial pour porcelaine.

Attention

Commencer à percer doucement et rediriger petit à petit vers un perçage complet.

Conseil

Vous pouvez avoir une meilleure performance avec faibles mouvements variables sur le trépan dans la coupe.

Diámetros más usuales

35 mm: Grifería
40 mm: Desagües electrodomésticos
50 mm: Desagües industriales
60 mm: Cajas eléctricas

Most usual diameters

35 mm: Water Taps
40 mm: Appliances Pipes
50 mm: Industrial Pipes
60 mm: Electrical Boxes

Diamètres plus usuels

35 mm: Robinetterie
40 mm: Déversoirs ménage
50 mm: Déversoirs industriels
60 mm: Boîtes électriques

D mm	L mm	Rosca Thread Filet	Nº Art.	€
6	63	M14	34506	36,35
8	63	M14	34353	37,38
10	63	M14	34507	41,48
12	63	M14	34508	45,56
14	63	M14	55532	54,79
16	90	M14	81515	55,30
18	90	M14	55533	55,81
20	90	M14	55534	56,83
25	90	M14	55535	64,00
32	90	M14	55536	71,17

D mm	L mm	Rosca Thread Filet	Nº Art.	€
35	90	M14	34510	72,71
40	90	M14	34511	84,99
45	90	M14	55538	94,21
50	90	M14	34512	101,89
55	90	M14	55539	107,53
60	90	M14	34513	108,05
68	90	M14	55541	118,78
75	90	M14	34516	131,08
82	90	M14	55542	142,86
110	90	M14	69797	258,97

Línea 1m
1883

CORONA DIAMANTE PORCELÁNICO

Porcelain Diamond Core Bit
Trépan diamant PORCELAINE



Ø	6	8	10	12	14	18	20	25	32	35	40	45	50
Pcs	1	1	1	1	1	1	1	1	1	1	1	1	1

Ref. 4995 - Nº Art. 72145: **817,19 €**

Ref. **1877**

BROCA GRANITO

Granite Drill Bit
Foret Granite



BlackGranite



H₂O
Refrigerar punta
Point Cooling
Refroidir la pointe

Granito
Granite
Granite

Piedra
Stone
Pierre

Mármol
Marble
Marbre

Silestone

- Ideal para piedras de todo tipo hasta granitos de gran dureza.
- Ideal for all types of stones, from general ones to hard granites.
- Idéal pour tous les types de pierres jusqu'aux granites difficiles à percer.

- El uso de refrigeración con agua permite una mayor eficiencia de corte y durabilidad. También apto en seco.
- Better performance and durability if cooled using water when drilling. Dry cutting also possible
- Le refroidissement à eau permet une meilleure efficacité de coupe et une meilleure durabilité. Coupe à sec également possible.

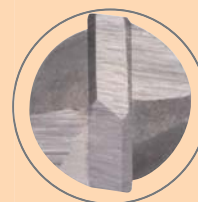
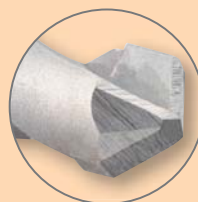

- **Forma de filo asimétrico.**
El rectificado asimétrico de la punta de metal duro reduce la resistencia al corte, permitiendo una perforación del material de trabajo con menor esfuerzo de torsión.
- **Asymmetric cutting edge shape.**
The asymmetric grinding of the carbide tip reduces cutting resistance, allowing the work material drilling with a lower torque.
- **Arête de coupe asymétrique.**
La réctification asymétrique de la pointe en carbure réduit la résistance à la coupure, permettant le perçage du matériau de travail avec une torsion plus faible.

D mm	L mm	l mm	d mm	RPM		Nº Art.	€
3,00	85	50	3,00	2000-2500	1	76539	9,33
3,50	85	50	3,00	2000-2500	1	76540	9,33
4,00	85	50	3,50	2000-2500	1	76543	9,33
4,50	85	50	4,00	2000-2500	1	76544	9,33
5,00	85	50	4,50	2000-2500	1	76545	9,87
6,00	100	65	5,50	1500-2000	1	76547	9,87
7,00	125	75	6,50	1500-2000	1	76548	11,81
8,00	125	75	7,50	1000-1500	1	76549	12,79
9,00	150	90	8,50	1000-1500	1	76550	15,51
10,00	150	90	9,50	1000-1500	1	76553	15,51

Display
69



29
cm

ø	4	4	5	5	6	6	8	8	10	10
Pcs	2	2	3	3	3	3	3	3	2	2

Ref. 4995 - Nº Art. 81880: 294,53 €

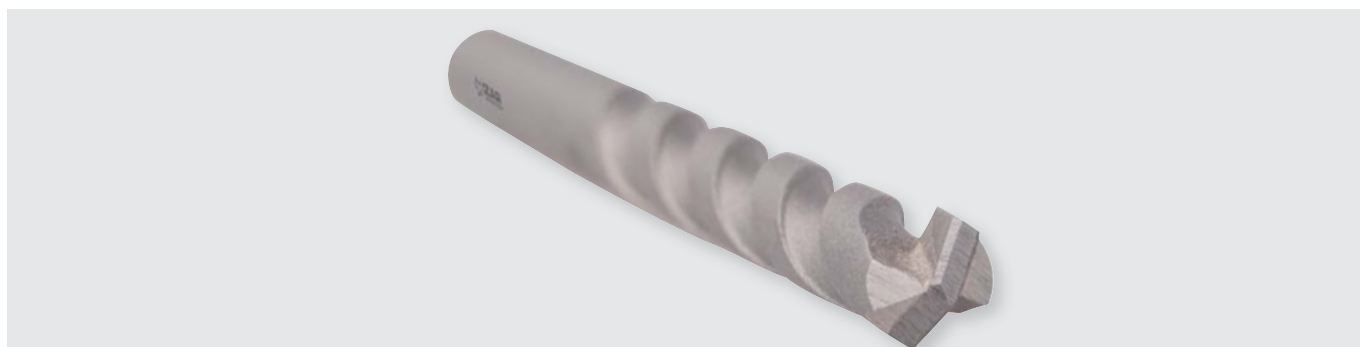

Ref. **1886**

BROCA PUNTA METAL DURO PARED PROFESIONAL

Professional Concrete Carbide Tipped Drill Bit
Foret pointe carbure béton professionnel



MD/HM
TCT



Hormigón
Concrete
Béton

Hormigón Bloque
Concrete Block
Parpaing

D mm	L mm	I mm		Nº Art.	€
3,0	60	35	1	30232	1,85
4,0	75	45	1	18525	1,85
5,0	85	40	1	18526	1,88
5,5	85	40	1	23983	1,95
6,0	100	55	1	18528	2,03
6,5*	100	55	1	23984	2,21
7,0	100	55	1	18529	2,42
8,0	120	70	1	18531	2,71
9,0	120	70	1	18532	3,40
10,0	120	70	1	18534	3,40
11,0	150	90	1	17858	4,37
12,0	150	90	1	18535	5,10
13,0	150	90	1	30234	6,38
14,0	150	90	1	18537	7,52
16,0	150	90	1	30235	13,70

D mm	L mm	I mm		Nº Art.	€
5,0	150	80	1	30176	2,60
6,0	150	80	1	30200	3,19
8,0	200	130	1	30208	4,93
10,0	200	130	1	30214	6,08
12,0	200	130	1	30222	6,20



Doble Blister
ref. M886
pag. 376

* Diam. hasta fin de existencias / while stock lasts / jusqu'à la fin de stock

Línea 1m
1886

BROCA PUNTA METAL DURO PARED PROFESIONAL

Professional Concrete Carbide Tipped Drill Bit
Foret pointe carbure béton professionnel



ø	3	4	5	6	7	8	9	10	12	14	16
Pcs	10	10	10	10	10	10	10	10	10	10	10

Ref. 4995 - Nº Art. 71100: 458,73 €



Ref. **1846**

BROCA PUNTA METAL DURO PARED PRO EXTRA LARGA

Extra Long Professional Concrete Carbide Tipped Drill Bit
Foret pointe carbure béton professionnel extra-longue



MD/HM
TCT



Serie Extra Larga
Extra Long Series
Série extra-longue

Hormigón
Concrete
Béton

Hormigón Bloque
Concrete Block
Parpaing

D mm	L mm	I mm		Nº Art.	€
6	400	300	1	30202	5,75
8	400	300	1	30212	5,75
10	400	300	1	30216	6,02
12	400	300	1	30227	6,47
14	400	300	1	30233	8,23
16	400	300	1	30237	14,39
18	400	300	1	30207	18,00
20	400	300	1	30225	19,94
22	400	300	1	16474	22,94
24	400	300	1	16475	23,75
25	400	300	1	16476	27,13

D mm	L mm	I mm		Nº Art.	€
8	600	450	1	76910	9,41
10	600	450	1	30218	9,85
12	600	450	1	30229	10,74
14	600	450	1	30236	13,01
16	600	450	1	30238	16,60
18	600	450	1	16477	22,33
20	600	450	1	16478	25,91

Línea 1m
1846

BROCA PUNTA METAL DURO PARED PRO EXTRA LARGA

Extra Long Professional Concrete Carbide Tipped Drill Bit
Foret pointe carbure béton professionnel extra-longue



ø	6	8	10	12	14	16	18	20	22	24	25	10	12	14	16	18	20
	L400	L400	L400	L400	L400	L400	L400	L400	L400	L400	L400	L600	L600	L600	L600	L600	L600
Pcs	2	2	2	2	2	2	2	1	1	1	1	2	2	2	2	2	1

Ref. 4995 - Nº Art. 72150: 393,93 €

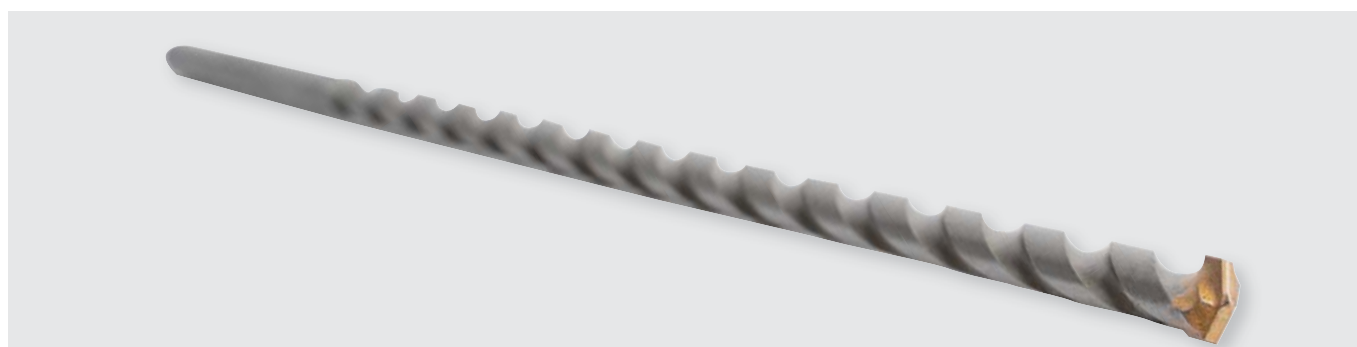

Display 07



BROCA PUNTA METAL DURO PARED PROFESIONAL

Professional Concrete Carbide Tipped Drill Bit
Foret pointe carbure béton professionnel

∅	12 L200	8 L400	10 L400	12 L400	14 L400	16 L400	18 L400	20 L400		
Pcs	3	3	3	3	3	3	2	2		
∅	10 L120	12 L150	14 L150	16 L150	5 L150	6 L150	8 L200	10 L200		
Pcs	5	5	5	5	5	5	5	3		
∅	3 L60	4 L75	5 L85	5 L85	6 L100	6 L100	7 L100	8 L120	8 L120	9 L120
Pcs	10	10	5	5	5	5	5	5	5	

Ref. 4995 - N° Art. 22191: 569,85 €

Display 52 Mixto PRO



BROCAS MULTI INOX + PARED PRO + MADERA PRO

Multi-Stainless + Concrete Pro + Wood Pro Drill Bits
Forets Multi INOX + béton pro + bois pro

Ref. 1886	∅	3	4	5	6	7	8	9	10	12	14
	Pcs	5	5	10	10	5	5	3	3	3	3
Ref. 1641	∅	3	3	4	4	5	5	6	6	8	10
	Pcs	3	2	3	2	3	2	3	2	5	5
Ref. 1004	∅	1	2	3	3,5	4	4,5	5	6	8	10
	Pcs	2	2	3	3	5	5	5	5	5	3

Ref. 4995 - N° Art. 68575: 463,36 €

Display 23



JUEGOS CASSETTE MADERA Y CONSTRUCCIÓN

Wood & Construction Cassette Sets
Jeux cassette bois & construction

Constr. Madera Wood / Bois	Pcs	Ref. 1485 Pared Masonry / Béton 5 Pcs.	Ref. 1486 Pared Pro Masonry Pro / Béton Pro 5 Pcs.	Ref. 1435 Madera Wood / Bois 5 Pcs.	Ref. 1438 Madera Wood / Bois 8 Pcs.
		5	5	5	5
Constr.	Pcs	Ref. 1488 Pared Masonry / Béton 8 Pcs.	Ref. 1487 Pared Pro Masonry Pro / Béton Pro 8 Pcs.	Ref. 1494 SDS plus 4 Pcs.	
		5	5	3	

Ref. 4995 - N° Art. 22372: 395,50 €

Sets 1886

BROCA PUNTA METAL DURO PARED PROFESIONAL

Professional Concrete Carbide Tipped Drill Bit
Foret pointe carbure béton professionnel



Set **1486**

5 Pcs

Cont. Ø	Nº Art.	€
4-5-6-8-10 mm	30220	13,70



Set **1487**

8 Pcs

Cont. Ø	Nº Art.	€
3-4-5-6-7-8-9-10 mm	21653	22,51

Línea 33 cm 14S1

SETS BROCAS METAL, PARED PRO, PARED, MADERA

Metal, Concrete, Masonry, Wood Sets
Jeux métal, béton, maçonnerie, bois



	Metal Metal Métal	Pared Pro Concrete Béton	Pared Masonry Maçonnerie	Madera Wood Bois
Ref	1462-1010	1486	1485	1435
Diam	2-3-4-5-6-8 mmm	4-5-6-8-10 mm	4-5-6-8-10 mm	4-5-6-8-10 mm
Pcs.	5	5	5	5

Ref. 4995 - Nº Art. 72193: **170,80 €**

Línea 33 cm 14S2

SETS BROCAS HORMIGÓN, PARED PRO, PARED

Concrete, Masonry Sets
Jeux Béton, Maçonnerie



	Hormigón Concrete Béton	Pared Pro Concrete Béton	Pared Masonry Maçonnerie
Ref	1494	1487	1488
Diam	5/6x110 + 8/10x160 mm	3-4-5-6-7-8-9-10 mm	3-4-5-6-7-8-9-10 mm
Pcs.	3	5	5

Ref. 4995 - Nº Art. 72194: **217,44 €**

Ref. **1880**

BROCA PUNTA METAL DURO PARED STANDARD

Standard MASONRY Carbide Tipped Drill Bit
Foret pointe carbure MAÇONNERIE standard



MD/HM
TCT



Ladrillo
Brick
Brique

D mm	L mm	l mm	d mm		Nº Art.	€	D mm	L mm	l mm	d mm		Nº Art.	€
3	60	30	2,5	1	18495	0,73	13	150	95	10,0	1	30180	2,75
4	75	40	3,2	1	18496	0,74	14	150	95	10,0	1	18508	3,55
5	85	50	4,0	1	18498	0,83	16	150	95	14,0	1	30184	5,48
6	100	60	4,8	1	18499	0,93	18	160	105	16,0	1	30188	6,26
7	100	60	5,2	1	18501	1,06	20	160	105	18,0	1	30190	7,69
8	120	80	6,2	1	18502	1,16	22	160	105	19,0	1	30192	9,00
9	120	80	7,5	1	18504	1,32	25	160	105	22,5	1	30194	11,13
10	120	80	7,5	1	18505	1,42							
11	150	85	8,5	1	30178	2,25							
12	150	85	8,5	1	18507	2,42							

D mm	L mm	l mm	d mm		Nº Art.	€	D mm	L mm	l mm	d mm		Nº Art.	€
5	150	85	4,0	1	30174	1,35	6	200	135	4,8	1	30198	1,73
6	150	85	4,8	1	30196	1,44	8	200	135	7,5	1	30211	2,01
							10	200	135	8,5	1	30412	2,72
							12	200	135	8,5	1	30224	3,32
							14	200	135	12,0	1	30228	4,22



Línea 1m
1880

BROCA PUNTA METAL DURO PARED STANDARD

Standard MASONRY Carbide Tipped Drill Bit
Foret pointe carbure MAÇONNERIE standard



ø	3	4	5	6	7	8	9	10	12	14
Pcs	10	10	10	10	10	10	10	10	10	10

Ref. 4995 - Nº Art. 71032: **141,54 €**

Display 08



BROCA PUNTA METAL DURO PARED

MASONRY Carbide Tipped Drill Bit
Foret pointe carbure MAÇONNERIE

Ref. 1880	∅	16 L150	5 L150	6 L150	6 L200	8 L200	10 L200	12 L200	14 L200		
	Pcs	5	5	10	10	10	5	5	5		
Ref. 1485	∅	3 L60	4 L75	5 L85	6 L100	7 L100	8 L120	9 L120	10 L120	12 L150	14 L150
	Pcs	10	10	10	10	10	10	5	5	5	5
Ref. 1485 1488	∅	Ref. 1485			Ref. 1488			Ref. 1485			
	Pcs	5			5			5			

Ref. 4995 - N° Art. 22311: 354,81 €

Display 09



BROCAS PARED, VIDRIO, UNIVERSAL

Masonry, Glass, Universal Drill Bits
Forets maçonnerie, verre, universel

Ref. 1880	∅	3 L60	4 L75	5 L85	6 L100	7 L100	8 L120	9 L120	10 L120	12 L150	14 L150
	Pcs	5	5	10	10	5	6	3	3	3	3
Ref. 1836	∅	3	4	4	5	5	6	6	8	8	10
	Pcs	5	3	2	3	2	3	2	3	2	5
Ref. 1881	∅	4	5	6	6	8	8	10	12		
	Pcs	5	5	5	5	3	2	5	5		

Ref. 4995 - N° Art. 22410: 504,91 €



Display 51



BROCAS METAL + PARED + MADERA

Metal + Masonry + Wood Drill Bits
Forets métal + maçonnerie + bois

Ref. 1880	∅	3	4	5	6	7	8	9	10	12	14
	Pcs	10	10	10	10	10	10	5	5	5	5
Ref. 1640	∅	3	4	5	6	8	9	10	12	14	16
	Pcs	10	10	10	10	10	5	5	5	5	5
Ref. 1001	∅	1	2	3	3,5	4	4,5	5	6	8	10
	Pcs	10	10	10	10	10	10	10	5	5	3

Ref. 4995 - N° Art. 68572: **333,01 €**

Display 59



BROCAS SPEED POINT + PARED + MADERA

Speed Point + Masonry + Wood Drill Bits
Forets speed point + maçonnerie + bois

Ref. 1880	∅	3	4	5	6	7	8	9	10	12	14
	Pcs	10	10	10	10	10	10	5	5	5	5
Ref. 1640	∅	3	4	5	6	8	9	10	12	14	16
	Pcs	10	10	10	10	10	5	5	5	5	5
Ref. 1002	∅	2	3	3,5	4	4,5	5	6	7	8	10
	Pcs	10	10	10	10	10	10	5	5	5	3

Ref. 4995 - N° Art. 70099: **334,26 €**

Sets
1880

BROCA PUNTA METAL DURO PARED STANDARD

Standard MASONRY Carbide Tipped Drill Bit
Foret Pointe carbure MAÇONNERIE standard



Set **1485**

5 Pcs

Cont. Ø	Nº Art.	€
4-5-6-8-10 mm	30215	6,84

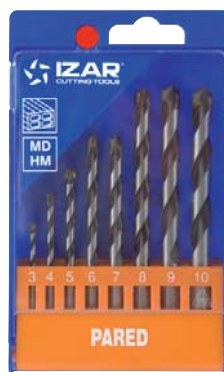

Set **1488**

8 Pcs

Cont. Ø	Nº Art.	€
3-4-5-6-7-8-9-10 mm	30219	10,23

Línea 33 cm
14S1

SETS BROCAS METAL, PARED PRO, PARED, MADERA

Metal, Concrete, Masonry, Wood Sets
Jeux métal, béton, maçonnerie, bois



23 cm

	Metal Metal Métal	Pared Pro Concrete Béton	Pared Masonry Maçonnerie	Madera Wood Bois
Ref	1462-1010	1486	1485	1435
Diam	2-3-4-5-6-8 mm	4-5-6-8-10 mm	4-5-6-8-10 mm	4-5-6-8-10 mm
Pcs.	5	5	5	5

Ref. 4995 - Nº Art. 72193: **170,80 €**

Línea 33 cm
14S2

SETS BROCAS HORMIGÓN, PARED PRO, PARED

Concrete, Masonry Sets
Jeux béton, maçonnerie



26 cm

	Hormigón Concrete Béton	Pared Pro Concrete Béton	Pared Masonry Maçonnerie
Ref	1494	1487	1488
Diam	5/6x110 + 8/10x160 mm	3-4-5-6-7-8-9-10 mm	3-4-5-6-7-8-9-10 mm
Pcs.	3	5	5

Ref. 4995 - Nº Art. 72194: **217,44 €**

Ref. **1460**

SET MIXTO BROCAS

Drill Bit Mix Set
Jeu forets mix



9 Pcs

Cont. Ø	Nº Art.	€
3 Pcs Metal: 5-6-8 3 Pcs Madera/Wood/Bois: 5-6-8 3 Pcs Pared/Masonry/Béton 5-6-8	55610	10,60

Ref. **1881**

BROCA UNIVERSAL

UNIVERSAL Drill Bit
Foret UNIVERSEL

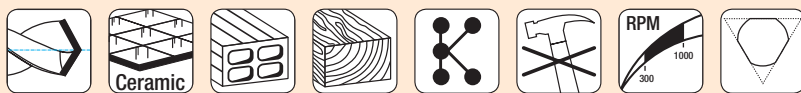

Plásticos
Plastics
Plastiques

Cerámica
Ceramics
Céramique

Ladrillo
Brick
Brique

Madera
Wood
Bois

D mm	L mm	I mm		Nº Art.	€
4	103	50	1	19065	5,52
5	112	50	1	19066	5,09
6	123	60	1	19069	5,32
8	134	80	1	19072	6,21
10	135	80	1	19075	7,65
12	153	90	1	19076	9,68



Línea 33 cm
1881

BROCA UNIVERSAL

UNIVERSAL Drill Bit
Foret UNIVERSEL



∅	4	5	6	8	10	12
Pcs	5	6	5	5	5	5

Ref. 4995 - Nº Art. 71034: 197,38 €



Display 09



BROCAS PARED, VIDRIO, UNIVERSAL

Masonry, Glass, Universal Drill Bits
Forets maçonnerie, verre, universel

Ref. 1880	∅	3	4	5	6	7	8	9	10	12	14
	Pcs	L60	L75	L85	L100	L100	L120	L120	L120	L150	L150
Ref. 1836	∅	3	4	4	5	5	6	6	8	8	10
	Pcs	5	3	2	3	2	3	2	3	2	5
Ref. 1881	∅	4	5	6	6	8	8	10	12		
	Pcs	5	5	5	5	3	2	5	5		

Ref. 4995 - N° Art. 22410: 504,91 €

Ref. 1889

BROCA UNIVERSAL

UNIVERSAL Drill Bit
Foret UNIVERSEL

D mm	L mm	l mm		N° Art.	€ 1 ud.
5	112	50	10	21925	4,59
6	123	60	10	21926	4,77
8	134	80	10	21927	5,58



Ref. **1836**

BROCA VIDRIO

GLASS Drill Bit
Foret VERRE



MD
HM



Vidrio
Glass
Verre

Cerámica
Ceramics
Céramique

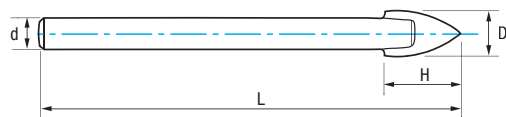

D mm	d mm	L mm	H mm		Nº Art.	€
3	2,80	58	6	1	30239	5,35
4	3,20	64	8	1	30240	5,88
5	4,00	70	10	1	30241	6,24
6	4,80	76	12	1	30242	6,61
8	6,20	83	16	1	30243	8,09
10	7,50	90	20	1	30244	11,34



Línea 33 cm
1836

BROCA VIDRIO

GLASS Drill Bit
Foret VERRE



ø	3	4	5	6	8	10
Pcs	5	5	5	5	5	5

Ref. 4995 - Nº Art. 71037: 217,59 €

Ref. **1699**

PUNTERO MARCADOR

Pencil Scriber
Traçeur carbure



MD/HM
TCT



Aceros
Steel
Aciers

Madera
Wood
Bois

Cerámica
Ceramics
Céramique

	Nº Art.	€
1	18856	4,70

Ref. **1601**

BROCA PARED

Masonry Drill Bit
Foret maçonnerie



MD/HM
TCT



D mm	L mm	l mm	d mm		Nº Art.	€
4,00	75	40	6,35	1	55997	2,36
5,00	85	50	6,35	1	55998	2,50
6,00	100	60	6,35	1	55999	2,69
8,00	120	80	6,35	1	56000	3,58
10,00	120	80	6,35	1	56001	4,51

Línea 33 cm
1601

BROCA PARED

Masonry Drill Bit
Foret maçonnerie



∅	4	5	6	8	10
Pcs	5	5	5	5	5

Ref. 4995 - Nº Art. 72200: **78,26 €**

Display
54

BROCAS METAL + PARED + MADERA

Metal + Masonry + Wood Drill Bits
Forets Métal + Maçonnerie + Bois



		Ref. 1611							
∅		2	3	3,25	3,5	4	5	6	8
Pcs		3	3	3	3	3	3	3	3
		Ref. 1610						Ref. 1601	
∅		M3	M4	M5	M6	M8	M10	4	5
Pcs		2	2	2	2	2	2	3	3
		Ref. 1601			Ref. 1621				
∅		6	8	10	3	4	5	6	8
Pcs		3	3	3	3	3	3	3	3

Ref. 4995 - Nº Art. 69804: **475,64 €**



Ref. **1461**

SET BROCAS MANGO HEXAGONAL 1/4" Y PUNTAS DE ATORNILLAR

Hexagonal Shank Drill Bit and Screwdriver Bit Set
Jeu de forets hexagonales et embouts vissage



42
pcs



Brocas rectificadas Metal Mango HEX
HEX Shank Metal Ground Drill Bits
Forets rectifiés métal queue HEX
2 - 2,5 - 3 - 3,5 - 4 - 5 - 6 mm

Brocas Pared
Masonry Drill Bits
Forets maçonnerie
4 - 5 - 6 - 8 mm

Brocas Madera
Wood Drill Bits
Forets bois
3 - 4 - 5 - 6 - 8 mm

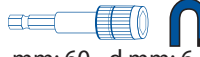
Adapt. Quick-Lock

L mm: 60 - d mm: 6,35
1 pc.

Cuter Metálico
Hoja Partible
Heavy Duty Metal Box Cutter
Couteaux métallique
à lames rétractables
1 pc.

Puntas Atornillar / Screwdriver Bits / Embouts vissage

PH d mm: 6,35
PH1
PH2
PH3
←25 mm→

d mm: 6,35
Tx
T10
T15
T20
T25
T27
T30
T40
←25 mm→

d mm: 6,35
SL
SL 4
SL 5,5
SL 6,5
←25 mm→

PZ d mm: 6,35
PZ1
PZ2
PZ3
←25 mm→

HEX d mm: 6,35
H3
H4
H5
←25 mm→

d mm: 6,35
Ts
TS15
TS20
TS25
TS30
TS40
←25 mm→

Nº	Art.	€
79873		66,52

CORONAS

Hole Saws

Trépan

Ref. **1645**

SIERRA CORONA METAL / MADERA

METAL / WOOD Hole Saw

Trépan MÉTAL / BOIS



HSSE 8% Co		INOX Stain- less	Bimetal	Aceros <850 N/mm ² Steel / Aciers	INOX Stainless Steel Acier INOX
TPI 4-6				Fundición Cast Iron Fonte	Cobre Copper Cuivre
				Madera Wood Bois	

D mm	L mm	P.G.	Pulgadas Inches / Pouces		Nº Art.	€	D mm	L mm	P.G.	Pulgadas Inches / Pouces		Nº Art.	€
14	37		9/16	1	20094	10,35	57	37		2 1/4	1	30325	17,76
16	37	9	5/8	1	20104	10,35	59	37	48	2 5/16	1	30326	17,76
17	37		11/16	1	21321	10,35	60	37		2 3/8	1	30328	17,76
19	37	11	3/4	1	30250	10,35	63	37		2 31/64	1	18801	19,37
20	37		25/32	1	30258	10,35	64	37		2 1/2	1	30329	19,37
21	37	14	13/16	1	30260	10,35	65	37		2 9/16	1	30331	19,37
22	37	16	7/8	1	30265	10,35	67	37		2 5/8	1	30388	19,37
23	37		14/16	1	30268	10,35	68	37		2 11/16	1	30391	19,37
24	37		15/16	1	30274	10,35	70	37		2 3/4	1	30392	19,37
25	37		1	1	30282	10,86	73	37		2 7/8	1	30393	19,37
27	37		1 1/16	1	30287	11,48	76	37		3	1	30394	19,84
29	37	21	1 1/8	1	30289	11,48	79	37		3 1/8	1	30395	19,85
30	37		1 3/16	1	30293	11,48	83	37		3 1/4	1	30396	19,85
32	37		1 1/4	1	30297	11,48	86	37		3 3/8	1	30397	19,85
33	37		1 5/16	1	30301	11,48	89	37		3 1/2	1	30398	19,85
35	37		1 3/8	1	30302	12,22	92	37		3 5/8	1	30399	23,03
37	37	29	1 7/16	1	30304	12,22	95	37		3 3/4	1	30400	27,01
38	37		1 1/2	1	30307	12,22	98	37		3 7/8	1	30401	28,92
40	37		1 9/16	1	30308	12,24	102	37		4	1	30402	30,22
41	37		1 5/8	1	30310	12,24	105	37		4 1/8	1	52485	33,63
43	37		1 11/16	1	30313	12,24	114	37		4 1/2	1	30403	56,48
44	37		1 3/4	1	30315	15,07	121	37		4 3/4	1	30404	62,94
46	37		1 13/16	1	30316	15,07	127	37		5	1	30405	66,84
48	37	36	1 7/8	1	30318	15,07	140	37		5 1/2	1	30406	71,47
50	37		1 31/32	1	18800	15,07	152	37		6	1	30407	74,10
51	37		2	1	30320	15,07	160	37		6 5/16	1	24475	145,73
52	37		2 1/16	1	30321	17,73	210	37		8 9/32	1	24606	172,41
54	37	42	2 1/8	1	30323	17,73							

Husillos y Adaptadores: Pag. 255 / Spindles & Adaptors: Pag. 255 / Arbres et Adaptateurs: Pag. 255



Línea 1m 1645

SIERRA CORONA METAL / MADERA

METAL / WOOD Hole Saw

Trépan MÉTAL / BOIS



∅	16	19	20	22	24	25	27	29	30	32	35	51	64	65	H3A	H4A
Pcs	2	2	2	2	2	2	2	2	2	2	2	2	2	2	2	2

Ref. 4995 - N° Art. 71040: 412,09 €

Display 19

SIERRA CORONA METAL / MADERA

METAL / WOOD Hole Saw

Trépan MÉTAL / BOIS



∅	16	19	20	22	24	25	27	29	30	32	35
Pcs	2	2	2	2	2	2	2	2	2	2	2
Ref. 1645	∅	38	40	41	43	44	48	51	54		
	Pcs	2	2	2	2	2	2	2	2	2	
Pcs	∅	60	65	68	70	76	79				
		2	2	2	2	2	2				
Ref. 1645 1646	∅	83	89	102	H3A	H4A	BR 90	BR 110			
	Pcs	1	1	1	3	3	3	3			

Ref. 4995 - N° Art. 22220: 881,59 €

Sets 1645

SIERRA CORONA METAL / MADERA

METAL / WOOD Hole Saw
Trépan MÉTAL / BOIS

Mod. 1
7 Pcs

Básico
Basic
Essentiel



Cont. Ø mm	Nº Art.	€
25-35-43-51-64-H3A-H4A	18232	101,23

Mod. 2
14 Pcs

Completo
Complete
Complet



Cont. Ø mm	Nº Art.	€
19-22-25-32-35-38-43-51-57-60-64-76-H3A-H4A	18234	201,01

Mod. 3
12 Pcs

Electricista
Electrician
Electricien



Cont. Ø mm	Nº Art.	€
16-20-25-32-40-43-51-60-63-65-H3A-H4A	18235	170,57

Mod. 4
8 Pcs

Básico 2
Basic 2
Essentiel 2



Cont. Ø mm	Nº Art.	€
16-20-25-32-40-51-H3A-H4A	58617	101,81

Mod. 5
11 Pcs

Electricista 2
Electrician 2
Electricien 2



Cont. Ø mm	Nº Art.	€
16-20-27-32-40-43-48-51-64-H3A-H4A	58618	149,12

Mod. 6
8 Pcs

Electricista 3
Electrician 3
Electricien 3



Cont. Ø mm	Nº Art.	€
22-35-51-57-68-76-H3A-H4A	66889	126,08

Ref. **1647**

CORONA MULTIPRO

MULTIPRO Hole Saw
Trépan MULTIPRO



Diente MD Carbide Tipped Dent Carbure	Meta-crilato
Fibra Vidrio Fiberglass Fibre de verre	DM MDF

Aceros Steel Aciers	Plásticos Plastics Plastiques	Madera Wood Bois	Ladrillo Brick Brique	Cerámica Ceramics Céramique
----------------------------------	--	-------------------------------	------------------------------------	--

D mm	L mm	Pulgadas Inches / Pouces	Z	N° Art.	€	
16	57	5/8	1	1	31855	10,26
19	57	3/4	1	1	30691	10,26
20	57	25/32	1	1	30692	10,26
22	57	7/8	1	1	30693	10,26
24	57	15/16	1	1	31856	10,78
25	57	1	1	1	30694	10,78
27	57	1 1/16	1	1	30695	11,40
29	57	1 1/8	1	1	30696	11,40
30	57	1 3/16	1	1	30697	11,40
32	57	1 1/4	1	1	30698	11,40
35	57	1 3/8	1	1	30699	12,15
38	57	1 1/2	1	1	30700	12,15
40	57	1 9/16	2	1	30701	12,15
41	57	1 5/8	2	1	30702	12,15
43	57	1 11/16	2	1	31857	14,94
44	57	1 3/4	2	1	30703	14,94
48	57	1 7/8	2	1	30704	14,94
51	57	2	2	1	30705	14,94
54	57	2 1/8	2	1	30706	17,57
57	57	2 1/4	2	1	30707	17,61
60	57	2 3/8	3	1	30708	17,61
64	57	2 1/2	3	1	30709	18,30

D mm	L mm	Pulgadas Inches / Pouces	Z	N° Art.	€	
65	57	2 3/16	3	1	30710	19,23
67	57	2 5/8	3	1	30711	19,23
68	57	2 11/16	3	1	30712	19,23
70	57	2 3/4	3	1	30713	19,23
73	57	2 7/8	3	1	30714	19,23
76	57	3	4	1	30715	19,67
79	57	3 1/8	4	1	30716	19,68
83	57	3 1/4	4	1	30717	19,68
86	57	3 3/8	4	1	30718	19,68
89	57	3 1/2	4	1	30719	19,68
92	57	3 5/8	4	1	30720	22,84
95	57	3 3/4	4	1	30721	26,78
98	57	3 7/8	4	1	30722	28,68
102	57	4	5	1	30723	29,97
105	57	4 1/8	5	1	30724	32,06
108	57	4 1/4	5	1	30725	34,29
111	57	4 3/8	5	1	30726	36,71
114	57	4 1/2	5	1	30727	55,98
121	57	4 3/4	5	1	30728	62,41
127	57	5	5	1	30729	66,27
140	57	5 1/2	5	1	30730	70,86
152	57	6	5	1	30731	73,47
160	57	6 5/16	5	1	30732	96,34

Husillos y Adaptadores: Pag. 255 / Spindles & Adaptors: Pag. 255 / Arbres et Adaptateurs: Pag. 255

Línea 1m 1647

CORONA MULTIPRO

MULTIPRO Hole Saw
Trépan MULTIPRO

30
cm



∅	25	29	30	35	40	51	60	67	68	73	76	H3C	H4C	BRC 110
Pcs	2	2	2	2	1	1	1	1	1	1	1	3	3	3

Ref. 4995 - N° Art. 72151: 318,74 €

Display 60

CORONA MULTIPRO

MULTIPRO Hole Saw
Trépan MULTIPRO



Ref. 1647	∅	16	19	20	22	24	25	27	29	30	32	35
	Pcs	2	2	2	2	2	2	2	2	2	2	2
Ref. 1647 1646	∅	38	40	41	43	44	48	51	54			
	Pcs	2	2	2	1	1	1	1	1			
Ref. 1647 1646	∅	60	65	68	70	76	79					
	Pcs	1	1	1	1	1	1					
Ref. 1647 1646	∅	83	89	102	H3C	H4C	BRC 110	BRC 110				
	Pcs	1	1	1	3	3	3	3				

Ref. 4995 - N° Art. 32965: 691,01 €



Ref. **1661**

SIERRA CORONA DIENTE MD INTEGRAL

Carbide Teeth Core Drill
Trépan denture carbure

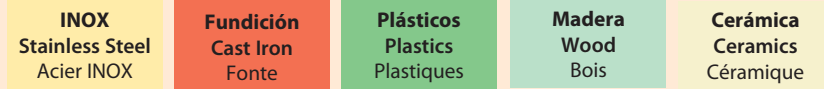
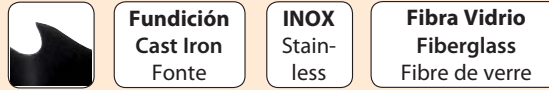

D mm	L mm	Pulgadas Inches / Pouces		Nº Art.	€
19	31	3/4	1	34311	20,60
22	31	7/8	1	34312	22,04
29	31	1 1/8	1	34314	25,87
32	31	1 1/4	1	34315	27,17
38	31	1 1/2	1	34317	32,11
44	31	1 3/4	1	34318	33,94
48	31	1 7/8	1	34319	37,10
51	31	2	1	34320	39,13
54	31	2 1/8	1	34321	40,10
57	31	2 1/4	1	34322	41,11
60	31	2 3/8	1	34323	43,10
64	31	2 1/2	1	34324	45,08
67	31	2 5/8	1	36831	47,34
76	31	3	1	34326	50,58
83	31	3 1/4	1	34327	54,14
86	31	3 3/8	1	34328	56,89
89	31	3 1/2	1	34329	59,64
95	31	3 3/4	1	34330	69,18
102	31	4	1	34331	73,21

Husillos y Adaptadores: Pag. 255 / Spindles & Adaptors: Pag. 255 / Arbres et Adaptateurs: Pag. 255

Ref. **1662**

CORONA POLVO MD ELECTRODEPOSITADO

Electrodeposited Carbide Powder Core Drill Bit
Trépan Poudre carbure électrodéposé



Polvo MD
Carbide Powder
Poudre Carbure



Kevlar



Fibra Vidrio
Fiberglass
Fibre de verre

Vidrio
Glass
Verre

Ladrillo
Brick
Brique

Cerámica
Ceramics
Céramique

D mm	L mm	Pulgadas Inches / Pouces		Nº Art.	€
16	36	5/8	1	34289	13,38
19	36	3/4	1	34290	14,62
20	36	25/32	1	34291	15,47
22	36	7/8	1	34292	16,19
25	36	1	1	34293	15,42
29	36	1 1/8	1	34294	16,73
32	36	1 1/4	1	34295	16,87
35	36	1 3/8	1	34296	17,41
38	36	1 1/2	1	34297	18,92
44	36	1 3/4	1	34298	18,98
48	36	1 7/8	1	34299	20,41
51	36	2	1	34300	20,82
54	36	2 1/8	1	34301	20,28
57	36	2 1/4	1	34302	22,22
60	36	2 3/8	1	34303	22,87
64	36	2 1/2	1	34304	23,38
70	36	2 3/4	1	34305	26,78
76	36	3	1	34306	29,64
83	36	3 1/4	1	34307	30,20
86	36	3 3/8	1	34308	32,65
95	36	3 3/4	1	34309	34,58
102	36	4	1	34310	37,83

Husillos y Adaptadores: Pag. 255 / Spindles & Adaptors: Pag. 255 / Arbres et Adaptateurs: Pag. 255



Ref. **1646**

HUSILLOS Y BROCCAS CORONAS

Hole Saw Spindles & Drill Bits
Arbres et forets trépan



HSS

Mod.	d mm	Corona Hole Saw Trépan mm		Nº Art.	€
H3A	9,52	14-30	1	19602	11,55
H4A	9,52	32-210	1	19603	19,90

MD/HM
TCT

Mod.	d mm	Corona Hole Saw Trépan mm		Nº Art.	€
H3C	9,52	14-30	1	39848	11,55
H4C	9,52	32-210	1	39849	19,90

MD/HM
TCT

Mod.	d mm	Corona Hole Saw Trépan mm		Nº Art.	€
New! H3S	SDS plus	14-30	1	13724	15,40
New! H4S	SDS plus	32-210	1	13725	30,62

Mod.	D mm	L mm		Nº Art.	€
BR 90	6,35	90	1	19605	3,32
BR 110	6,35	110	1	30019	3,63
BRC 110	7,00	110	1	39850	3,63

Ref. **1642**

ALARGADOR

Extension
Rallonge



Cap. mm	d mm	L mm		Nº Art.	€
9,52	11,00	300	1	69878	18,87



ELECCIÓN HUSILLOS Y BROCAS CORONAS

Hole Saw Spindles & Drill Bits Choice

Choix des arbres et forets trépan



INOX
Stain-
less



H3A



H4A



* BR 90 / BR 110

H3C



H4C



H3S



H4S



* BRC 110

* BR 110



Ref. 1647



Ref. 1645



Ref. 1661



Ref. 1662



Ceramic



Ref. **1860**

CORONA DIAMANTE HORMIGÓN

CONCRETE Diamond Core Bit

Trépan diamant BÉTON



Hormigón Reforzado
Reinforced Concrete
Béton armé

Hormigón
Concrete
Béton

Hormigón Bloque
Concrete Block
Parpaing



D mm	Rosca Thread Filet	L mm	Nº Segmentos	Alto Height Haut Segmento mm	Largo Length Longueur Segmento mm	Ancho Width Largeur Segmento mm	Kw*		Nº Art.	€
32	1" 1/4	300	3	9	24	4	0,7>1,2	1	34333	116,60
42	1" 1/4	300	4	9	24	4	0,7>1,2	1	34334	127,21
52	1" 1/4	450	5	9	24	4	0,7>1,2	1	34335	137,82
62	1" 1/4	450	6	9	24	4	0,7>1,2	1	34336	159,03
72	1" 1/4	450	6	9	24	4	0,7>1,2	1	34337	190,85
82	1" 1/4	450	7	9	24	4	1,2>2,3	1	34338	201,46
92	1" 1/4	450	8	9	24	4	1,2>2,3	1	34339	233,25
102	1" 1/4	450	9	9	24	4	1,2>2,3	1	34340	254,48
112	1" 1/4	450	9	9	24	4	1,2>2,3	1	34341	265,08
122	1" 1/4	450	10	9	24	4	1,2>2,3	1	34342	286,29
127	1" 1/4	450	11	9	24	4	1,2>2,3	1	34332	302,14
132	1" 1/4	450	11	9	24	5	1,2>2,3	1	34343	318,11
142	1" 1/4	450	12	9	24	5	1,2>2,3	1	34344	371,13
152	1" 1/4	450	12	9	24	5	1,2>2,3	1	34357	371,13
162	1" 1/4	450	12	9	24	5	2,3>3,9	1	34345	392,35
172	1" 1/4	450	13	9	24	5	2,3>3,9	1	34346	445,37
182	1" 1/4	450	13	9	24	5	2,3>3,9	1	34347	455,97
200	1" 1/4	450	15	9	24	5	2,3>3,9	1	34349	509,01
225	1" 1/4	450	15	9	24	5	2,3>3,9	1	34350	604,45
250	1" 1/4	450	16	9	24	5	2,3>3,9	1	34351	668,08
300	1" 1/4	450	17	9	24	5	2,3>3,9	1	34352	848,37

*Aplicar esta potencia y usar mucha agua para un rendimiento óptimo de la corona

*Use this power and plenty of water for an optimum performance of the core bit

*Appliquez cette puissance et utilisez de l'eau pour rendement optimale des trépan

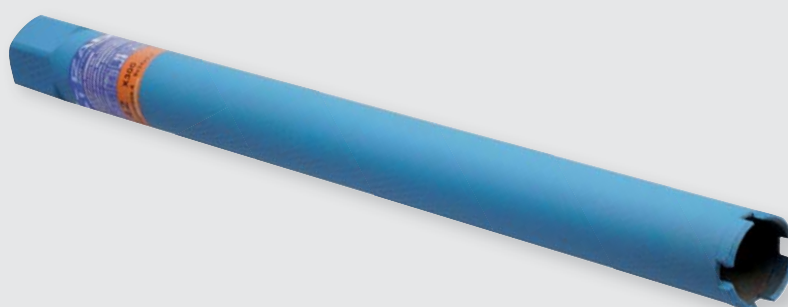

DISCOS DIAMANTE

Diamond Cutting Blades

Disques diamant

CUADRO USO DISCOS DIAMANTE

Diamond Disc Use Table

Tableau utilisation disques diamant

		Ref. 1851	Ref. 1852	Ref. 1853	Ref. 1854	Ref. 1855	Ref. 1857	Ref. 1858	Ref. 1861	Ref. 1862	Ref. 1863	Ref. 1864
<ul style="list-style-type: none"> ● Ideal - Ideal - Idéal ◐ Adecuado - Suitable - Convenable ○ Posible - Possible 												
	Hormigón Reforzado Reinforced Concrete Béton armé				●							
	Hormigón Seco Dry Concrete Béton sec	○	◐		●			◐				
	Hormigón Duro Hard Concrete Béton dur		○		●			◐				
	Hormigón Blando Soft Concrete Béton tendre	○	◐			◐						
	Hormigón Universal Universal Concrete Béton universel	◐	●		●		●	●	◐			
	Hormigón Silex Flint Concrete Béton silex						◐		○			
	Ladrillo Brick Brique	○	◐									
	Granito Duro Hard Granite Granite dur			◐	◐					●	◐	●
	Granito Medio Medium Granite Granite moyen		○					○			●	
	Granito Blando Soft Granite Granite tendre	○	◐					◐				
	Mármol Marble Marbre									●		
	Piedra Natural / Dura Natural / Hard Stone Pierre naturelle / Dure				○					○	○	
	Asfalto, Abrasivos Asphalt, Abrasives Asphalte, Abrasifs					●						
	Porcelánico, Gres, Azulejo Duro Porcelain, Stoneware, Hard Tile Porcelaine, Céramique, Carreau dur			●								

Ref. **1851**

SEGMENTADO RÁPIDO OBRA GENERAL

General Works **Fast** Segmented
Segmenté **rapide** général travaux



Hormigón Universal
Universal Concrete
Béton universel

Hormigón Seco
Dry Concrete
Béton sec

Hormigón Blando
Soft Concrete
Béton tendre

Granito Blando
Soft Granite
Granite tendre

Ladrillo
Brick
Brique

D mm	d1 mm	Nº Segmentos	Alto Height Segmento mm	Ancho Width Largeur Segmento mm	Grosor Acero Steel Thickness Épaisseur acier mm	Max R.P.M.		Nº Art.	€
115	22,23	8	12	2,40	1,4	13300	1	60720	7,45
125	22,23	9	12	2,40	1,4	12250	1	60722	8,86
180	22,23	14	12	2,60	1,6	8500	1	67886	17,91
230	22,23	16	12	2,80	1,8	6650	1	60723	22,59
300	25,40	22	12	3,20	2,2	6400	1	60724	43,99
350	25,40	24	12	3,20	2,2	5500	1	60725	54,46

Ref. **1852**

SEGMENTADO LÁSER PROFESIONAL ALTO RENDIMIENTO

Long Life Professional Segmented Laser
Professionnel segmenté laser **haut rendement**



Hormigón Universal
Universal Concrete
Béton universel

Hormigón Seco
Dry Concrete
Béton sec

Hormigón Duro
Hard Concrete
Béton dur

Granito Medio
Medium Granite
Granite moyen

Granito Blando
Soft Granite
Granite tendre

Ladrillo
Brick
Brique

D mm	d1 mm	Nº Segmentos	Alto Height Segmento mm	Ancho Width Largeur Segmento mm	Grosor Acero Steel Thickness Épaisseur acier mm	Max R.P.M.		Nº Art.	€
115	22,23	9	10	2,20	1,4	13300	1	64078	21,65
125	22,23	10	10	2,20	1,4	12250	1	60729	28,34
150	22,23	12	10	2,20	1,4	10200	1	60730	34,20
180	22,23	14	10	2,40	1,6	8500	1	68880	39,03
230	22,23	16	10	2,60	1,8	6650	1	60731	49,42
300	20,00	20	10	3,00	2,2	6400	1	68883	66,66
350	20,00	20	10	3,20	2,4	5500	1	68889	79,75
350	25,40	23	10	3,20	2,4	5500	1	68890	79,75

Ref. **1858**

TURBO OBRA GENERAL

General Works Turbo
Général travaux turbo



Hormigón Universal
Universal Concrete
Béton universel

Hormigón Seco
Dry Concrete
Béton sec

Hormigón Duro
Hard Concrete
Béton dur

Granito Medio
Medium Granite
Granite moyen

Granito Blando
Soft Granite
Granite tendre

D mm	d1 mm	Nº Segmentos	Alto Height Haut Segmento mm	Ancho Width Largeur Segmento mm	Grosor Acero Steel Thickness Épaisseur acier mm	Max R.P.M.		Nº Art.	€
115	22,23	9	10	2,20	1,4	13300	1	64080	19,38
125	22,23	10	10	2,20	1,4	12250	1	60726	24,50
150	22,23	12	10	2,20	1,4	10200	1	60727	29,09
180	22,23	14	10	2,40	1,6	8500	1	69565	39,03
230	22,23	16	10	2,60	1,8	6650	1	60728	60,19

Ref. **1854**

SOLDADO LASER FORMA N

N Form Laser Welded
Soudé laser forme N



Hormigón Reforzado
Reinforced Concrete
Béton armé

Hormigón Seco
Dry Concrete
Béton sec

Hormigón Duro
Hard Concrete
Béton dur

Hormigón Universal
Universal Concrete
Béton universel

Granito Duro
Hard Granite
Granite dur

Piedra Natural
Natural Stone
Pierre naturelle

D mm	d1 mm	Nº Segmentos	Alto Height Haut Segmento mm	Ancho Width Largeur Segmento mm	Grosor Acero Steel Thickness Épaisseur acier mm	Max R.P.M.		Nº Art.	€
125	22,23	10	10	2,20	1,4	12250	1	60740	31,48
180	22,23	14	10	2,40	1,6	8500	1	68895	50,20
230	22,23	15	10	2,60	1,8	6650	1	60741	55,67
300	25,40	20	10	3,00	2,2	6400	1	60742	105,60
350	25,40	23	10	3,00	2,2	5500	1	60743	131,34

Ref. **1853**

TURBO PORCELÁNICO

PORCELAIN Turbo
Turbo PORCELAINE



Porcelain

Porcelánico, Gres, Azulejo Duro
Porcelain, Stoneware, Hard Tile
Porcelaine, Céramique, Carreau dur

Granito Duro
Hard Granite
Granite dur

D mm	d1 mm	Nº Segmentos	Alto Height Haut Segmento mm	Ancho Width Largeur Segmento mm	Grosor Acero Steel Thickness Épaisseur acier mm	Max R.P.M.		Nº Art.	€
115	22,23	Continuo	11	1,30	1,0	13300	1	60732	25,91
125	22,23	Continuo	11	1,30	1,0	12250	1	60739	28,48
230	22,23	Continuo	11	1,50	1,2	6650	1	66552	61,68

Ref. **1855**

SOLDADO LASER ASFALTO

ASPHALT Laser Welded
Soudé Laser ASPHALTE



Abrasivos

Asfalto, Abrasivos
Asphalt, Abrasives
Asphalte, Abrasifs

Hormigón Blando
Soft Concrete
Béton tendre

Gran protección del segmento para evitar el corte inferior
No undercutting by strong wedge protection
Forte protection du ségment pour éviter la coupe inférieure.

D mm	d1 mm	Nº Segmentos	Alto Height Haut Segmento mm	Ancho Width Largeur Segmento mm	Grosor Acero Steel Thickness Épaisseur acier mm	Max R.P.M.		Nº Art.	€
300	25,40	18	10	3,20	2,2	6400	1	60744	75,57
350	25,40	21	10	3,20	2,2	5500	1	60745	97,03
400	25,40	24	10	3,40	2,4	4800	1	60747	123,35

Ref. **1861**

HORMIGÓN FORMA DOBLE COPA

Double Rowed Cup Form Concrete
Béton forme double coupe



Hormigón Universal
Universal Concrete
Béton universel

Hormigón Silex
Flint Concrete
Béton Silex

D mm	d1 mm	Nº Segmentos	Alto Height Haut Segmento mm	Ancho Width Largeur Segmento mm	Grosor Acero Steel Thickness Épaisseur acier mm	Max R.P.M.		Nº Art.	€
115	22,23	12	8	5,00	3,0	13300	1	69473	46,40
125	22,23	14	8	5,00	3,0	12250	1	69475	50,63
180	22,23	28	8	5,00	3,0	8500	1	69477	97,04

Ref. **1857**

TOP HORMIGÓN FORMA COPA Y ALTO RENDIMIENTO

Long Life Y Cup Form Concrete
Top béton forme coupe Y haut rendement



Hormigón Universal
Universal Concrete
Béton universel

Hormigón Silex
Flint Concrete
Béton Silex

Segmentos auto-afilados, superficie fina, tolerancia precisa, eficiente extracción del polvo
Self-sharpened segments, smooth surface, accurate tolerance, efficient dust exhausting
Ségments auto-affûtés, Surface fine, tolerance précise, extraction efficace de la poussière

D mm	d1 mm	Nº Segmentos	Grosor Acero Steel Thickness Épaisseur acier mm	Max R.P.M.		Nº Art.	€
115	22,23	8	3,0	13300	1	60749	56,24
125	22,23	8	3,0	12250	1	60750	63,77
180	22,23	12	3,0	8500	1	64082	125,23

Ref. **1864**

GRANITO FORMA COPA "Y" DE ALUMINIO

Aluminium Cup Wheel for **Granite**
Granite forme coupe "Y" aluminium

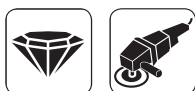

Granito Duro
Hard Granite
Granite Dur

Cuerpo de aluminio, filo amolado fino
Aluminium body, smooth edge grinding
Corps en aluminium, filet meulé fin

D mm	d1 mm	Alto Height Haut Segmento mm	Ancho Width Largeur Segmento mm	Grosor Acero Steel Thickness Épaisseur acier mm	Max R.P.M.		Nº Art.	€
100	22,23	20	7,30	5,5	14500	1	69487	67,50

Ref. **1862**

TURBO GRANITO / MÁRMOL

Turbo Granite / **Marble**
Turbo granite / **marbre**

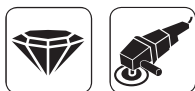

Granito Duro
Hard Granite
Granite dur

Mármol
Marble
Marbre

Piedra Dura
Hard Stone
Pierre dure

Forma en ola, no descascarilla el material
Wave shape, no wobbling during cutting
Forme vaguee, matériel sans décortilage

D mm	d1 mm	Alto Height Haut Segmento mm	Ancho Width Largeur Segmento mm	Grosor Acero Steel Thickness Épaisseur acier mm	Max R.P.M.		Nº Art.	€
115	22,23	7	2,20	1,2	13300	1	69479	26,58
230	22,23	8	2,60	1,8	6650	1	69481	67,50

Ref. **1863**

LASER CANTERO

Laser Quarry
Laser carrière

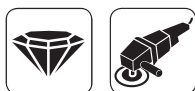

Granito Duro
Hard Granite
Granite dur

Granito Medio
Medium Granite
Granite moyen

Piedra Dura
Hard Stone
Pierre dure

Corte estable y gran rendimiento
Stable cutting high performance
Coupe stable et haute performance

D mm	d1 mm	Nº Segmentos	Alto Height Haut Segmento mm	Ancho Width Largeur Segmento mm	Grosor Acero Steel Thickness Épaisseur acier mm	Max R.P.M.		Nº Art.	€
230	22,23	15	12	3,20	2,2	6650	1	69485	84,38

Ref. **1849**

AMARRE RÁPIDO AMOLADORA

Quick Lock Grinding Tool
Attachement rapide meuleuse



Mod.	Nº Art.	€
1	55946	22,52

Ref. **8309**

CUTER HOJA PARTIBLE 9 MM

9 mm Snap-Off Blade Box Cutter
Couteau à lames rétractables 9 mm



MOD. 9

Zamak
5



Mod.	Hoja Blade / Lame mm		Nº Art.	€
9	9	1	34238	9,74

Cúter con cuerpo metálico con mecanismo de bloqueo y almacén para cuchillas de repuesto. Incluye 3 cuchillas.

Box Cutter with metal body, locking mechanism and storage for spare blades. Includes 3 blades.

Couteau à lames avec corps en métal, mécanisme de verrouillage et dépôt pour les lames de rechange. Comprend 3 lames.

Ref. **8318**

CUTER HOJA PARTIBLE 18 MM

18 mm Snap-Off Blade Box Cutter
Couteau à lames rétractables 18 mm



New!

MOD. 18-ERG



Mod.	Hoja Blade / Lame mm		Nº Art.	€
18-ERG	18	1	83359	3,87

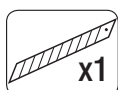

- Cuchilla de 15 Segmentos
- 15 segment blade
- Lame à 15 segments

**ABS
Soft**

- Ergonómico. ABS para mejor agarre
- Ergonomic. ABS for better grip
- Ergonomique. ABS pour une meilleure prise

**INOX
Stainless**

- Portacuchillas inoxidable
- Stainless blade holder
- Porte-lames inoxydable



**Box-Pallet
8320**

24 uds

Nº
Art. €
10177 **88,24**

MOD. 18

Zamak
5



Mod.	Hoja Blade / Lame mm		Nº Art.	€
18	18	1	34239	16,01

Cúter con cuerpo metálico con mecanismo de bloqueo y almacén para cuchillas de repuesto. Incluye 3 cuchillas.

Box Cutter with metal body, locking mechanism and storage for spare blades. Includes 3 blades.

Couteau à lames avec corps en métal, mécanisme de verrouillage et dépôt pour les lames de rechange. Comprend 3 lames.

Ref. **8319**

CUTER HOJA SEGURIDAD 19 MM

19 mm Security Blade Box Cutter
Couteau à lame sécurité 19 mm



New! MOD. 19S-RET



Mod.	Hoja Blade / Lame mm		Nº Art.	€
19S-RET	59x19x0,61	1	83360	9,40

- Recogida semiautomática de la cuchilla después del corte, evitando lesiones.
- After cutting, semi-automatic Blade collection, avoiding injuries.
- Ramassage semi-automatique de la lame après la coupe, pour éviter des blessures
- Mango ergonómico
- Ergonomic handle
- Poignée ergonomique
- Cambio de cuchilla rápido y sencillo. Incluye 3 cuchillas
- Quick Blade change. Includes 3 blades.
- Changement de lame rapide et facile. Comprend 3 lames.



Box-Pallet
8320
6 uds

Nº Art.	€
10174	53,58

MOD. 19S



Zamak
5

Mod.	Hoja Blade / Lame mm		Nº Art.	€
19S	60x19x0,65	1	34240	6,37

Cúter metálico con almacén para
cuchillas de repuesto.

Metal Box Cutter with storage for spare
blades.

Couteau à lames en métal avec dépôt pour
les lames de rechange.



Ref. 8309

Ref. 8318

Ref. 8319

	Mod.	Hoja Blade / Lame mm		Nº Art.	€ 1 ud.
	9	9	10	34241	0,29
(New!)	18-ERG	18	10	83765	0,40
	18	18	10	34242	0,42
(New!)	19S-RET-TRA	59x19x0,61	10	83766	0,33
(New!)	19S-RET-GAN	Gancho / Hook / Crochet	10	83767	0,37
	19S	60x19x0,65	10	34243	0,35



MADERA

Wood
Bois

BROCAS

Drill Bits
Forets

268

FRESAS

Router Cutters
Fraises

285



BROCAS

Drill Bits

Forets

Ref. **1641**

BROCA PUNTA CENTRAR PRO

PRO Drill Bit
Foret auto-centreur PRO



- | | | |
|-------------------------------|------------------------|-----------------------------------|
| - Óptima evacuación de viruta | - Optimum chipping-off | - Evacuation optimale des copeaux |
| - Más rápida | - Faster | - Plus rapide |
| - Mejor centrado | - Better centering | - Meilleur auto-centrage |
| - Mayor durabilidad | - Longer tool life | - Vie plus longue de l'outil |
| - Mayor precisión | - Higher precision | - Meilleure precision |
| - Agujeros limpios | - Clean holes | - Trous plus propres |



Maderas Duras
Hard Wood
Bois dur

Maderas Tropicales
Tropical Wood
Bois Tropical

Contrachapado
Plywood
Contreplaqué

D mm	L mm	l mm	d mm		Nº Art.	€
3	61	33	3	1	34450	1,84
4	75	43	4	1	34451	2,21
5	86	52	5	1	34452	2,72
6	93	57	6	1	34453	3,14
8	117	75	8	1	34454	4,93
10	133	87	10	1	34455	7,01

Línea 33 cm
1641

BROCA PUNTA CENTRAR PRO

PRO Drill Bit
Foret auto-centreur PRO



ø	3	4	5	6	8	10
Pcs	5	5	5	5	5	5

Ref. 4995 - Nº Art. 71044: 109,25 €



Display 52 Mixto PRO



BROCAS MULTI INOX + PARED PRO + MADERA PRO

Multi-Stainless + Concrete Pro + Wood Pro Drill Bits

Forets Multi INOX + Béton Pro + Bois Pro

Ref. 1886	∅	3	4	5	6	7	8	9	10	12	14
	Pcs	5	5	10	10	5	5	3	3	3	3
Ref. 1641	∅	3	3	4	4	5	5	6	6	8	10
	Pcs	3	2	3	2	3	2	3	2	5	5
Ref. 1004	∅	1	2	3	3,5	4	4,5	5	6	8	10
	Pcs	2	2	3	3	5	5	5	5	5	3

Ref. 4995 - N° Art. 68575: 463,36 €

Display 55



BROCAS MADERA PRO: PALA Y 3 PUNTAS

Wood Pro Drill Bits: Flat & Center Point

Forets Bois Pro: plate et auto-centreur

Ref. 1651	∅	22	24	25	26	28	30				
	Pcs	5	5	5	5	5	5				
Ref. 1651	∅	10	12	14	16	18	20				
	Pcs	5	5	5	5	5	5				
Ref. 1641	∅	3	3	4	4	5	5	6	6	8	10
	Pcs	5	5	5	5	5	5	5	5	5	5

Ref. 4995 - N° Art. 70074: 405,97 €

Display 58



BROCAS MADERA PRO 3 PUNTAS

Center Point Wood Pro Drill Bits

Forets Bois Pro auto-centreur

Ref. 1641	∅	3	3	4	4	5	5	6	6	8	10
	Pcs	5	5	5	5	5	5	5	5	5	5

Ref. 4995 - N° Art. 70088: 218,50 €

Ref. **1640**

BROCA PUNTA CENTRAR

Center Point Drill Bit
Foret auto-centreur



CrV

Maderas Blandas
Soft Wood
Bois tendre

D mm	L mm	l mm	d mm		Nº Art.	€
3	61	33	3,00	1	18426	0,64
4	75	43	4,00	1	18427	0,65
5	86	52	5,00	1	18429	0,69
6	97	60	6,00	1	18430	0,87
7	109	69	7,00	1	18432	0,94
8	117	75	8,00	1	18433	1,19
9	125	80	9,00	1	18435	1,40
10	133	87	10,00	1	18436	1,47

D mm	L mm	l mm	d mm		Nº Art.	€
11	142	89	9,95	1	30380	1,85
12	151	96	9,95	1	18438	2,03
13	151	96	9,95	1	30381	2,13
14	151	97	9,95	1	18439	2,34
15	160	100	9,95	1	30382	2,74
16	160	100	9,95	1	30383	3,12
18	180	120	9,95	1	17860	7,93
20	200	130	9,95	1	17861	9,64

Larga / Long / Longue

D mm	L mm	l mm	d mm		Nº Art.	€
6	250	200	6,00	1	55969	2,25
8	250	200	8,00	1	55970	2,57
10	250	200	10,00	1	55971	3,34
12	250	200	9,95	1	55972	4,00



Línea 1m
1640

BROCA PUNTA CENTRAR

Center Point Drill Bit
Foret auto-centreur



ø	3	4	5	6	7	8	9	10	11	12	13	14	15	16	18	20
Pcs	10	10	10	10	10	10	5	5	5	5	5	5	5	3	3	3

Ref. 4995 - Nº Art. 71047: **181,67 €**



Display 10



BROCAS MADERA PALA Y 3 PUNTAS

Flat & Center Point Wood Drill Bits

Forets Bois mèches plates & 3-pointes

Ref. 1650 (L 152)	∅	22	24	25	26	28	30	32			
	Pcs	7	5	5	5	5	5	5	5		
Ref. 1650 (L 152)	∅	6	8	10	12	14	16	18	20		
	Pcs	7	7	7	7	7	7	7	7	7	
Ref. 1640	∅	3	4	5	6	8	9	10	12	14	16
	Pcs	10	10	10	10	10	5	5	5	5	5

Ref. 4995 - N° Art. 22184: 320,11 €

Display 51



BROCAS METAL + PARED + MADERA

Metal + Masonry + Wood Drill Bits

Forets Métal + Maçonnerie + Bois

Ref. 1880	∅	3	4	5	6	7	8	9	10	12	14
	Pcs	10	10	10	10	10	10	5	5	5	5
Ref. 1640	∅	3	4	5	6	8	9	10	12	14	16
	Pcs	10	10	10	10	10	5	5	5	5	5
Ref. 1001	∅	1	2	3	3,5	4	4,5	5	6	8	10
	Pcs	10	10	10	10	10	10	10	5	5	3

Ref. 4995 - N° Art. 68572: 333,01 €



Display 59



BROCAS SPEED POINT + PARED + MADERA

Speed Point + Masonry + Wood Drill Bits
Forets Speed Point + Maçonnerie + Bois

Ref. 1880	∅	3	4	5	6	7	8	9	10	12	14
	Pcs	10	10	10	10	10	10	5	5	5	5
Ref. 1640	∅	3	4	5	6	8	9	10	12	14	16
	Pcs	10	10	10	10	10	5	5	5	5	5
Ref. 1002	∅	2	3	3,5	4	4,5	5	6	7	8	10
	Pcs	10	10	10	10	10	10	5	5	5	3

Ref. 4995 - N° Art. 70099: 334,26 €

Display 23



JUEGOS CASSETTE MADERA Y CONSTRUCCIÓN

Wood & Construction Cassette Sets
Jeux cassette Bois & Construction

Constr. Madera Wood / Bois	Pcs	Ref. 1485 Pared Masonry / Béton 5 Pcs.	Ref. 1486 Pared Pro Masonry Pro / Béton Pro 5 Pcs.	Ref. 1435 Madera Wood / Bois 5 Pcs.	Ref. 1438 Madera Wood / Bois 8 Pcs.
		5	5	5	5
Constr.	Pcs	Ref. 1488 Pared Masonry / Béton 8 Pcs.	Ref. 1487 Pared Pro Masonry Pro / Béton Pro 8 Pcs.	Ref. 1494 SDS plus 4 Pcs.	
		5	5	3	

Ref. 4995 - N° Art. 22372: 395,50 €

Sets 1640

BROCA PUNTA CENTRAR

Center Point Drill Bit
Foret auto-centreur



Set **1435**

5 Pcs

Cont. Ø	Nº Art.	€
4-5-6-8-10 mm	30223	6,02

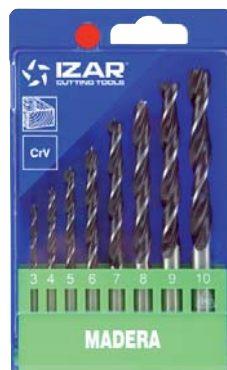

Set **1438**

8 Pcs

Cont. Ø	Nº Art.	€
3-4-5-6-7-8-9-10 mm	30226	9,05



Set **1460**

9 Pcs

Cont. Ø	Nº Art.	€
3 Pcs Metal: 5-6-8 3 Pcs Madera/Wood/Bois: 5-6-8 3 Pcs Pared/Masonry/Béton 5-6-8	55610	10,60

Línea 33 cm 14S1

SETS BROCAS METAL, PARED PRO, PARED, MADERA

Metal, Concrete, Masonry, Wood Sets
Jeux Métal, Béton, Maçonnerie, Bois



	Metal Metal Métal	Pared Pro Concrete Béton	Pared Masonry Maçonnerie	Madera Wood Bois
Ref	1462-1010	1486	1485	1435
Diam	2-3-4-5-6-8 mm	4-5-6-8-10 mm	4-5-6-8-10 mm	4-5-6-8-10 mm
Pcs.	5	5	5	5

Ref. 4995 - Nº Art. 72193: 170,80 €

Ref. **1651**

BROCA PLANA GRAN RENDIMIENTO

Heavy Duty Flat Bit
Mèche plate haut rendement



Maderas Blandas
Soft Wood
Bois tendre



D mm	d mm	L mm	l mm		Nº Art.	€
6,00	6,35	152	38	1	56019	2,53
8,00	6,35	152	38	1	56021	2,53
10,00	6,35	152	38	1	56022	2,67
12,00	6,35	152	42	1	56023	2,93
13,00	6,35	152	42	1	56024	2,93
14,00	6,35	152	42	1	56025	3,06
16,00	6,35	152	42	1	56026	3,06
18,00	6,35	152	42	1	56028	3,76
19,00	6,35	152	42	1	56029	3,76
20,00	6,35	152	42	1	56030	3,76
22,00	6,35	152	42	1	56031	3,76
24,00	6,35	152	46	1	56032	4,69
25,00	6,35	152	46	1	56033	4,69
26,00	6,35	152	46	1	56034	4,69
28,00	6,35	152	46	1	56035	6,02
30,00	6,35	152	46	1	56036	6,35
32,00	6,35	152	46	1	56037	6,35
35,00	6,35	152	46	1	56038	7,34
38,00	6,35	152	46	1	56040	8,32
40,00	6,35	152	46	1	56042	8,38



Ref. **1651**

8 Pcs

Cont. Ø	Nº Art.	€
12-16-18-20-22-25-28-32 mm	57449	34,31

Línea 1m
1651

BROCA PLANA GRAN RENDIMIENTO

Heavy Duty Flat Bit
Mèche plate haut rendement



43
cm



Ø	6	8	10	12	14	16	18	20	22	24	25	26	28	30	32	35	38	L305
Pcs	8	8	8	8	8	8	8	8	5	5	5	5	5	5	5	5	5	1

Ref. 4995 - Nº Art. 72169: 465,63 €

Ref. **1653**

ALARGADOR

Extension
Rallonge



L mm	d mm	D mm		Nº Art.	€
305	6,35	15,85	1	23982	10,28

Display 55



BROCAS MADERA PRO: PALA Y 3 PUNTAS

Wood Pro Drill Bits: Flat & Center Point

Forets Bois Pro: Plate et auto-centreur

Ref. 1651	∅	22	24	25	26	28	30				
	Pcs	5	5	5	5	5	5	5	5		
Ref. 1651	∅	10	12	14	16	18	20				
	Pcs	5	5	5	5	5	5	5	5		
Ref. 1641	∅	3	3	4	4	5	5	6	6	8	10
	Pcs	5	5	5	5	5	5	5	5	5	5

Ref. 4995 - N° Art. 70074: 405,97 €

Display 56



BROCAS MADERA PRO: PALA

Wood Pro Drill Bits: Flat

Forets Bois Pro: Plate

Ref. 1651	∅	10	12	14	16	18	20		
	Pcs	10	10	10	10	10	10	10	10

Ref. 4995 - N° Art. 70078: 192,36 €

Display 57



BROCAS MADERA PRO: PALA

Wood Pro Drill Bits: Flat

Forets Bois Pro: Plate

Ref. 1651	∅	22	24	25	26	28	30		
	Pcs	5	5	5	5	5	5	5	5

Ref. 4995 - N° Art. 70084: 150,98 €

Ref. **1650**

BROCA PLANA

Flat Bit
Mèche plate



Pala
Flat
Plate



Maderas Blandas
Soft Wood
Bois tendre

Larga / Long / Longue

D mm	L mm	l mm	d mm		Nº Art.	€
6	152	38	6,35	1	30384	1,53
8	152	38	6,35	1	30385	1,53
10	152	38	6,35	1	30386	1,61
12	152	42	6,35	1	30387	1,77
13	152	42	6,35	1	55988	1,82
14	152	42	6,35	1	18457	1,85
16	152	42	6,35	1	18459	2,03
17	152	42	6,35	1	55989	2,16
18	152	42	6,35	1	18460	2,28
19	152	42	6,35	1	55990	2,28
20	152	42	6,35	1	18462	2,28
22	152	42	6,35	1	18463	2,65
24	152	46	6,35	1	18465	2,84
25	152	46	6,35	1	18466	3,22
26	152	46	6,35	1	18468	3,38
28	152	46	6,35	1	18469	3,64
30	152	46	6,35	1	18471	3,84
32	152	46	6,35	1	18472	4,10
35	152	46	6,35	1	55992	4,60
36	152	46	6,35	1	30389	4,74
38	152	46	6,35	1	30390	5,05
40	152	46	6,35	1	17864	5,07

D mm	L mm	l mm	d mm		Nº Art.	€
6	400	38	6,35	1	55973	6,43
8	400	38	6,35	1	55974	6,43
10	400	38	6,35	1	55975	6,74
12	400	42	6,35	1	55976	7,45
14	400	42	6,35	1	55977	6,41
16	400	42	6,35	1	55978	7,04
18	400	42	6,35	1	55979	7,93
20	400	42	6,35	1	55980	7,93
22	400	42	6,35	1	55981	9,19
24	400	46	6,35	1	55982	9,85
25	400	46	6,35	1	55983	11,23
28	400	46	6,35	1	55984	12,64
30	400	46	6,35	1	55985	13,33
32	400	46	6,35	1	55986	14,32
35	400	46	6,35	1	55987	16,08



Doble Blister
ref. M650
pag. 380



Ref. **1650**

8 Pcs

Cont. Ø	Nº Art.	€
12-16-18-20-22- 25-28-32 mm	66378	21,98



Línea 1m
1650

BROCA PLANA

Flat Bit
Mèche plate



∅	6	8	10	12	14	16	18	20	22	24	25	26	28	30	32	36	38	L305
Pcs	10	10	10	10	10	10	10	10	5	5	5	5	5	5	5	5	5	1

Ref. 4995 - N° Art. 71051: **326,57 €**

Display
10

BROCAS MADERA PALA Y 3 PUNTAS

Flat & Center Point Wood Drill Bits
Forets Bois mèches plates & 3-pointes



Ref. 1650	∅	22	24	25	26	28	30	32			
(L 152)	Pcs	7	5	5	5	5	5	5			
Ref. 1650	∅	6	8	10	12	14	16	18	20		
(L 152)	Pcs	7	7	7	7	7	7	7	7		
Ref. 1640	∅	3	4	5	6	8	9	10	12	14	16
	Pcs	10	10	10	10	10	5	5	5	5	5

Ref. 4995 - N° Art. 22184: **320,11 €**



Ref. **1655**

BROCA ESPIRAL TORNILLO EN LA PUNTA

Screw-Point Auger Drill Bit

Foret spirale vis en pointe



CrV

Maderas Duras
Hard Wood
Bois dur



D mm	L mm	l mm	d mm		Nº Art.	€
6	230	155	5,5	1	19139	9,47
7	230	155	6,5	1	66809	9,74
8	230	155	7,5	1	19145	9,99
9	230	155	8,5	1	66811	10,28
10	230	155	9,5	1	19148	10,55
11	230	155	10,5	1	66812	10,77
12	230	155	11,5	1	19154	10,97
13	230	155	12,5	1	66813	11,29
14	230	155	12,5	1	19172	11,61
16	230	155	12,5	1	19187	13,31
18	230	155	12,5	1	19202	16,95
20	230	155	12,5	1	19211	19,25
22	230	155	12,5	1	19226	21,50
23	230	155	12,5	1	66814	22,54
24	230	155	12,5	1	19235	23,59
25	230	155	12,5	1	66815	24,66
26	230	155	12,5	1	27304	25,74
28	230	155	12,5	1	27604	30,38
30	230	155	12,5	1	27630	43,47
32	230	155	12,5	1	29040	43,47

D mm	L mm	l mm	d mm		Nº Art.	€
6	460	385	5,5	1	60683	11,38
8	460	385	7,5	1	19082	11,99
10	460	385	9,5	1	19151	13,06
12	460	385	11,5	1	19163	14,15
14	460	385	12,5	1	19181	17,32
16	460	385	12,5	1	19193	20,52
18	460	385	12,5	1	19205	27,46
20	460	385	12,5	1	19217	30,79
22	460	385	12,5	1	19229	33,87
24	460	385	12,5	1	19238	37,13
26	460	385	12,5	1	27603	40,33
28	460	385	12,5	1	27605	43,70
30	460	385	12,5	1	27680	47,94
32	460	385	12,5	1	29041	53,28

D mm	L mm	l mm	d mm		Nº Art.	€
8	600	530	7,5	1	67750	16,98
10	600	530	9,5	1	15811	19,89
12	600	530	11,5	1	15813	20,47
14	600	530	12,5	1	15816	29,07
16	600	530	12,5	1	15817	34,13
18	600	530	12,5	1	15823	51,42
20	600	530	12,5	1	15828	58,70
22	600	530	12,5	1	15855	65,66

Línea 1m
1655

BROCA ESPIRAL TORNILLO EN LA PUNTA

Screw-Point Auger Drill Bit

Foret spirale vis en pointe

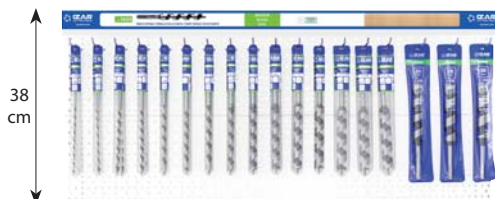

ø	6	7	8	9	10	11	12	13	14	16	18	20	22	23	24	25	26	28	30
Pcs	2	2	2	2	2	2	2	2	2	2	2	2	1	1	1	1	1	1	1

Ref. 4995 - Nº Art. 72171: 480,22 €

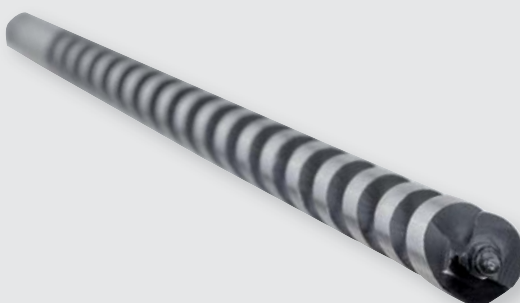

Display 11



BROCA ESPIRAL TORNILLO EN LA PUNTA

Screw-Point Auger Drill Bit

Foret spirale vis en pointe

∅	18 L460	20 L460	22 L460	24 L460	26 L460	28 L460	30 L460	32 L460
Pcs	2	2	1	1	1	1	1	1
∅	26 L230	28 L230	30 L230	32 L230	10 L460	12 L460	14 L460	16 L460
Pcs	1	1	1	1	2	2	2	2
∅	10 L230	12 L230	14 L230	16 L230	18 L230	20 L230	22 L230	24 L230
Pcs	2	2	2	2	2	2	1	1

Ref. 4995 - N° Art. 22307: 856,29 €

Display 38



39
cm

∅	10 L230	12 L230	14 L230	16 L230	18 L230	20 L230	22 L230	24 L230
Pcs	2	2	2	2	2	2	1	1

Ref. 4995 - N° Art. 22624: 210,37 €

Display 39



62
cm

∅	26 L230	28 L230	30 L230	32 L230	10 L460	12 L460	14 L460	16 L460
Pcs	1	1	1	1	2	2	2	2

Ref. 4995 - N° Art. 22626: 273,16 €

Display 40



62
cm

∅	18 L460	20 L460	22 L460	24 L460	26 L460	28 L460	30 L460	32 L460
Pcs	2	2	1	1	1	1	1	1

Ref. 4995 - N° Art. 22627: 372,76 €

Ref. **1644**

BROCA ENCOFRADO MADERA SDS PLUS

SDS PLUS WOOD Cavity Drill Bit
Foret coffrage BOIS SDS PLUS

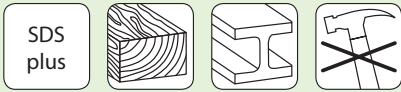

Aceros
Steel
Aciers

Madera
Wood
Bois

D mm	L mm	I mm		Nº Art.	€
10	400	87	1	15447	18,76
12	400	100	1	15450	20,20
14	400	100	1	15453	26,36
16	400	100	1	15460	33,29
18	400	100	1	15507	43,50
20	400	100	1	15576	48,07
22	400	100	1	15579	55,57
24	400	100	1	15582	70,76
26	400	100	1	15603	83,84
28	400	100	1	15621	90,07
30	400	100	1	15627	99,96

D mm	L mm	I mm		Nº Art.	€
10	600	87	1	15660	19,46
12	600	100	1	15669	21,71
14	600	100	1	15780	29,10
16	600	100	1	15781	36,00
18	600	100	1	15783	46,31
20	600	100	1	15784	50,84
22	600	100	1	15793	58,37
24	600	100	1	15799	73,52
26	600	100	1	15801	86,69
28	600	100	1	15807	92,85
30	600	100	1	15808	102,85

Línea 1m
1644

BROCA ENCOFRADO MADERA SDS PLUS L400

L400 SDS PLUS WOOD Cavity Drill Bit
Foret coffrage BOIS SDS PLUS L400



ø	10 L400	12 L400	14 L400	16 L400	18 L400	20 L400	22 L400	24 L400	26 L400	28 L400	30 L400
Pcs	1	1	1	1	1	1	1	1	1	1	1

Ref. 4995 - Nº Art. 72174: **590,38 €**

Línea 1m
1644

BROCA ENCOFRADO MADERA SDS PLUS L600

L600 SDS PLUS WOOD Cavity Drill Bit
Foret coffrage BOIS SDS PLUS L600



ø	10 L600	12 L600	14 L600	16 L600	18 L600	20 L600	22 L600	24 L600	26 L600	28 L600	30 L600
Pcs	1	1	1	1	1	1	1	1	1	1	1

Ref. 4995 - Nº Art. 72175: **617,72 €**

Ref. **1643**

BROCA ENCOFRADO MADERA

WOOD Cavity Drill Bit
Foret coffrage BOIS



Aceros
Steel
Aciers

Madera
Wood
Bois



D mm	L mm	l mm	d mm		Nº Art.	€
6	400	57	5	1	23988	9,68
8	400	75	6	1	23989	9,75
10	400	87	8	1	23990	11,43
12	400	100	8	1	23991	14,66
14	400	100	8	1	23992	17,58
16	400	100	10	1	23993	20,88
18	400	100	10	1	23994	27,49
20	400	100	10	1	23995	31,89
22	400	100	10	1	23996	42,67
24	400	100	11	1	23997	50,15
26	400	100	11	1	23999	57,68
28	400	100	11	1	24000	61,46
30	400	100	11	1	24001	68,72

D mm	L mm	l mm	d mm		Nº Art.	€
6	600	57	5	1	24002	10,38
8	600	75	6	1	24004	10,44
10	600	87	8	1	24005	12,19
12	600	100	8	1	24006	15,34
14	600	100	8	1	24007	18,44
16	600	100	10	1	24008	21,99
18	600	100	10	1	24009	29,07
20	600	100	10	1	24010	33,21
22	600	100	10	1	24011	44,96
24	600	100	11	1	24012	55,59
26	600	100	11	1	24013	60,03
28	600	100	11	1	24014	63,78
30	600	100	11	1	24015	71,93

Display
41



54
cm

Display
42



74
cm

∅	6	8	10	12	14	16	18	20
	L400	L400	L400	L400	L400	L400	L400	L400
Pcs	2	2	2	2	2	2	2	2

Ref. 4995 - Nº Art. 22629: **286,70 €**

∅	6	8	10	12	14	16	18	20
	L600	L600	L600	L600	L600	L600	L600	L600
Pcs	2	2	2	2	2	2	2	2

Ref. 4995 - Nº Art. 22630: **302,11 €**

Ref. **1621**

BROCA MADERA

Wood Drill Bit
Foret Bois



Maderas Blandas
Soft Wood
Bois tendre

D mm	L mm	l mm	d mm		Nº Art.	€
3,00	47	16	6,35	1	56002	2,88
4,00	53	20	6,35	1	56004	2,67
5,00	59	26	6,35	1	56005	2,54
6,00	59	26	6,35	1	56006	2,43
8,00	59	32	6,35	1	56008	2,61

Línea 33 cm
1621

BROCA MADERA

Wood Drill Bit
Foret Bois



∅	3	4	5	6	8
Pcs	5	5	5	5	5

Ref. 4995 - Nº Art. 72201: 65,62 €

Ref. **1461**

SET BROCAS MANGO HEXAGONAL 1/4" Y PUNTAS DE ATORNILLAR

Hexagonal Shank Drill Bit and Screwdriver Bit Set
Jeu de forets hexagonales et embouts vissage



17
pcs

Brocas Madera
Wood Drill Bits
Forets Bois
3- 4 - 5 - 6 mm

d mm: 6,35

Tx
T10
T15
T20
T25
T30
T40

PH d mm: 6,35
PH1
PH2
PH3

Adapt. Quick-Lock
L mm: 60 - d mm: 6,35

PZ d mm: 6,35
PZ1
PZ2
PZ3

Nº Art. €
81601 18,52



Display 54



BROCAS METAL + PARED + MADERA

Metal + Masonry + Wood Drill Bits
Forets Métal + Maçonnerie + Bois

Ref. 1611								
∅	2	3	3,25	3,5	4	5	6	8
Pcs	3	3	3	3	3	3	3	3

Ref. 1610						Ref. 1601		
∅	M3	M4	M5	M6	M8	M10	4	5
Pcs	2	2	2	2	2	2	3	3

Ref. 1601			Ref. 1621					
∅	6	8	10	3	4	5	6	8
Pcs	3	3	3	3	3	3	3	3

Ref. 4995 - N° Art. 69804: 475,64 €

Ref. 1639

AVELLANADOR MADERA

Shell Drill Bit
Foret outil-lamer-chambrer Bois



HSS



También posible uso como tope para brocas
Also usable as a drill stop
Utilisable comme bague d'arrêt pour forets

D- mm	D+ mm		N° Art.	€
3	16	1	56011	6,52
4	16	1	56012	6,52
5	16	1	56013	6,52
6	16	1	56014	6,52
8	20	1	56016	8,10
10	20	1	56018	8,10



Línea 33 cm 1639

AVELLANADOR MADERA

Shell Drill Bit
Foret outil-lamer-chambrer Bois



∅	3x16	4x16	5x16	6x16	8x20	10x20
Pcs	2	2	2	2	2	2

Ref. 4995 - N° Art. 72160: 84,56 €



Ref. **1637**

TOPE PROFUNDIDAD DE BROCA

Drill Bit Depth Stop
Butées de perçage

New!



C45

D mm		Nº Art.	€
3,00	1	13762	2,32
4,00	1	13763	2,60
5,00	1	13764	2,84
6,00	1	13765	3,18
8,00	1	13766	3,38
10,00	1	13767	3,58

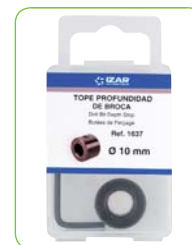

Set 6 Pcs

Cont. Ø	Nº Art.	€
3-4-5-6-8-10 mm	81689	17,89

Ref. **1461**

SET TOPES DE PROFUNDIDAD DE BROCAS

Drill Bit Depth Stop Set
Jeu butées de perçage



13
pcs

Brocas
Drill Bits
Forets

3-4-5-6-8-10 mm

Topes de profundidad
Depth Stops
Butées de perçage



3-4-5-6-8-10 mm

Nº Art.

€

79876 **28,43**

Llave Allen / Allen Wrench / Clé Allen 1 pc

FRESAS

Router Cutters

Fraises

Ref. **1685**

FRESA RANURADO Y COPIADO CON CENTRADOR

Straight Bit with Centre Tip
Fraise rainurage et copiage avec pointe



MD
HM
Carbure

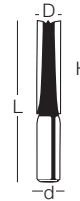
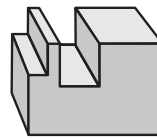

D mm	d mm	L mm	H mm		Nº Art.	€
3,00	8,00	37,0	6	1	69222	19,22
4,00	8,00	41,0	10	1	69225	19,22
5,00	8,00	43,0	12	1	69228	20,66
6,00	8,00	48,0	14	1	69231	20,66

D mm	d mm	L mm	H mm		Nº Art.	€
8,00	8,00	51,0	20	1	69234	21,45
10,00	8,00	50,0	20	1	69237	21,45
12,00	8,00	50,0	20	1	69240	23,01

Ref. **1669**

FRESA RANURADO Y COPIADO

Straight Bit
Fraise rainurage et copiage



MD
HM
Carbure

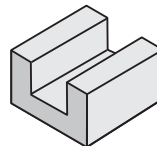

D mm	d mm	L mm	H mm			Nº Art.	€
3,00	8,00	47,0	11,0	1	1	36312	16,71
4,00	8,00	47,0	11,0	1	1	36313	16,71
5,00	8,00	47,0	11,0	1	1	36314	17,97
6,00	8,00	48,0	16,0	2	1	36315	17,97
8,00	8,00	51,0	20,0	2	1	36316	18,66
10,00	8,00	51,0	20,0	2	1	36317	18,66
12,00	8,00	51,0	20,0	2	1	36318	20,01

D mm	d mm	L mm	H mm			Nº Art.	€
14,00	8,00	51,0	20,0	2	1	36319	21,48
16,00	8,00	51,0	20,0	2	1	36320	23,12
18,00	8,00	51,0	20,0	2	1	36321	24,00
20,00	8,00	51,0	20,0	2	1	36322	26,05
22,00	8,00	59,0	25,0	2	1	36323	27,08
24,00	8,00	43,5	11,5	2	1	36324	27,79

Ref. **1679**

FRESA REBAJADO CON COPIADOR

Rabbeting Bit
Fraise réduction avec copieur



MD
HM
Carbure

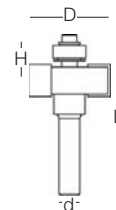
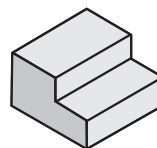

D mm	d mm	L mm	H mm		Nº Art.	€
28,50	8,00	54,0	12,7	1	69279	32,36

Ref. **1678**

FRESA REFUNDIDO RECTO CON COPIADOR

Flush Trim Bit
Fraise fusionage droit avec copieur



MD
HM
Carbure

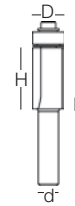
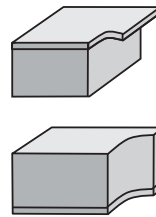

D mm	d mm	L mm	H mm		Nº Art.	€
12,70	8,00	57,0	25,4	1	36343	25,38

Ref. **1674**

FRESA RANURAS EN "V"

"V" Grooves Bit
Fraise rainures "V"



MD
HM
Carbure

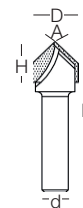
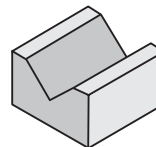

D mm	d mm	L mm	H mm	A		Nº Art.	€
12,70	8,00	45	12,7	90°	1	60757	20,89
16,00	8,00	48	12,7	90°	1	69212	23,58
19,00	8,00	51	16,0	90°	1	69214	27,87

Ref. **1676**

FRESA COLA DE MILANO CON PRECORTADOR

Dovetail Bit
Fraise queue d'aronde avec precoupeur



MD
HM
Carbure

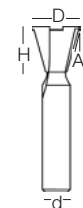
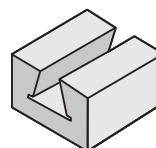

D mm	d mm	L mm	H mm	A		Nº Art.	€
12,70	8,00	45	12	14°	1	60758	31,42

Ref. **1677**

FRESA BISELADO CON COPIADOR

Bevel Trim Bit
Fraise biseautage avec copieur



MD
HM
Carbure

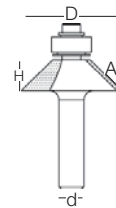
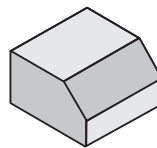

D mm	d mm	L mm	H mm	A		Nº Art.	€
31,80	8,00	56	15	45°	1	36356	29,45

Ref. **1670**

FRESA RADIO CÓNCAVO

Core Box Bit
Fraise rayon concave



MD
HM
Carbure

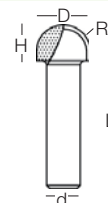
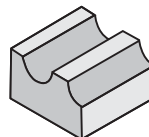

D mm	d mm	L mm	H mm	R		Nº Art.	€
9,50	8,00	40	9,5	4,8	1	36328	25,86
12,70	8,00	40	12,7	6,3	1	36329	27,60

Ref. **1671**

FRESA RADIO CÓNCAVO CON COPIADOR

Cove Bit
Fraise rayon concave avec copieur



MD
HM
Carbure

3 Z

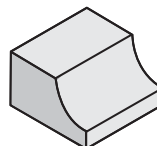

D mm	d mm	L mm	H mm	R		Nº Art.	€
28,50	8,00	56	14	9,5	1	60759	39,71
35,00	8,00	59	16	12,7	1	60760	47,11

Ref. **1672**

FRESA REDONDEADO CANTOS CON COPIADOR

Beading Bit
Fraise arrondir les bouts avec copieur



MD
HM
Carbure

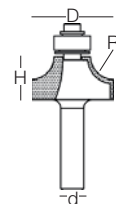
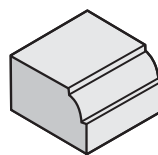

D mm	d mm	L mm	H mm	R		Nº Art.	€
25,40	8,00	55,0	13,5	6,3	1	36332	43,41
28,60	8,00	56,0	15,9	7,9	1	36333	45,79
31,80	8,00	58,7	16,7	9,5	1	36334	49,28
38,10	8,00	62,0	19,0	12,7	1	36335	57,34

Ref. **1673**

FRESA REDONDEADO CANTOS CON COPIADOR

Round Over Bit
Fraise arrondir les bouts avec copieur



MD
HM
Carbure

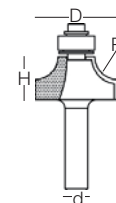
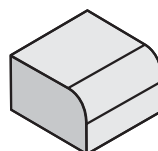

D mm	d mm	L mm	H mm	R		Nº Art.	€
25,40	8,00	54,0	13,5	6,3	1	36336	43,41
28,60	8,00	55,0	15,9	7,9	1	36337	45,79
31,80	8,00	56,0	16,7	9,5	1	36338	49,28
38,10	8,00	62,0	19,0	12,7	1	36339	57,34

Ref. **1681**

FRESA PERFILADO CON COPIADOR

Roman Ogee Bit
Fraise profilage avec copieur



MD
HM
Carbure

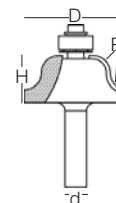
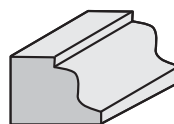

D mm	d mm	L mm	H mm	R		Nº Art.	€
34,90	8,00	60,0	17,4	6,30	1	60762	61,70

Ref. **1682**

FRESA PERFILADO

Classical Roman Ogee Bit
Fraise profilage



MD
HM
Carbure

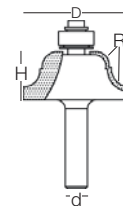
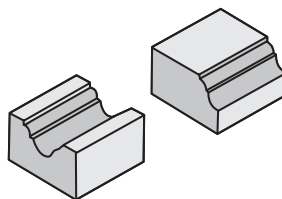

D	d	L	H	R		Nº	€
mm	mm	mm	mm			Art.	
35,00	8,00	57	15,9	4,80	1	60763	41,23

Ref. **1686**

FRESA PERFILADO

Ogee Bit
Fraise profilage



MD
HM
Carbure

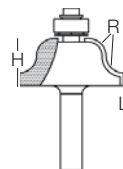
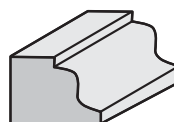

D	d	L	H	R		Nº	€
mm	mm	mm	mm			Art.	
31,80	8,00	54	12,7	4,8	1	69699	48,24
38,00	8,00	57	15,9	6,3	1	69701	55,12



Línea 1m 16FM

FRESAS MADERA

Wood Router Cutters
Fraises Bois



Ref.	1669	1669	1669	1669	1669	1669	1669	1670	1670	1674	1674	1676	1677	1678	1679	1686	1681	1682	1685
∅	5	6	8	10	12	14	16	9,5	12,7	12,7	16	12,7	31,80	12,7	28,5	31,8	34,90	35	12
Pcs	1	1	1	1	1	1	1	1	1	1	1	1	1	1	1	1	1	1	1

Ref. 4995 - N° Art. 72181: 528,59 €

Display 64

FRESAS MADERA

Wood Router Cutters
Fraises Bois



Ref.	1669	1669	1669	1669	1669	1669
∅	5	6	8	10	12	14
Ref.	1669	1670	1670	1671	1671	1672
∅	16	9,5	12,7	28,5	35	28,6
Ref.	1672	1672	1673	1673	1673	1674
∅	31,8	38,1	28,6	31,8	38,1	12,7
Ref.	1674	1676	1677	1678	1679	1681
∅	16	12,7	31,80	12,7	28,5	34,90
Ref.	1686	1682	1685	1685	1685	1685
∅	31,8	35	6	8	10	12

N° Art. 39710: 983,77 €

Ref. **1615**

BROCA-FRESA INSTALADORES

TCT Hinge Boring Bit
Mèche à façonner installateurs



Diente MD
Carbide Tipped
Dent Carbure



Maderas Duras
Hard Wood
Bois dur

Maderas Blandas
Soft Wood
Bois tendre

Indicado carpinteros y ebanistas, para instalación de ventanas, puertas y cocinas en todo tipo de maderas y materiales abrasivos.

Suitable for carpenters and cabinet-makers installing windows, doors & kitchens in all wood types and abrasive materials.

Idéal pour Charpentiers et Menuisiers pour installation de fenêtres, portes et cuisines tout genre de surfaces et matériaux abrasifs.

D mm	d mm	L mm	l mm		Nº Art.	€
15	8	90	10,00	1	23039	12,18
18	8	90	10,00	1	23040	14,47
20	8	90	12,50	1	23041	15,91
22	8	90	12,50	1	23042	17,37
24	8	90	12,50	1	23043	19,13
25	8	90	12,50	1	23044	19,95
26	8	90	14,50	1	23045	20,67
30	8	90	14,50	1	23046	22,68
35	10	90	14,50	1	23047	27,21
40	10	90	16,50	1	23048	30,97

Línea 33 cm
1615

BROCA-FRESA INSTALADORES

TCT Hinge Boring Bit
Mèche à façonner installateurs

21
cm



ø	20	25	26	35
Pcs	2	2	2	2

Ref. 4995 - Nº Art. 72183: 167,48 €



Ref. **1620**

BROCA-FRESA MADERA

WOOD Forstner Bit
Mèche a façonner BOIS



HSS

Maderas Duras
Hard Wood
Bois dur

Maderas Blandas
Soft Wood
Bois tendre



Apropiado para todo tipo de maderas naturales, blandas y nobles.

Ideal for use in all natural soft and hard woods.

Idéal pour tout genre de bois naturels, tendres et nobles.

D mm	d mm	L mm	l mm		Nº Art.	€
10	8	90	8,20	1	18189	5,38
12	8	90	8,60	1	18190	5,55
14	8	90	9,00	1	18192	5,84
15	8	90	9,20	1	18193	5,93
16	8	90	9,50	1	18195	6,02
18	8	90	10,00	1	18196	7,19
20	8	90	10,30	1	18198	6,65

D mm	d mm	L mm	l mm		Nº Art.	€
22	8	90	10,80	1	18199	7,57
24	8	90	11,30	1	18201	7,75
25	8	90	11,50	1	18202	7,87
26	8	90	11,70	1	18204	8,51
28	8	90	12,20	1	18205	7,38
30	8	90	12,60	1	18206	7,38
32	10	90	13,00	1	18207	9,68

D mm	d mm	L mm	l mm		Nº Art.	€
34	10	90	13,50	1	18208	10,21
35	10	90	13,70	1	18210	10,55
40	10	90	14,80	1	18213	11,96
45	10	90	15,80	1	18214	13,44
50	10	90	17,20	1	18216	14,61

Línea 33 cm
1620

BROCA-FRESA MADERA

WOOD Forstner Bit
Mèche a façonner BOIS



ø	16	20	26	35	40
Pcs	2	2	2	2	2

Ref. 4995 - Nº Art. 72185: **87,38 €**

Ref. **1625**

BROCA-FRESA BISAGRAS

Cantilever Hinge Bit
Mèche à façonner charnières



MD
HM
Carbure



D mm	d mm	L mm	l mm		Nº Art.	€
26	8	54	7,50	1	24476	18,79
30	8	54	8,00	1	24477	18,79
35	8	54	8,20	1	24478	19,24

Línea 33 cm
1625

BROCA-FRESA BISAGRAS

Cantilever Hinge Bit
Mèche à façonner charnières



ø	26	30	35
Pcs	2	2	2

Ref. 4995 - Nº Art. 72187: **113,63 €**

Ref. **1689**

FRESA ESPUMAS EVA* Y MADERA

EVA Foam & Wood End Mill
Fraise caoutchouc EVA et Bois



**MD
HM**
Carbure

IZAR
Std.

**2
Dientes**
Teeth/Dents

*** Etilvinilacetato**
Ethylene-vinyl acetate
Éthylène-acétate de vinyle

Espumas EVA
Foam
Caoutchouc

Madera
Wood
Bois

Plásticos
Plastics
Plastiques

D mm	d mm	L mm	l mm	Z		Nº Art.	€
01,00	3	38	3	2	1	79346	8,69
01,50	3	38	7	2	1	79421	8,69
02,00	3	38	17	2	1	79422	8,69
02,50	3	38	17	2	1	79423	8,69
03,00	3	55	32	2	1	79435	9,80
04,00	4	65	42	2	1	79436	18,37
06,00	6	70	42	2	1	79437	24,16
08,00	8	75	42	2	1	79438	37,74
10,00	10	85	42	2	1	79440	71,91



- **Geometría Multi Material válida para una amplia gama de productos como espumas, acrílicos, PVC, ABS, tableros, madera contrachapada, resinas, nylon, etc.**
- **Special Multi Material geometry suitable for a wide range of products such as foams, acrylic, PVC, ABS, hardwood, plywood, resins, nylon, etc.**
- **Géométrie Multi Matériaux pour une gamme large de produits comme mousses, acryliques, PVC, ABC, tableaux, bois contreplaqués, résines, nylon, etc.**
- **Mecanizado de las bandejas de herramientas.**
- **Machining of tool trays.**
- **Usinage de plateaux d'outils.**



Ref. **9001**

BROCA-FRESA ROTOZIP® / ROTOCUT® METAL

Metal Rotozip® / Rotocut® Cutout Bit
Foret-Fraise Rotozip® / Rotocut® Métal



**MD
HM**
Carbure



Chapas finas de metal
Thin metal sheets
Tôles fines

D mm	Pulgadas Inches / Pouces	L	l			Nº Art.	€
3,97	5/32	50,00	11	2	2	67805	29,55

Ref. **7009**

BROCA-FRESA ROTOZIP® / ROTOCUT® CERÁMICAS

Ceramic Rotozip® / Rotocut® Cutout Bit
Foret-Fraise Rotozip® / Rotocut® Céramique



MD
HM
Carbure



Argamasa, Azulejos Cerámica, Estuco, Mármol, Placas Cemento, Yeso

Concrete Panels, Ceramic Tiles, Marble, Mortar, Plaster, Stucco
Mortier, Carreaux Faïence Céramique, Stuc, Marbre, Plaques de ciment, Plâtre

D mm	Pulgadas Inches / Pouces	L	I		Nº Art.	€
3,18	1/8	45,00	21,00	1	18933	16,40
6,35	1/4	42,50	20,50	1	18939	27,49

Ref. **7002**

BROCA-FRESA ROTOZIP® / ROTOCUT® ESCAYOLA

Drywall Rotozip® / Rotocut® Cutout Bit
Foret-Fraise Rotozip® / Rotocut® Plâtre





HSS

Pladur

Escayola
Drywall
Plâtre

Escayola, Muros Prefabricados

Drywall, Prefabricated Walls
Plâtre, Murs Préfabriqués

D mm	Pulgadas Inches / Pouces	L	I			Nº Art.	€
3,18	1/8	58,00	35,00	1	1	18927	4,09



Ref. **7003**

BROCA-FRESA ROTOZIP® / ROTOCUT® AUTO-GUÍA

Autocenter Rotozip® / Rotocut® Cutout Bit
Foret-Fraise Rotozip® / Rotocut® autocentré



HSS

Auto-center

Escayola, Espuma, Muros Prefabricados
Drywall, Foam, Prefabricated Walls
Plâtre, Mousse, Murs Préfabriqués

D mm	Pulgadas Inches / Pouces	L	I	Z	Art.	Nº Art.	€
3,18	1/8	60,00	35,00	1	2	19002	4,09
3,97	5/32	75,00	40,00	1	2	67795	5,25
6,35	1/4	82,00	44,00	1	1	18930	9,16

Ref. **7001**

BROCA-FRESA ROTOZIP® / ROTOCUT® MADERA

Wood Rotozip® / Rotocut® Cutout Bit
Foret-Fraise Rotozip® / Rotocut® Bois



HSS



Aglomerado, Aluminio, Espuma, Fibra Vidrio, Laminados, Plástico, Plexiglás, Vinilo
Aluminium, Chipboard, FibreGlass, Foam, Laminated, Plastics, Plexiglas, Vinyl
Agglomérat, Aluminium, Mousse, Fibre de Verre, Laminés, Plastiques, Plexiglas, Vinyle

D mm	Pulgadas Inches / Pouces	L	I	Z	Art.	Nº Art.	€
3,18	1/8	70,00	35,00	1	2	18999	4,09



Ref. **1690**

CUCHILLA CEPILLOS ELÉCTRICOS

Planner Blade
Lame à surfacer

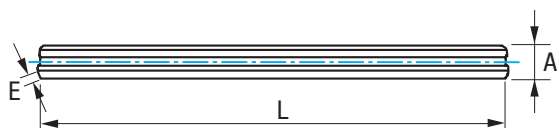

MD
HM
Carbure



L	A	E		N°	€
mm	mm	mm	Art.		
82	5,5	1,10	2	60635	3,58 *

* € = 1 ud.





SIERRAS

Saw Blades
Lames scies

OSCILANTES MULTI-FUNCIÓN

Oscillating Multi-Tools
Outils multifonction

298

SIERRAS SABLE

Sabre Saw Blades
Lames scie sabre

320

SIERRAS CALAR





















































Jig Saw Blades
Lames scies sauteuses

336



CUADRO USO SIERRAS OSCILANTES MULTI-FUNCIÓN

Oscillating Multi-Tool Table
Tableau utilisation outils multifonction

		STARLOCK															
		MADERA - Wood - Bois							METAL								
		Ref.	2940	2940	2940	2940	2940	2940	2940	2910	2910	2910	2910	2910	2910	2910	2910
Mod.	00010	00020	00030	00040	00050	00060	00070	00010	00020	00030	00040	00050	00060	00070	00080	00090	00100
Mat.	HCS	HCS	Bimetal	HCS	HCS	Bimetal	HCS	MD HM	MD HM	Bimetal	Bimetal	Bimetal	Bimetal	Bimetal	Bimetal	Bimetal	Bimetal + TIN
																	
																	
	Madera Blanda Soft Wood / Bois tendre	●	○	○	●	○	○	●	○	○	○	○	○	○	○	○	○
	Madera Dura Hard Wood / Bois dur		●	●		●	●			○	○	○	○	○	○	○	
	Madera+Clavos Wood+Nails / Bois+Clous							○	○		○		○	○			
	Metal							○	○	○	○	○	○	○	○	○	
	INOX / Stainless / Inox							○	○				○				
	Plástico / Plastics / Plastique	○			○		○			○	○	○		○	○	○	
	Fibra Vidrio Fibreglass / Fibre verre							○	○								
	Abrasivos Abrasive / Abrasifs							○	○								
	Pladur / Drywall / Plâtre							○	○	○	○	○					
	No ferrosos Non-ferrous / Non ferreux									○	○	○	○				
	Perfiles / Profiles / Profils														○	○	
	Parquet-Laminados Laminated-Parquet Parquet-Laminés														○	○	
	GFK															○	
	Cerámica Ceramics / Céramique																
	Grout-Mortero Grout-Mortar Coulies-Mortier																
	Pulido / Sanding / Poncer																
	Aislamiento Isolating / Isolant																
	Caucho Rubber / Caoutchouc																
	Cuero / Leather / Cuir																
	Restos blandos (pegamento, moqueta, silicona...) Soft remains (glue, carpet, silicone...) Restes tendres (colle, moquette, silicone...)																

CUADRO USO SIERRAS OSCILANTES MULTI-FUNCIÓN

Oscillating Multi-Tool Table
Tableau utilisation outils multifonction

STARLOCK													QUICK-FIT				SUPERCUT		
ESPECIAL - Special - Spécial													ESPECIAL - Special - Spécial				ESPECIAL		
2930	2930	2930	2930	2930	2930	2930	2930	2930	2930	2930	2930	2930	2950	2950	2950	2950	2960	2960	Ref.
00010	00020	00030	00040	00050	00060	00070	00080	00090	00100	00110	00120	00130	00010	00020	00030	00040	00010	00020	Mod.
	MD HM	MD HM	MD HM	MD HM	MD HM	MD HM	MD HM	Dia- mante	Bimetal	HCS	HCS	HCS	HCS	Bimetal	Bimetal		Bimetal	Bimetal	Mat.
			○	○									●	●	●		○	○	
			○	○									○	○	○		○	○	
														○			●	●	
			○	○													○	○	
	●	●																	
●	●		●	●															
									●										
									●										
									●										
										●									

OSCILANTES MULTI-FUNCIÓN

Oscillating Multi-Tools Outils multifonction

LA GAMA MÁS COMPLETA PARA TODOS LOS MATERIALES

The most complete range for every material

La gamme plus complète pour tous les matériaux

Para serrar, cortar, rascar, fresar y escofinar
For sawing, cutting, scraping, milling and rasping
Pour scier, couper, fraiser et gratter

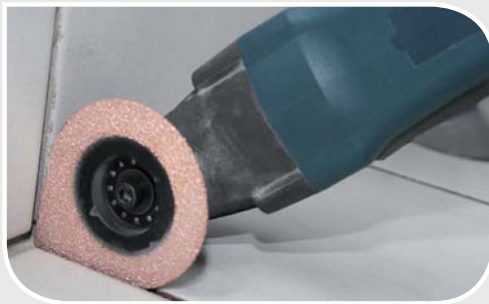

COMPATIBILIDAD / Compatibility / Compatibilité

Starlock:

Bosch GOP 12-28, PMF 220 CE, PMF 250 CES

Starlock Plus:

Bosch GOP 30-28, Bosch GOP 40-30, Bosch GOP 18V-28, Bosch PMF 350 CES, Fein AFMT 12 SL, Fein AFMT 12 QSL, Fein AFMM 18 QSL, Fein FMT 250 SL, Fein FMT 250 QSL, Fein FMM 350 QSL, Fein Multimaster, Fein Multitalent

Starlock Max:

Bosch GOP 55-36, Fein AFSC 18 QSL, Fein AFSC 18 QC SL, Fein FSC 500 QSL

OTROS Others Autres:

Bosch GOP, Bosch PMF, Fein Multimaster, Fein Multitalent, Makita, Hitachi, Metabo, Milwaukee, AEG, Einheil, Ryobi, Skil...

STARLOCK



MADERA
Wood
Bois



METAL



ESPECIAL
Special
Spécial

IZAR
CUTTING TOOLS



STARLOCK

OSCILANTES MULTI-FUNCIÓN

Oscillating Multi-Tools
Outils multifonction

Ref. **2940**

MADERA Wood Bois



STARLOCK



Mod **00010**

CORTE CURVO MADERAS BLANDAS

Curve Cutting in Soft Wood
Coupe courbe pour bois tendre

Mod.		Nº Art.	€
00010	1	69095	19,31

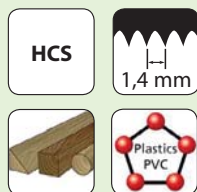
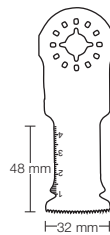

Corte limpio y preciso en maderas blandas y plásticos. Filos de corte redondeados para evitar sacudidas y conseguir una profundización suave del corte. Serrado cerca de bordes, en esquinas y zonas de difícil acceso, como p.e. ventanas estrechas para montar rejillas de ventilación.

Clean and precise cuts in softwood and plastics. Rounded cutting edges for jolt-free and smooth plunge cutting. Sawing near edges and difficult-to-reach areas, such as tight windows to install grilles.

Coupe propre et précise sur bois tendres et plastiques. Filets de coupe arrondis pour éviter les secouées et obtenir une profondeur plus douce de la coupe. Serrage près des bords, en corners et surfaces d'accès difficile, comme fenêtres étroites pour fixer des grilles de ventilation.



Mod **00020**

CORTE CURVO MADERAS DURAS

Curve Cutting in Hard Wood
Coupe courbe pour bois dur

Mod.		Nº Art.	€
00020	1	69096	19,31

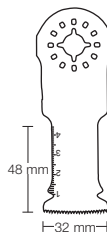

Corte limpio y preciso en maderas, sobre todo duras. Filos de corte redondeados para evitar sacudidas y conseguir una profundización suave del corte.

Clean and precise cuts in Wood, specially in hard wood. Rounded cutting edges for jolt-free and smooth plunge cutting.

Coupe propre et précise sur bois, surtout durs. Filets de coupe arrondis pour éviter les secouées et obtenir une profondeur plus douce de la coupe.



Mod **00030**

CORTE CURVO ALTO RENDIMIENTO MADERAS DURAS

High Performance Curve Cutting in Hard Wood

Coupe courbe haut rendement pour bois dur

Mod.		N°	Art.	€
00030	1	69097		23,98

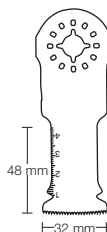

Bimetal 1,8 mm

Dentado japonés
Japanese Teeth
Denture japonais

Corte limpio y preciso en maderas, sobre todo duras. Filos de corte redondeados para evitar sacudidas y conseguir una profundización suave del corte.

Clean and precise cuts in Wood, specially in hard wood. Rounded cutting edges for jolt-free and smooth plunge cutting.

Coupe propre et précise sur bois, surtout durs. Filets de coupe arrondis pour éviter les secouées et obtenir une profondeur plus douce de la coupe.



Mod **00040**

CORTE CURVO MADERAS BLANDAS

Curve Cutting in Soft Wood

Coupe courbe pour bois tendre

Mod.		N°	Art.	€
00040	1	69099		22,26

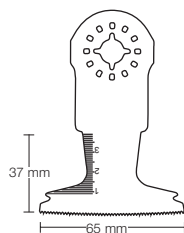

HCS 1,3 mm

Plastics
PVC

Corte limpio y preciso en maderas blandas y plásticos. Filos de corte redondeados para evitar sacudidas y conseguir una profundización suave del corte.

Clean and precise cuts in softwood and plastics. Rounded cutting edges for jolt-free and smooth plunge cutting.

Coupe propre et précise sur bois, surtout durs. Filets de coupe arrondis pour éviter les secouées et obtenir une profondeur plus douce de la coupe.



Mod **00050**

CORTE CURVO MADERAS DURAS

Curve Cutting in Hard Wood
Coupe courbe pour bois dur

Mod.		N° Art.	€
00050	1	69102	22,67

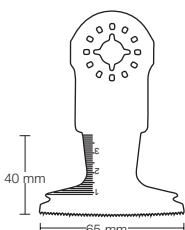

HCS	1,8 mm
	Dentado japonés Japanese Teeth Denture japonais

Corte limpio y preciso en maderas, sobre todo duras. Filos de corte redondeados para evitar sacudidas y conseguir una profundización suave del corte.

Clean and precise cuts in Wood, specially in hard wood. Rounded cutting edges for jolt-free and smooth plunge cutting.

Coupe propre et précise sur bois, surtout durs. Filets de coupe arrondis pour éviter les secouées et obtenir une profondeur plus douce de la coupe.



Mod **00060**

CORTE CURVO ALTO RENDIMIENTO MADERAS DURAS

High Performance Curve Cutting in Hard Wood
Coupe courbe haut rendement pour bois dur

Mod.		N° Art.	€
00060	1	69103	27,69

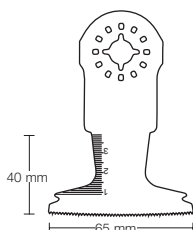

Bimetal	1,8 mm
	Dentado japonés Japanese Teeth Denture japonais

Corte limpio y preciso en maderas, sobre todo duras. Filos de corte redondeados para evitar sacudidas y conseguir una profundización suave del corte.

Clean and precise cuts in Wood, specially in hard wood. Rounded cutting edges for jolt-free and smooth plunge cutting.

Coupe propre et précise sur bois, surtout durs. Filets de coupe arrondis pour éviter les secouées et obtenir une profondeur plus douce de la coupe.

Mod **00070****HOJA SIERRA SEGMENTADA**

Segmented Saw Blade

Lame segmenté

Mod.		Nº	Art.	€
00070	1	69104	22,34	

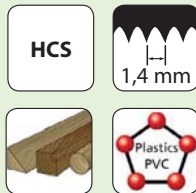
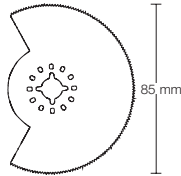

Corte limpio y preciso en maderas y plásticos. Tronzado de tubos de plástico, rejillas de ventilación, espigas salientes en uniones de madera. Recorte de molduras o marcos de puerta ya instalados; cortes de inmersión para ajustar tarimas.

Clean and precise cutting of wood and plastic. Parting of plastic pipes, grilles, protrusions in wood-unions. Installed (door) frames cutting; wood flooring plunge cutting.

Coupe propre et précise sur bois et plastiques. Tronçage sur tube en plastiques, grilles de ventilation, chevilles d'union en bois. Coupure des cadres de portes déjà installés, coupes d'immersion pour fixer les parquets.







Mod **00010**

ALTO RENDIMIENTO INOX / CLAVOS

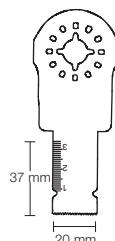
Heavy Duty Stainless / Nails
Haut rendement Inox / Clous

Mod.		N°	Art.	€
00010	1	69105		30,95



MD HM Carbure	 1,1 mm	
Inox Stainless		

Corte limpio y preciso en metal, inoxidable, tornillos, clavos, fibra vidrio, abrasivos, pladur, barras de hierro, tubos negros, grapas.

Clean and precise cuts in metal, stainless Steel, hardened screws, nails, fibreglass, abrasives, drywall, iron bars, black pipes, staples.

Coupe propre et précise sur aciers, Inox, vis, clous, fibre de verre, abrasifs, barreaux de fer, tubes noirs et agrafes.





Mod **00020**

ALTO RENDIMIENTO INOX / CLAVOS

Heavy Duty Stainless / Nails
Haut rendement Inox / Clous

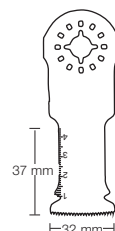
Mod.		N°	Art.	€
00020	1	69106		38,32



MD HM Carbure	 1,1 mm	
Inox Stainless		

Corte limpio y preciso en metal, inoxidable, tornillos, clavos, fibra vidrio, abrasivos, pladur, barras de hierro, tubos negros, grapas.

Clean and precise cuts in metal, stainless Steel, hardened screws, nails, fibreglass, abrasives, drywall, iron bars, black pipes, staples.

Coupe propre et précise sur aciers, Inox, vis, clous, fibre de verre, abrasifs, barreaux de fer, tubes noirs et agrafes.







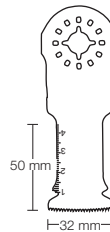

Mod **00060**

CORTE CURVO Y RÁPIDO METAL / MADERA / CLAVOS

Curve & Fast Cutting in Metal / Wood / Nails
Coupe courbe et rapide dans Métal / Bois / Clous

Mod.		Nº Art.	€
00060	1	69111	23,98



Bimetal	 1,3 mm		
 Plastics PVC			

Corte limpio y preciso en metal, madera, maderas con clavos, plásticos y materiales no ferrosos. Filos de corte redondeados para evitar sacudidas y conseguir una profundización suave del corte.

Clean and precise cuts in metal, wood, wood with nails, plastics and non-ferrous materials. Rounded cutting edges for jolt-free and smooth plunge cutting.

Coupe propre et précise sur aciers, bois, bois avec clous, plastiques et aciers non ferreux. Filets de coupe arrondis pour éviter des secouées et obtenir une profondeur plus douce de la coupe.







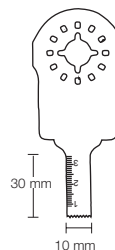

Mod **00030**

CORTE RECTO METAL / MADERA

Straight Cut Metal / Wood
Coupe droite Métal / Bois

Mod.		Nº Art.	€
00030	1	69107	13,88



Bimetal	 1,3 mm		
 Plastics PVC			

Corte limpio y preciso en metal, madera y plásticos, metales no ferrosos, cerraduras, pladur. Aberturas para cajas de enchufe, separación de tubos de cobre a ras de superficie, cortes de inmersión en paneles de cartón enyesado.

Clean and precise cuts in metal, Wood and plastics, non-ferrous metals, locks, drywall. Opening of socket-boxes, separating copper pipes at surface level, plunge cutting in plastered carton-panels.

Coupe propre et précise sur aciers, bois et plastiques, aciers non ferreux, serrures. Ouvertures pour prises, séparation de tubes en cuivres à ras de sol, coupe d'immersion sur panneaux en plâtre.



Mod **00040**

CORTE RECTO METAL / MADERA

Straight cutting of Metal / Wood
Coupe droit Métal / Bois

Mod.		N° Art.	€
00040	1	69108	14,61

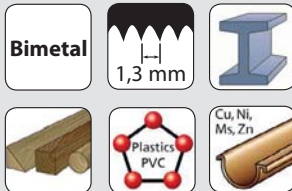
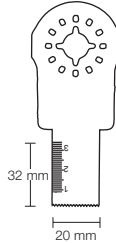

Corte limpio y preciso en metal, madera, plásticos y materiales no ferrosos, pladur, clavos, tubos a ras de superficie.

Clean and precise cuts in metal, Wood, plastics and non-ferrous materials, drywall, nails, pipes at the level of the surface.

Coupe propre et précise sur aciers, bois, plastiques et aciers non ferreux, clous, tubes à ras de sol.



Mod **00050**

CORTE RECTO METAL / MADERA

Straight cutting of Metal / Wood
Coupe droit Métal / Bois

Mod.		N° Art.	€
00050	1	69109	20,91

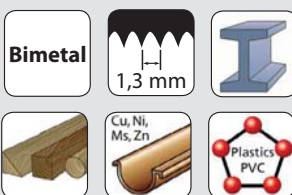
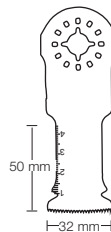

Corte limpio y preciso en metal, madera, plásticos y materiales no ferrosos, pladur.

Clean and precise cuts in metal, Wood, plastics and non-ferrous materials, drywall.

Coupe propre et précise sur aciers, bois, plastiques et aciers non ferreux, plâtre.



Mod 00070

CORTE CURVO Y RÁPIDO METAL / MADERA / CLAVOS

Curve & Fast Cutting in Metal / Wood / Nails

Coupe courbe et rapide dans Métal / Bois / Clous

Mod.		N°	Art.	€
00070	1	69112		29,46

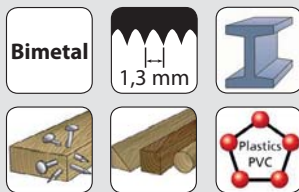
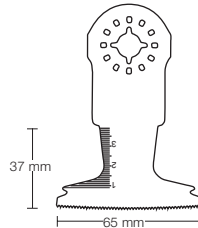

Corte limpio y preciso en metal, madera, maderas con clavos y plásticos. Filos de corte redondeados para evitar sacudidas y conseguir una profundización suave del corte.

Clean and precise cuts in metal, wood, wood with nails and plastics. Rounded cutting edges for jolt-free and smooth plunge cutting.

Coupe propre et précise sur aciers, bois, bois avec clous et plastiques. Filets de coupe arrondis pour éviter des secouées et obtenir une profondeur plus douce de la coupe.



Mod 00080

SIERRA SEGMENTADA. CORTE FINO METAL / MADERA

Segmented Blade. Fine cutting of Metal / Wood

Lame segmenté. Coupe fin dans Métal / Bois

Mod.		N°	Art.	€
00080	1	69113		28,98

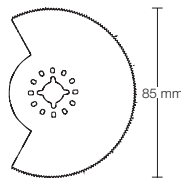

Corte limpio y preciso en metal, madera y plásticos. Recorte de marcos de puertas a ras de suelo, laminados, parquet, listones para perfiles.

Clean and precise cuts in metal, wood, wood with nails and plastics. Door-frame trimming at the level of the floor, laminated, parquet, profile-strips.

Coupe propre et précise sur aciers, bois, bois avec clous et plastiques. Filets de coupe arrondis pour éviter des secouées et obtenir une profondeur plus douce de la coupe.



Mod **00090**

SIERRA SEGMENTADA. ALTO RENDIMIENTO METAL / MADERA

Segmented Blade. High performance in Metal / Wood
Lame segmenté. haut rendement dans Métal / Bois

Mod.		N° Art.	€
00090	1	69114	39,64

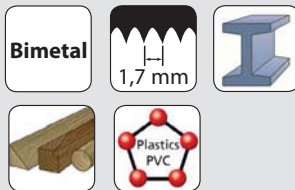
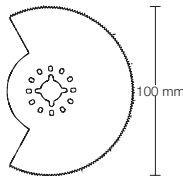

Corte limpio y preciso en metal, madera y plásticos. Recorte de marcos de puertas a ras de suelo, laminados, parqué, listones para perfiles.

Clean and precise cuts in metal, wood, wood with nails and plastics. Door-frame trimming at the level of the floor, laminated, parquet, profile-strips.

Coupe propre et précise sur aciers, bois et plastiques. Coupures de cadres de portes à ras de sol, laminés, parquets et profils.



Mod **00100**

CORTE CURVO MADERAS BLANDAS

Curve Cutting in Soft Wood
Coupe courbe pour bois tendre

Mod.		N° Art.	€
00100	1	69115	41,21

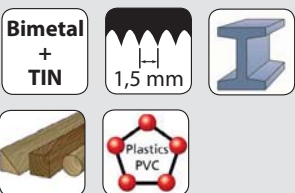
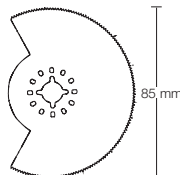

Corte limpio y preciso en metal, madera y plásticos. Dientes recubiertos en titanio para una mayor vida de la herramienta. Corte de entalladuras en epoxy, GFK, listones pequeños para perfiles.

Clean and precise cuts in metal, wood, wood with nails and plastics. Titanium coated teeth for a longer lifetime. Cutting of epoxy-joinings, GFK, small profile-strips.

Coupe propre et précise sur aciers, bois et plastiques. Dents recouverts en titane pour une plus longue vie de l'outil. Coupure dans les bords, petites barres pour profils.



Mod **00010**

PLACA LIJADORA

Sanding Plate
Patin de ponçage

Mod.		Nº Art.	€
00010	1	69116	20,09

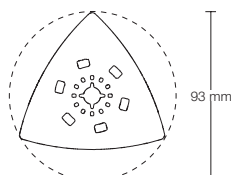

Placa para pulir con fijación tipo micro-velcro.
Sanding plate with micro-velcro type fastening.
Patin de ponçage avec aspiration des poussières.



Mod **00020**

PLACA LIJADORA DESBASTE

Sanding Plate for Roughing
Patin de ponçage ébauche

Mod.		Nº Art.	€
00020	1	69117	38,07

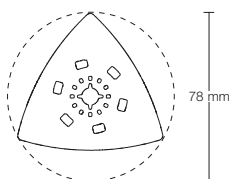

Ideal para eliminar mortero, adhesivo de azulejos y residuos de adhesivos en alfombras, incluso en esquinas gracias a su forma triangular.

Ideal for removing mortar, tile adhesive and carpet adhesive residues even in the corners with the triangle shape.

Conseillé pour supprimer le mortier, colle de carrelage et copeaux collants sur tapis, même aux corners grâce à sa forme triangulaire.

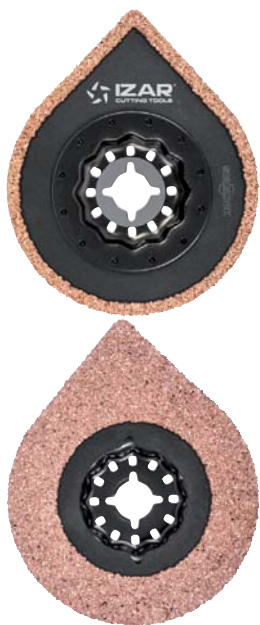





Mod **00030**

SIERRA SEGMENTADA + PLACA LIJADORA

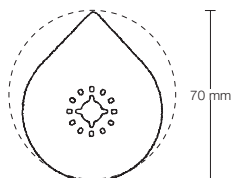
Segmented Saw + Sanding Plate
Lame segmenté à concretion carbure plus patin de ponçage

Mod.		N° Art.	€
00030	1	69118	65,11



MD/HM Carbure K40	2 mm 
	Medium 



Ideal para eliminar grout y mortero de juntas de paredes y suelos, incluso en las esquinas más remotas.

Ideal for removing grout & mortar from Wall and floor tiles, even in the most remote corners.

Conseillé pour supprimer mortier sur joints de murs et sols, même sur les corners plus difficiles.







Mod **00060**

SIERRA INMERSIÓN ABRASIVOS

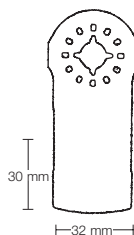
Plunge Saw for Abrasives
Lame immersion abrasifs

Mod.		N° Art.	€
00060	1	69121	38,96



MD/HM Carbure K50	2 mm 	 Fibra Vidrio Fibreglass
	Medium 	



Corte profundo en materiales muy abrasivos como la fibra de vidrio. Filos de corte redondeados para evitar sacudidas y conseguir una profundización suave del corte.

Plunge cutting in strongly abrasive materials, such as fibreglass. Rounded cutting edges for jolt-free and smooth plunge cutting.

Coupe profonde sur matériaux abrasifs comme la fibre de verre. Filets de coupe arrondis pour éviter les secouées et obtenir une profondeur douce de la coupe.





Mod **00040**

SIERRA INMERSIÓN LIJADO FINO

Plunge Saw for Fine Sanding
Râpe à concretion carbure

Mod.	N° Art.	€
00040	1 69119	36,00

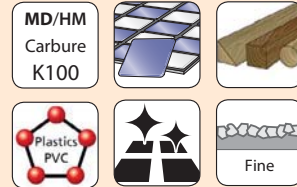
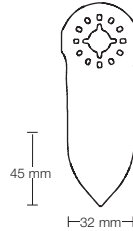

Pulido de residuos de pintura, madera, plásticos, composites, epoxy. Ranurado en espacios estrechos y áreas remotas. Usar a 2/3 de la velocidad máxima. Lijado de madera o pintura en zonas de difícil acceso sin papel de lijar.

Sanding of Paint residues, Wood, plastic, composite, epoxy. Slotting in tight gaps and hard-to-reach areas. Use 2/3 of maximum speed. Sanding of wood or painting in difficult-to-reach areas without sanding-paper.

Dégrossissage de residus de peinture, bois, plastiques et composites. Rainurage sur endroits exigus et zones difficiles. Utilisez à 2/3 de la vitesse maximale. Ponçage de peinture où bois sur zones de difficile accès sans papier de ponçage.



Mod **00050**

SIERRA INMERSIÓN LIJADO DESBASTE

Plunge Saw for Rough Sanding
Râpe à concretion carbure ébauche

Mod.	N° Art.	€
00050	1 69120	36,00

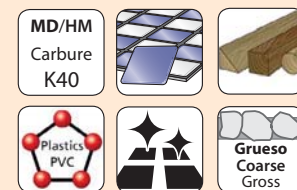
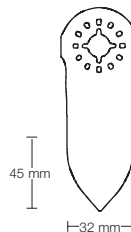

Pulido de residuos de pintura, madera, plásticos, composites, epoxy. Ranurado en espacios estrechos y áreas remotas. Usar a 2/3 de la velocidad máxima.

Sanding of Paint residues, Wood, plastic, composite, epoxy. Slotting in tight gaps and hard-to-reach areas. Use 2/3 of maximum speed.

Dégrossissage de residus de peinture, bois, plastiques et composites. Rainurage sur endroits exigus et zones difficiles. Utilisez à 2/3 de la vitesse maximale.



Mod **00070**

CORTE GRUESO ENTRE AZULEJOS

Rough Cutting among Tiles

Coupe grosse carreaux

Mod.		N° Art.	€
00070	1	69122	42,45

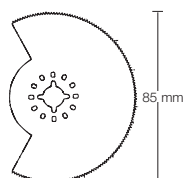

MD/HM Carbure K30	2 mm 	 Fibra Vidrio Fibreglass
	 Grueso Coarse Gross	

Alineado de juntas en azulejos de pared y suelo.

Precise routing joints on wall and floor tiles.

Pour aligner les joints sur carreaux murs et sols.



Mod **00080**

CORTE FINO ENTRE AZULEJOS

Fine Cutting among Tiles

Coupe fine carreaux

Mod.		N° Art.	€
00080	1	69123	36,24

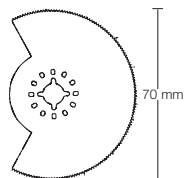

MD/HM Carbure K40	1,4 mm 	 Plastics PVC
	 Medium	

Alineado de juntas en azulejos de pared y suelo.

Precise routing joints on wall and floor tiles.

Pour aligner les joints sur carreaux murs et sols.



Mod **00090**

CORTE DIAMANTE AZULEJOS EXTERIOR

Diamond Cutting of Outer Tiles
Coupe diamant carreaux extérieur

Mod.		Nº Art.	€
00090	1	69124	72,73

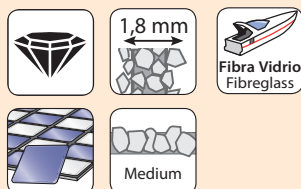
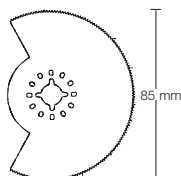

Alineado de juntas en azulejos de pared y suelo. Separación de azulejos, resinas epoxi y plásticos reforzados con fibra de vidrio.

Precise routing joints on wall and floor tiles. Separating of tiles, epoxi gum and fibreglass reinforced plastics.

Pour aligner les joints sur carreaux murs et sols. Séparation de carreaux, résines et plastiques renforcées avec fibre de verre.



Mod **00100**

DENTADO ONDULADO AISLANTES

Waved Teeth for Isolating
Denture vague isolation

Mod.		Nº Art.	€
00100	1	69126	40,76

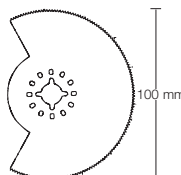

Ideal para materiales de aislamiento como el poliestireno, espuma rígida, materiales blandos como alfombras, caucho, cuero... Cortes a ras de suelo de material sobresaliente.

Ideal for isolating materials, such as polystyrene, rigid foam, soft materials such as carpets, rubber, leather... Cutting of protruding material at floor level...

Conseillé pour matériaux isolation comme le polystyrène, mousse rigide, matériaux tendres comme tapis, cuire... Coupe à ras de sol des matériaux dépassants



Mod **00110**

RASCADORA

Scraper
Racloir

Mod.		N° Art.	€
00110	1	69127	14,08

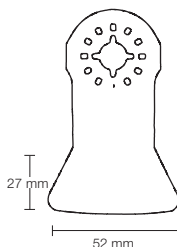

HCS

Restos blandos de pegamento, moqueta, material aglutinante, material de juntas, silicona...
Soft remains of glue, carpet, agglutinative material, joint-material, silicone...
Copeaux tendres de colle, tapis, matière agglutinantes, matériel de jointes, ...



Mod **00120**

DENTADO ONDULADO AISLANTES

Waved Teeth for Isolating
Denture vague isolation

Mod.		N° Art.	€
00120	1	69129	25,32

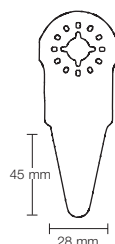

HCS



Abrasivos

Juntas de expansión blanda y materiales de aislamiento, silicona en ventanas.
Soft expanding joints and insulating materials, silicone in windows.
Jointes d'expansion tendres et matériaux. silicones en fenêtres.



Mod **00130**

CORTE PRECISO MATERIALES BLANDOS Y ABRASIVOS

Precise Cutting of Soft Materials and Abrasives
Coupe précis de matériaux moelleux et abrasifs

Mod.		Nº Art.	€
00130	1	69130	30,97

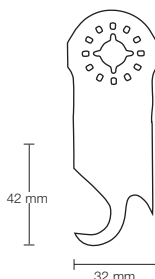

Corte rápido y preciso de material blando y material flexible abrasivo, p.e. alfombras, cartón, PVC...

Fast and precise cutting of soft material and abrasive flexible material, such as carpets, carton, PVC...

Coupe propre et précise sur bois tendres et matériaux flexibles abrasifs. Tapis, cartons, PVC.



SETS

STARLOCK

Ref. **2900**

SETS MULTI-FUNCIÓN

Oscillating Multi-Tool Sets
Jeux de outils multifonction

Ref. **2940-2910**

Ref. **2930**

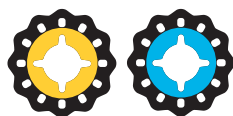

MADERA
Wood Bois
+ METAL

Cont.	Nº Art.	€
4 pcs:		
Ref. 2940:		
Mod. 00030	69702	115,74
Ref. 2910:		
Mods. 00020-00060-00070		



ESPECIAL
Special
Spécial

Cont.	Nº Art.	€
4 pcs:		
Ref. 2930:		
Mods. 00020-00060-00070-00080	69704	155,72



Línea 1m
2900

OSCILANTES MULTI-FUNCIÓN

Oscillating Multi-Tools
Outils multifonction



25 cm

Ref.	2910	2910	2910	2910	2930	2930	2940	2940	2940
	00030	00050	00070	00080	00080	00110	00020	00030	00070
Pcs	3	3	3	3	3	3	3	3	3

Ref. 4995 - Nº Art. 72189: **627,54 €**

Display
53

OSCILANTES MULTI-FUNCIÓN

Oscillating Multi-Tools
Outils multifonction



Ref. 2940			
ø	Mod. 00020	Mod. 00030	Mod. 00070
Pcs	3	3	3
Ref. 2910			
ø	Mod. 00030	Mod. 00050	Mod. 00070
Pcs	3	3	3
Ref. 2910		Ref. 2930	
ø	Mod. 00080	Mod. 00080	Mod. 00110
Pcs	3	3	3

Ref. 4995 - Nº Art. 69451: **627,54 €**

Mod **00010****CORTE RECTO MADERAS BLANDAS**Soft Wood Straight Cutting
Coupe droite bois tendre

Mod.		Nº	€
		Art.	Pack
00010	5	69140	52,63

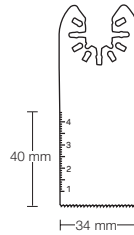
**HCS****Dentado estándar. Corte en madera y plástico.**

Standard teeth for wood and plastics.

Denture estándar. Coupe en bois et plastique.

Mod **00020****CORTE RECTO MADERAS DURAS**Hard Wood Straight Cutting
Coupe droite bois dur

Mod.		Nº	€
		Art.	Pack
00020	5	69141	76,36

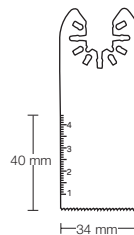
**Bimetal****Dentado ondulado universal. Corte en madera, plástico, pladur, metal y madera con clavos.**

Universal wave teeth for wood, plastics, drywall, metal and wood with nails.

Denture vague universelle. Coupe en bois, plastique, plâtre, métal et bois avec clous.

Mod **00030****CORTE RECTO ALTO RENDIMIENTO MADERAS DURAS**Hard Wood High Performance Straight Cutting
Coupe droite haut rendement bois dur

Mod.		Nº	€
		Art.	Pack
00030	5	69142	54,38

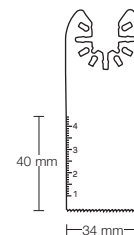
**Bimetal****Dentado japonés para corte en madera, contrachapado, plástico y otros materiales blandos.**

Japanese teeth for wood, plywood, plastics and other soft materials.

Denture japonaise pour coupe en bois, tole fine metal, plastiques et autres bois tendres.



Ref. **2950**

MULTI



QUICK-FIT



Mod **00040**

RASCADORA

Scraper
Racloir

Mod.	N° Art.	€ Pack
00040	5 69457	33,42

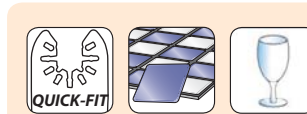
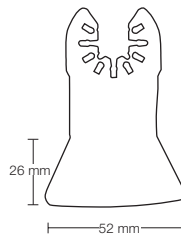

Rascador de silicona o similares en superficies lisas y delicadas como azulejos o cristal.
 Removing of silicone or caulking against a flat surface such as tile or glass that can be easily scratched.
 Racloir silicone où similaire pour surfaces lises et délicats comme carreaux où verre.

Ref. **2960**

MULTI



SUPERCUT



Mod **00010**

CORTE RECTO METAL / MADERA / CLAVOS

Straight Cutting in Metal / Wood / Nails
 Coupe droite dans Métal / Bois / Clous

Mod.	N° Art.	€ Pack
00010	5 69143	76,36

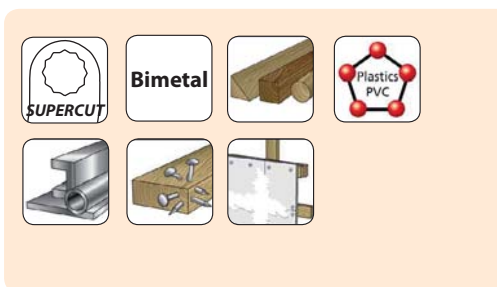
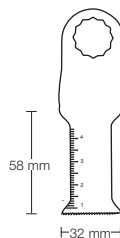

Dentado ondulado universal para madera, pladur, plástico, metal y madera con clavos. Mango acero inoxidable.
 Universal wave teeth for wood, drywall, plastics, metal and wood with nails. Stainless steel holder.
 Denture vague universelle pour bois, plâtre, plastique, métal et bois avec clous. Queue en acier inoxydable.



Mod **00020**

CORTE RECTO METAL / MADERA / CLAVOS

Straight Cutting in Metal / Wood / Nails
 Coupe droite dans Métal / Bois / Clous

Mod.	N° Art.	€ Pack
00020	5 69144	79,01

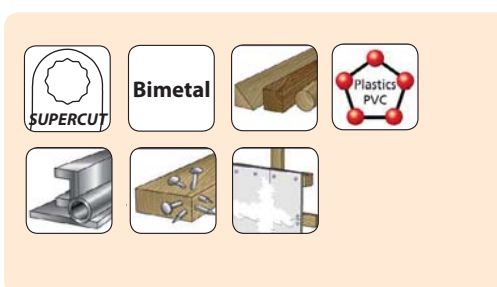
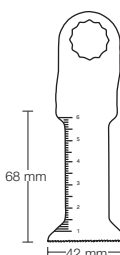

Dentado ondulado universal para madera, pladur, plástico, metal y madera con clavos. Mango acero inoxidable.
 Universal wave teeth for wood, drywall, plastics, metal and wood with nails. Stainless steel holder.
 Denture vague universelle pour bois, plâtre, plastique, métal et bois avec clous. Queue en acier inoxydable.

CUADRO USO SIERRAS SABLE

Sabre Blade Use Table

Tableau utilisation lames scies sabre

					MADERA Wood - Bois				PLÁSTICOS Plastics - Plastiques			METAL			
<ul style="list-style-type: none"> ● Ideal Ideal - Idéal ○ Adecuado Suitable - Convenable 					Todos tipos All types Toutes sortes		Dura Hard Dur	Pallet Palet Palette	Marcos ventana Window frames Fenêtres	Con clavos With nails Avec clous	Viva Green Vert	Plásticos Plastics Plastiques	Reforzados fibra-carbon Carbon-fibre reinforced Renforcés fibre-carbone	Plexiglass Perspex	INOX Stainless
	Ref. - Mod.	Equiv.	Mat.	l mm											
Madera Wood - Bois	1950 00010	S1617K	HCS/CV	280	●	○				●					
		00020	S644D	HCS/CV	130	●	○				●				
		00030	S1531L	HCS/CV	220										
		00210	S2345X	HCS/CV	220	●	○				●		●		
		00220	S611VF	Bi-metal	130	●	○		●						
		00230	S1111VF	Bi-metal	205	●	○		●						
Metal Metal - Métal		1920 00020	S922EF	Bi-metal	130									●	
			00030	S922BF	Bi-metal	130								●	
			00050	S1025VF	Bi-metal	180		●		●					
			00200	S1122EF	Bi-metal	180								●	
			00210	S1122BF	Bi-metal	180								●	
			00220	S922HF	Bi-metal	130								●	
			00230	S1122HF	Bi-metal	180								●	
			00240	S1211HF	Bi-metal	260								●	
			00250		Bi-metal	130				●					
			00260		Bi-metal	205				●					
			00270	S1120CF	Bi-metal	205				●				●	
			00280		Bi-metal	280				●				●	
			00290	S518EHM	CV-HM	95						●	●	●	
Especial Special		1960 00020	S922VF	Bi-metal	130	●	○	●		●					
			00030	S1122VF	Bi-metal	205	●	○	●						
			00040	S611DF	Bi-metal	130	●	○			●				
			00060	S1411DF	Bi-metal	280	●	○			●				
			00200	S1141HM	CV-HM	205	○	●				●			
			00210	S1241HM	CV-HM	280	○	●				●			
			00220	S1211K	INOX	280	●	○							
			00240	S1213AWP		280									
			00250	S1111DF	Bi-metal	205	●	○			●				
			00260	S1243HM	CV-HM	305									
		00270	S2243HM	CV-HM	455										

CUADRO USO SIERRAS SABLE

Sabre Blade Use Table

Tableau utilisation lames scies sabre

METAL

OTROS

Miscellaneous - Diverse

Corte
Cut - Coupe

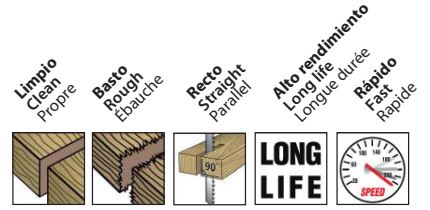
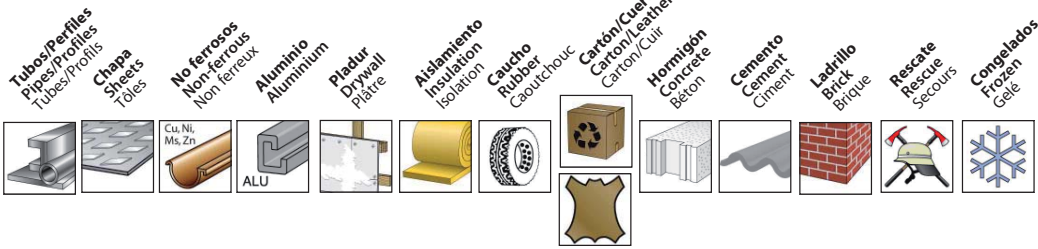

SIERRAS SABLE

Sabre Saw Blades

Lames scie sabre

Ref. **1950**

MADERA Wood Bois

Mod **00010**

CORTE BASTO

Rough Cut
Coupe grosse



S1617K



Dentado alterno y afilado diagonal. Corte basto para madera en general y madera viva.

Side set and diagonally sharpened toothing. Rough cutting of wood and green wood.

Denture avoyée, dépouillée et affûtée. Coupe grosse dans différents types de bois et bois verts.

Mod.	TPI	Diente Tooth mm	Dent mm	L mm	I mm	№ Art.	€ pack
00010	3	8,5	8,5	300	280	5 18870	21,97

Mod **00020**

CORTE RÁPIDO RECTO

Straight Fast Cut
Coupe rapide droite



S644D



Dentado alterno y afilado diagonal. Corte rápido y recto en todo tipo de maderas, plásticos y pladur.

Side set and diagonally sharpened toothing. Fast and straight cutting for all wood types, plastics and drywall.

Denture avoyée, dépouillée et affûtée. Coupe rapide et droite dans différents types de bois, plastiques et plâtres.

Mod.	TPI	Diente Tooth mm	Dent mm	L mm	I mm	№ Art.	€ pack
00020	6	4,2	4,2	150	130	5 18871	14,64

Mod **00030**

MADERA VIVA

Green Wood
Bois verts



S1531L



TPI
4-5



Dentado alterno reforzado por inducción con afilado diagonal. Especial madera viva.

Side set and diagonally sharpened induction hardened tooting. Special for green wood.

Denture avoyée, dépouillée, affûtée et traitée inductive-ment. Spécial pour bois verts.

Mod.	TPI	Diente Tooth Dent mm	L mm	I mm		Nº Art.	€ pack
00030	4-5	6,35-5	300	280	5	18872	23,24

Mod **00210**

CORTE LIMPIO

Clean Cut
Coupe propre



S2345X



TPI
6



Plastics
PVC



Dentado afilado triple. Corte limpio en todo tipo de maderas y plásticos.

Triply sharpened tooting. Clean cutting of all types of wood and plastics.

Denture triple dépouillée et affûtée. Coupe propre dans différents types de bois et plastiques.

Mod.	TPI	Diente Tooth Dent mm	L mm	I mm		Nº Art.	€ pack
00210	6	4,2	240	220	5	69001	23,43

Mod **00220**

CORTE RECTO ANCHO ESPECIAL

Special Thick Straight Cut
Coupe droite très grosse



S611VF



Dentado alterno y variable. Ancho de sierra especial para corte recto en todo tipo de maderas con residuos de metales.

Side set and variable toothing. Special thick blade for straight cutting of all wood types with few metal residues.

Denture fraisée, affûtée et variable. Lame très grosse pour coupe droite dans différents types de bois.

Mod.	TPI	Diente Tooth Dent mm	L mm	I mm	Nº Art.	€ pack
00220	5,8	5-3,2	150	130	5 69002	21,94

Mod **00230**

CORTE RECTO LARGO ANCHO ESPECIAL

Special Thick Long Straight Cut
Coupe droite longue très grosse



S1111VF

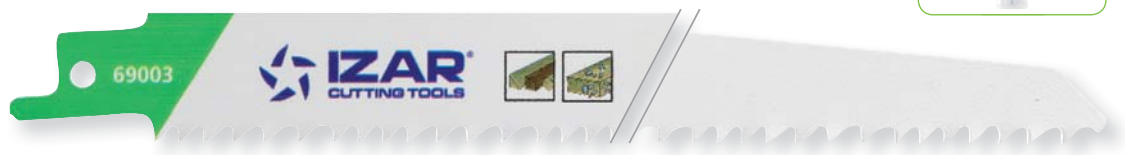

Dentado alterno y variable. Ancho de sierra especial para corte recto en todo tipo de maderas con residuos de metales.

Side set and variable toothing. Special thick blade for straight cutting of all wood types with few metal residues.

Denture fraisée, affûtée et variable. Lame très grosse pour coupe droite dans différents types de bois.

Mod.	TPI	Diente Tooth Dent mm	L mm	I mm	Nº Art.	€ pack
00230	5-8	5-3,2	225	205	5 69003	29,25

Mod **00020**

UNIVERSAL CORTE FLEXIBLE

Universal Flexible Cut
Universel coupe flexible



S922EF



Dentado fresado y ondulado. Sierra flexible y universal para aceros e inoxidables.

Milled teeth and wavy set. Flexible and universal blade for steel and stainless steel.

Dents fraisés et ondulés. Lame flexible et universel pour aciers et Inox.

Mod.	TPI	Diente Tooth Dent mm	L mm	I mm		Nº Art.	€ pack
00020	18	1,4	150	130	5	18865	15,50

Mod **00200**

UNIVERSAL CORTE FLEXIBLE LARGO

Universal Long Flexible Cut
Universel coupe flexible longue



S1122EF



Dentado fresado y ondulado. Sierra flexible y universal para aceros e inoxidables.

Milled teeth and wavy set. Flexible and universal blade for steel and stainless steel.

Dents fraisés et ondulés. Lame flexible et universelle pour aciers et Inox.

Mod.	TPI	Diente Tooth Dent mm	L mm	I mm		Nº Art.	€ pack
00200	18	1,4	200	180	5	69004	23,80

Mod **00030**

CORTE ACEROS, INOX, NO FERROSOS

Steel, Stainless, Non-Ferrous Cut
Coupe Aciers, Inox, Non ferreux



S922BF



			TPI 14	

Dentado fresado y ondulado. Sierra flexible y universal para aceros, inoxidables y metales no ferrosos.

Milled teeth and wavy set. Flexible and universal blade for steel, stainless steel and non-ferrous metals.

Dents fraisés et ondulés. Lame flexible et universelle pour aciers, Inox et métaux non ferreux.

Mod.	TPI	Diente Tooth Dent mm	L mm	I mm		Nº Art.	€ pack
00030	14	1,8	150	130	5	18866	17,22

Mod **00210**

CORTE LARGO ACEROS, INOX, NO FERROSOS

Steel, Stainless, Non-Ferrous Long Cut
Coupe longue Aciers, Inox, Non ferreux



S1122BF



			TPI 14	

Dentado fresado y ondulado. Sierra flexible y universal para aceros, inoxidables y metales no ferrosos.

Milled teeth and wavy set. Flexible and universal blade for steel, stainless steel and non-ferrous metals.

Dents fraisés et ondulés. Lame flexible et universelle pour aciers, Inox et métaux non ferreux.

Mod.	TPI	Diente Tooth Dent mm	L mm	I mm		Nº Art.	€ pack
00210	14	1,8	200	180	5	69005	22,67

Mod **00050**

CORTE RECTO ANCHO ESPECIAL PALLETS

Pallet Special Thick Straight Cut
Coupe droite très grosse palettes



S1025VF

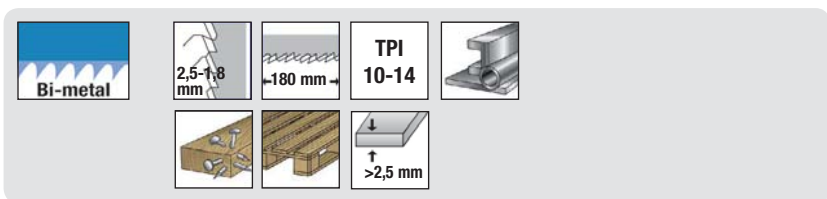

Dentado fresado, ondulado y variable. Ancho de sierra especial para corte recto en todo tipo de maderas con residuos de metales. Especial reparación de pallets.

Side set, wavy and variable toothing. Special thick blade for straight cutting of all wood types with few metal residues. Special for pallet repair.

Denture ondulé et variable. Lame très grosse pour coupe droite dans différents types de bois. Spécial pour réparation de palettes.

Mod.	TPI	Diente Tooth Dent mm	L mm	I mm	📦	Nº Art.	€ pack
00050	10-14	2,5-1,8	200	180	5	18868	26,18

Mod **00220**

CORTE ACEROS, INOX, NO FERROSOS

Steel, Stainless, Non-Ferrous Cut
Coupe Aciers, Inox, Non ferreux



S922HF

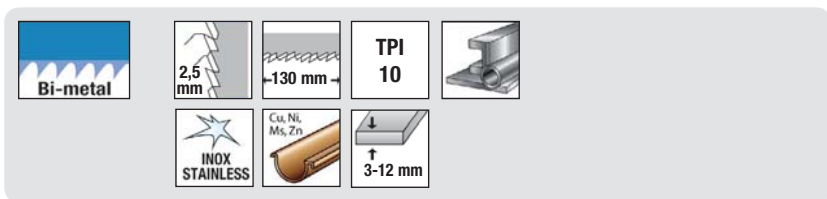

Dentado fresado y ondulado. Sierra flexible y universal para aceros, inoxidables y metales no ferrosos.

Milled teeth and wavy set. Flexible and universal blade for steel, stainless steel and non-ferrous metals.

Dents fraisés et ondulés. Lame flexible et universelle pour aciers, Inox et métaux non ferreux.

Mod.	TPI	Diente Tooth Dent mm	L mm	I mm	📦	Nº Art.	€ pack
00220	10	2,5	150	130	5	69006	18,15

Mod **00230**

CORTE LARGO ACEROS, INOX, NO FERROSOS

Steel, Stainless, Non-Ferrous Long Cut
Coupe Longue Aciers, Inox, Non ferreux



S1122HF

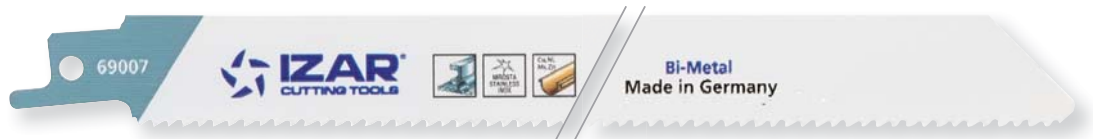

			TPI 10	

Dentado fresado y ondulado. Sierra flexible y universal para aceros, inoxidable y metales no ferrosos.

Milled teeth and wavy set. Flexible and universal blade for steel, stainless steel and non-ferrous metals.

Dents fraisés et ondulés. Lame flexible et universelle pour aciers, Inox et métaux non ferreux.

Mod.	TPI	Diente Tooth Dent mm	L mm	I mm		Nº Art.	€ pack
00230	10	2,5	200	180	5	69007	21,59

Mod **00240**

CORTE ACEROS, INOX, NO FERROSOS

Steel, Stainless, Non-Ferrous Cut
Coupe Aciers, Inox, Non ferreux



S1211HF



			TPI 10	

Dentado fresado y ondulado. Sierra flexible y universal para aceros, inoxidable y metales no ferrosos.

Milled teeth and wavy set. Flexible and universal blade for steel, stainless steel and non-ferrous metals.

Dents fraisés et ondulés. Lame flexible et universelle pour aciers, Inox et métaux non ferreux.

Mod.	TPI	Diente Tooth Dent mm	L mm	I mm		Nº Art.	€ pack
00240	10	2,5	280	260	5	69008	26,50

Mod **00250**

CORTE FLEXIBLE ALTO RENDIMIENTO

Long Life Flexible Cut
Coupe flexible longue durée

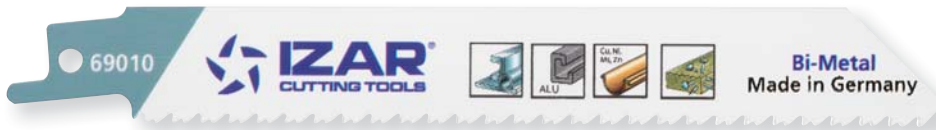

Dentado fresado y ondulado con geometría especial. Sierra flexible de alto rendimiento en metal y madera con residuos de metal.

Special geometry milled teeth and wavy set. High performance flexible blade for steel and wood with metal residues.

Dents fraisés et ondulés avec géométrie spéciale. Lame flexible, haut rendement dans aciers et bois.

Mod.	TPI	Diente Tooth Dent mm	L mm	I mm	Icon	Nº Art.	€ pack
00250	10-14	2,5-1,8	150	130	5	69010	19,35

* Hasta fin de existencias
while stock lasts / jusqu'à la fin de stock

Mod **00260**

CORTE FLEXIBLE LARGO ALTO RENDIMIENTO

Long Life Long Flexible Cut
Coupe flexible longue longue durée



S123XF



Dentado fresado y ondulado con geometría especial. Sierra flexible de alto rendimiento en metal y madera con residuos de metal.

Special geometry milled teeth and wavy set. High performance flexible blade for steel and wood with metal residues.

Dents fraisés et ondulés avec géométrie spéciale. Lame flexible, haut rendement dans aciers et bois.

Mod.	TPI	Diente Tooth Dent mm	L mm	I mm	Icon	Nº Art.	€ pack
00260	10-14	2,5-1,8	225	205	5	69011	27,02

Mod **00280**

RESCATE Y DESMONTAJE CORTE LARGO

Long Cut Rescue & Dismantling
Secours et démontage coupe longue

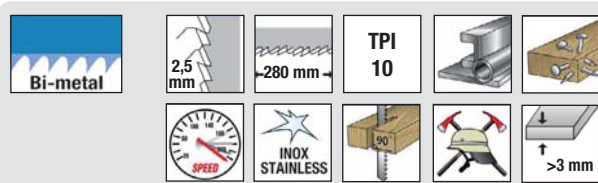
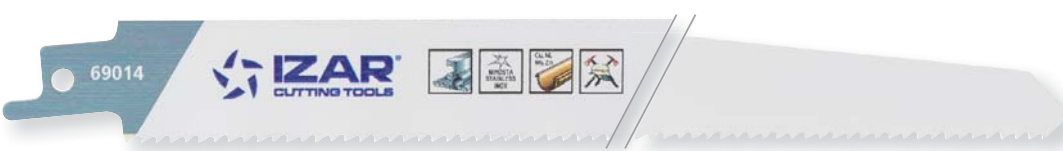

Dentado fresado y alterno. Sierra robusta con ancho especial para corte recto y rápido en acero, todo tipo de maderas con residuos de metal. Especial rescate y desmontaje.

Milled and side set teeth. Special thick and robust blade for fast and straight cutting of steel and all types of wood with metal residues. Especial for rescue and dismantling.

Dents fraisés et ondulés. Lame très épaisse pour coupe droite et rapide dans aciers et différents types de bois. Spéciale pour secours et démontages.

Mod.	TPI	Diente Tooth Dent mm	L mm	I mm	Icon	Nº Art.	€ pack
00280	10	2,5	300	280	5	69014	55,52

Mod **00020**

REPARACIÓN PALLETS

Pallet Repair
Réparation de palettes



S922VF

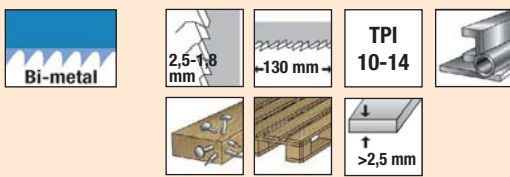

Dentado fresado, ondulado y variable. Todo tipo de maderas con residuos de metales. Especial reparación de pallets.

Side set, wavy and variable tooththing. All wood types with metal residues. Special for pallet repair.

Denture fraisée, ondulé et variable. Différents types de bois. Spéciale pour réparation de palettes.

Mod.	TPI	Diente Tooth Dent mm	L mm	I mm	Nº Art.	€ pack
00020	10-14	2,5-1,8	150	130	5 18874	18,91

Mod **00030**

REPARACIÓN PALLETS CORTE LARGO

Long Cut Pallet Repair
Réparation de palettes coupe longue



S1122VF

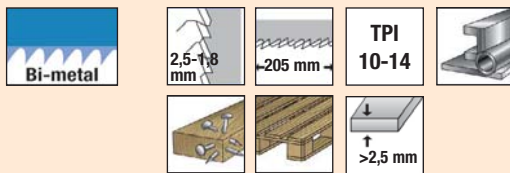

Dentado fresado, ondulado y variable. Todo tipo de maderas con residuos de metales. Especial reparación de pallets.

Side set, wavy and variable tooththing. All wood types with metal residues. Special for pallet repair.

Denture fraisée, ondulé et variable. Différents types de bois. Spéciale pour réparation de palettes.

Mod.	TPI	Diente Tooth Dent mm	L mm	I mm	Nº Art.	€ pack
00030	10-14	2,5-1,8	225	205	5 18875	23,57

Mod **00040**

CORTE FLEXIBLE RECTO RÁPIDO ALTO RENDIMIENTO

Long Life Fast Straight Flexible Cut
Coupe flexible droite rapide longue durée



Bi-metal 4,2 mm 130 mm TPI 6 Plastics PVC S611DF

Dentado fresado y alterno. Sierra flexible para corte recto y rápido en todo tipo de maderas y plásticos. Alto rendimiento.

Side set, milled teeth. Flexible blade for fast and straight cutting of all types of woods and plastics. Long lifetime.
Denture fraisée et avoyée. Lame flexible pour coupe droite et rapide dans différents types de bois et plastiques. Durée de vie plus longue.

Mod.	TPI	Diente Tooth Dent mm	L mm	I mm	№ Art.	€ pack
00040	6	4,2	150	130	5 18876	18,62

Mod **00060**

CORTE EXTRA LARGO FLEXIBLE RECTO RÁPIDO ALTO RENDIMIENTO

Long Life Fast Straight Flexible Extra Long Cut
Coupe extra longue flexible droite rapide longue durée



Bi-metal 4,2 mm 280 mm TPI 6 Plastics PVC S1411DF

Dentado fresado y alterno. Sierra flexible para corte recto y rápido en todo tipo de maderas y plásticos. Alto rendimiento.

Side set, milled teeth. Flexible blade for fast and straight cutting of all types of woods and plastics. Long lifetime.
Denture fraisée et avoyée. Lame flexible pour coupe droite et rapide dans différents types de bois et plastiques. Durée de vie plus longue.

Mod.	TPI	Diente Tooth Dent mm	L mm	I mm	№ Art.	€ pack
00060	6	4,2	300	280	5 18878	30,66

Mod **00200**

DENTADO TUNGSTENO

Tungsten Teeth
Denture Tungstène



S1141HM

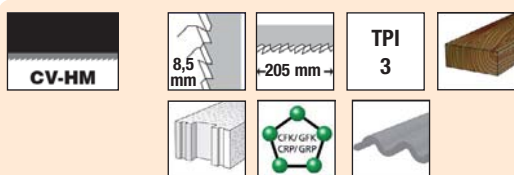

Dentado de tungsteno. Especial madera dura, hormigón poroso y productos reforzados con fibra de vidrio.

Side set, milled teeth. Special for hard wood, gas-formed concrete and glass-fibre reinforced products.

Denture fraisée et avoyée. Spéciale pour bois durs, bétons et matières plastiques renforcées avec fibres de verre.

Mod.	TPI	Diente Tooth Dent mm	L mm	I mm		Nº Art.	€ pack
00200	3	8,5	225	205	1	69017	37,03

Mod **00210**

DENTADO TUNGSTENO CORTE LARGO

Long Cut Tungsten Teeth
Denture Tungstène coupe longue



S1241HM

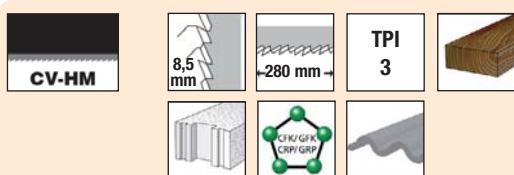

Dentado de tungsteno. Especial madera dura, hormigón poroso y productos reforzados con fibra de vidrio.

Side set, milled teeth. Special for hard wood, gas-formed concrete and glass-fibre reinforced products.

Denture fraisée et avoyée. Spéciale pour bois durs, bétons et matières plastiques renforcées avec fibres de verre.

Mod.	TPI	Diente Tooth Dent mm	L mm	I mm		Nº Art.	€ pack
00210	3	8,5	300	280	1	69019	43,13

Mod **00260**

DEMOLICIÓN CORTE LARGO TCT

TCT Long Cut Demolition
Démolition coupe longue TCT



S1243HM

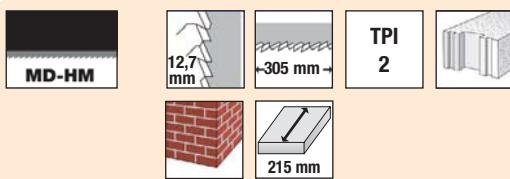

Dentado de tungsteno. Especial bloques de hormigón poroso, ladrillo, fibrocemento.

Tungsten teeth. Special for aerated concrete blocks, brick, fibre cement.

Denture Tungstène. Spécial pour blocs de béton cellulaire, brique, amiante-ciment.

Mod.	TPI	Diente Tooth Dent mm	L mm	I mm		Nº Art.	€ pack
00260	2	12,7	305	250	1	72626	41,87

Mod **00270**

DEMOLICIÓN CORTE EXTRA LARGO TCT

TCT Extra Long Cut Demolition
Démolition coupe extra longue TCT



S2243HM

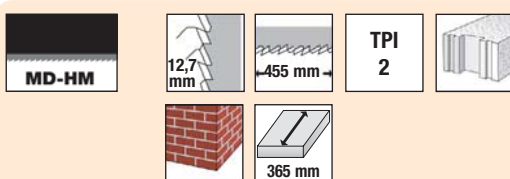

Dentado de tungsteno. Especial bloques de hormigón poroso, ladrillo, fibrocemento.

Tungsten teeth. Special for aerated concrete blocks, brick, fibre cement.

Denture Tungstène. Spécial pour blocs de béton cellulaire, brique, amiante-ciment.

Mod.	TPI	Diente Tooth Dent mm	L mm	I mm		Nº Art.	€ pack
00270	2	12,7	455	400	1	72627	51,15

Mod **00220**

HIELO Y COMIDA CONGELADA

Ice & Frozen Food
Glaces et produits surgelés



S1211K

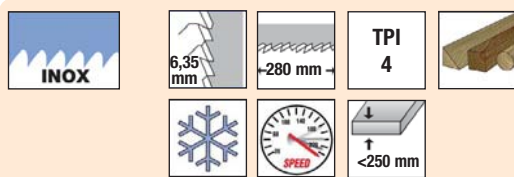

Dentado fresado y alterno de acero inoxidable. Especial comida congelada, hielo y madera.

Side set, milled teeth. Special for frozen food, ice and wood.

Denture fraisée et avoyée. Spéciale pour produits surgelés, glaces et bois.

Mod.	TPI	Diente Tooth Dent mm	L mm	I mm		Nº Art.	€ pack
00220	4	6,35	300	280	1	69020	20,04

Mod **00240**

CORTE RÁPIDO MUY LIMPIO AISLAMIENTO

Insulation Very Clean Fast Cut
Coupe rapide très propre isolant



S1213AWP



Dentado ondulado doble. Corte rápido y muy limpio en lana de roca, espuma, poliestireno, cuero, caucho, papel, cartón, alfombra.

Side set, milled teeth. Fast and very clean cutting of mineral rock wool, foam, polystyrene, rubber, paper, carton, carpet.

Denture fraisée et avoyée. Coupe rapide et très précise dans mousses, polystyrène, cuirs, caoutchouc, papiers, cartons, tapis.

Mod.	L mm	I mm		Nº Art.	€ pack
00240	300	280	5	69024	41,25

Mod **00300**

MANGO MULTIHERRAMIENTA

Multi Tool Handle
Queue multi-outils



HCS / CV

Espuma / Poliestireno
Foam / Polystyrene
Mousse / Polystyrène



MANGO MULTIHERRAMIENTA 2 en 1: atornillar y serrar

- Mango inclinable, facilita la transmisión de la fuerza
- Para lugares de difícil acceso
- Apto para sierras de sable y puntas de atornillar estándar
- Depósito para 6 puntas de atornillas (no incluidas)
- Fácil cambio de herramienta gracias a su anillo de montaje giratorio.
- Apto para uso manual en madera con Ref. 1950 mod. 00020, en metal con Ref. 1920 mod. 00200, en aislamiento y otros materiales con Ref. 1960 mod. 00240 y mod. 00280.

MULTITOOL HANDLE 2 in 1: screw and saw

- Inclinable handle for better power transmission
- Useful at places which are difficult to Access/reach
- Suitable for reciprocating saw blades and standard screw bits
- Bit magazine for 6 bits (not included)
- Easy tool change by means of a/its rotating mounting ring
- Suitable for manual use in wood with Ref. 1950 mod. 00020, in metal with Ref. 1920 mod. 00200 and in insulation and other materials with Ref. 1960 mod. 00240 and mod. 00280.

QUEUE MULTI-OUTILS 2 en 1: viser et serrer

- Queue réclinable: il rend plus facile la transmission des forces
- Pour des endroits de difficile accès
- Convenable pour scies sabres et embouts standards
- Capacité 6 embouts (pas compris)
- Changement d'outil facile grace à sa bague de montage rotative
- Conseillé pour utilisation à main en bois avec ref. 1950 mod. 00020, en métal avec ref. 1920 mod. 00200, en isolation et autres matériaux avec mod. 00240 et mod. 00280.

Mod.	Cont.		Nº Art.	€ pack
00300	1 x Mango / Handle / Queue 1 x Ref. 1960 - 00240 (Art. 69024) l=280 S1213AWP 1 x Ref. 1960 - 00280 (Art. 76688) l=205 S1113AWP	1	72851	43,63

Línea 1m
19SS

SIERRAS SABLE

Sabre Saw Blades
Lames scie sabre



Ref.	1920	1920	1920	1950	1950	1950	1960	1960	1960	1960
	00020	00030	00050	00010	00020	00030	00020	00030	00040	00060
Pcs	3	3	3	3	3	3	3	3	3	3

Ref. 4995 - Nº Art. 72191: 631,51 €

CUADRO USO SIERRAS CALAR

Jig Saw Blade Use Table

Tableau utilisation lames scies sauteuses

					MADERA - Wood - Bois								PLÁSTICOS				
<ul style="list-style-type: none"> ● Ideal Ideal - Idéal ○ Adecuado Suitable - Convenable 					Todos tipos All types Toutes sortes		Aglomerado laminado Laminated chipboard Panneau revêtu		Blanda Soft Tendre	Dura Hard Dur	Contrachapado Plywood Contreplaqué	Parquet laminado Laminated parquet Parquet lamifié		Con clavos With nails Avec clous	Aglomerado Chipboard Panneau	Plásticos Plastics Plastiques	Reforzados fibra-carbon Carbon-fibre Reinforced fibres-carbone

Madera
Wood - Bois

Ref. - Mod.	Equiv.	Mat.	I mm												
1940 00010	T119B	HCS/CV	50												
00020	T119BO	HCS/CV	50												
00030	T111C	HCS/CV	75												
00040	T144D	HCS/CV	75	●											
00050	T244D	HCS/CV	75	●											
00060	T101B	HCS/CV	75	●											
00070	T101BR	HCS/CV	75	●											
00080	T101D	HCS/CV	75	●											
00090	T301CD	HCS/CV	105	●											
00100		HCS/CV	75		●										
00110	T144DF	Bi-metal	75	●											
00130	T344D	HCS/CV	105	●											
00140	T234X	Bi-metal	91	●											
00150	T345XF	Bi-metal	105	○											
00160		HCS/CV	75	●											
00170	T308BCP	HCS/CV	105		●										
00180	T301B	HCS/CV	91	●											
00200	T744D	HCS/CV	155	●											

Metal
Metal - Métal

1910 00020	T118A	HSS	55												
00040	T318A	HSS	105												
00050	T118B	HSS	55												
00060	T318B	HSS	105												
00070	T118AF	Bi-metal	55												
00090	T118BF	Bi-metal	55												
00100	T318BF	Bi-metal	105												
00110	T127D	HSS	75												
00120	T118AHM	CV-HM	50												
00200	T718AF	Bi-metal	155												

Especial
Special

1930 00020	T127DF	Bi-metal	75												
00030	T130RIFF	CV-HM	54												
00200	T341HM	CV-HM	105												

Madera
Wood - Bois

1945 00030	U111C	HCS/CV	75												
00040	U144D	HCS/CV	75	●											
00060	U101B	HCS/CV	75	●											
00070	U101BR	HCS/CV	75	●											

Metal
Metal

1915 00020	U118A	HSS	55												
00070	U118AF	Bi-metal	55												
00110	U127D	Bi-metal	75												

SIERRAS CALAR

Jig Saw Blades

Lames scies sauteuses

Ref. **1940**

MADERA Wood Bois

Mod **010**

BÁSICA CORTE RECTO

Basic Straight Cut
Basiqye coupe droite

T119B



**NEW
PACKAGING!**

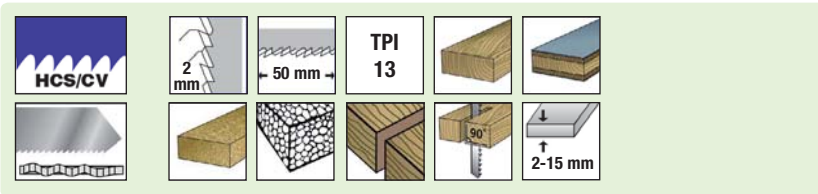

Dentado fresado y ondulado. Corte recto y limpio en madera blanda, madera contrachapada, tabla de viruta prensada, madera estratificada, tablero de fibra y materiales de aislamiento.

Milled teeth and wavy set. Straight and clean cutting of soft wood, plywood, chipboard, wood core plywood, fibre board and insulation materials.

Dents fraisés et ondulés. Coupe droite et propre dans bois tendres, contre-plaqué, agglomérés, fibres et matériaux d'isolation.

Mod.	TPI	Diente		L	I		Nº	€
		Tooth	Dent	mm	mm		Art.	pack
		mm	mm					
010	13	2		76	50	3	14129	2,49

Mod **020**

BÁSICA CORTE CURVO

Basic Curve Cut
Basiqye coupe courbe

T119BO



**NEW
PACKAGING!**

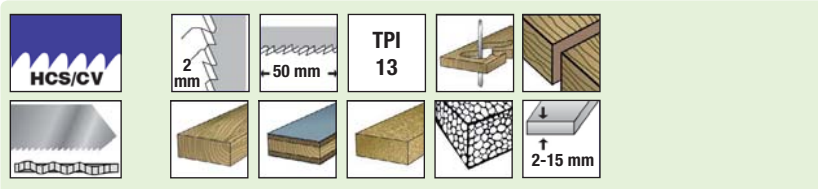

Dentado fresado y ondulado. Corte curvo y limpio en madera blanda, madera contrachapada, tabla de viruta prensada, madera estratificada, tablero de fibra y materiales de aislamiento.

Milled teeth and wavy set. Curve and clean cutting of soft wood, plywood, chipboard, wood core plywood, fibre board and insulation materials.

Dents fraisés et ondulés. Coupe courbe et propre dans bois tendres, contre-plaqué, agglomérés, fibres et matériaux d'isolation.

Mod.	TPI	Diente		L	I		Nº	€
		Tooth	Dent	mm	mm		Art.	pack
		mm	mm					
020	13	2		76	50	3	14138	3,55

Mod **030**

BÁSICA CORTE BASTO

Basic Rough Cut
Basique coupe gros

T111C



NEW PACKAGING!

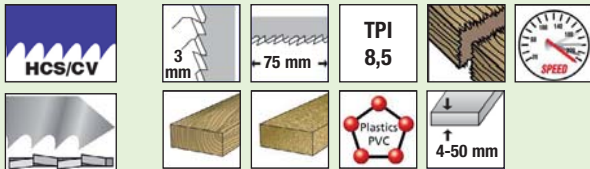

Dentado alterno. Corte basto y rápido en madera blanda, tabla de viruta prensada, madera estratificada, tablero de fibra y plástico.

Side set toothing. Rough and fast cutting of soft wood, chipboard, wood core plywood, fibre board and plastics.

Denture avoyée et affûtée. Coupe grosso et rapide dans bois tendres, agglomérés, fibres et plastiques.

Mod.	TPI	Diente Tooth Dent mm	L mm	I mm	📦	Nº Art.	€ pack
030	8,5	3	100	75	3	14221	2,57

Mod **040**

CORTE RÁPIDO

Fast Cut
Coupe rapide

T144D



NEW PACKAGING!



Dentado alterno y afilado diagonal. Corte rápido en todo tipo de maderas.

Side set and diagonally sharpened toothing. Fast cutting for all wood types.

Denture avoyée, dépouillée et affûtée. Coupe rapide dans différents types de bois.

Mod.	TPI	Diente Tooth Dent mm	L mm	I mm	📦	Nº Art.	€ pack
040	6,35	4	100	75	3	14230	3,74



Mod **050**

CORTE RÁPIDO CURVO

Curve Fast Cut
Coupe rapide courbe

T244D



NEW PACKAGING!

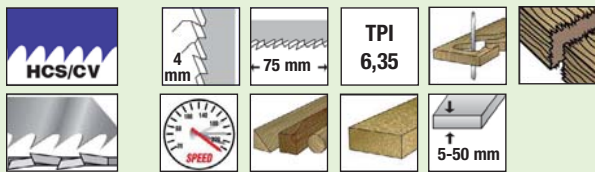

Dentado alterno y afilado diagonal. Corte rápido y curvo en todo tipo de maderas.

Side set and diagonally sharpened toothing. Fast and curve cutting for all wood types.

Denture avoyée, dépouillée et affûtée. Coupe rapide et courbe dans différents types de bois.

Mod.	TPI	Diente Tooth Dent mm	L mm	I mm	№ Art.	€ pack
050	6,35	4	100	75	3 14231	4,25

Mod **060**

CORTE LIMPIO

Clean Cut
Coupe propre

T101B



NEW PACKAGING!

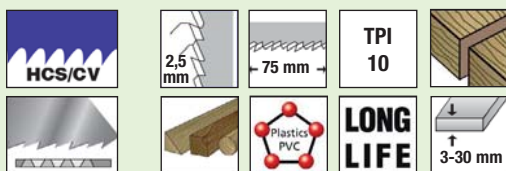

Sierra rectificadо cónico y dentado afilado diagonal. Corte limpio en todo tipo de maderas y plásticos.

Conically ground blade with diagonally sharpened teeth. Clean cutting for all wood types and plastics.

Corps de la lame conique et denture dépouillée et affûtée. Coupe propre dans différents types de bois et plastiques.

Mod.	TPI	Diente Tooth Dent mm	L mm	I mm	№ Art.	€ pack
060	10	2,5	100	75	3 14233	4,28



Mod **070**

CORTE LIMPIO SIN ASTILLAS

Splinterfree Clean Cut
Coupe propre sans éclat

T101BR



**NEW
PACKAGING!**

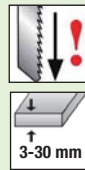

Sierra rectificado cónico y dentado afilado diagonal. Dentado inverso. Corte limpio sin astillas en todo tipo de maderas y plásticos.

Conically ground blade with diagonally sharpened teeth. Reverse teeth. Clean splinterfree cutting for all wood types and plastics.

Corps de la lame conique et denture dépouillée et affûtée. Denture inversée. Coupe propre sans éclats dans différents types de bois et plastiques.

Mod.	TPI	Diente Tooth Dent mm	L mm	I mm	3	Nº Art.	€ pack
070	10	2,5	100	75	3	14236	5,28

Mod **080**

CORTE LIMPIO RÁPIDO

Fast Clean Cut
Coupe propre rapide

T101D



**NEW
PACKAGING!**

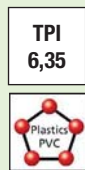
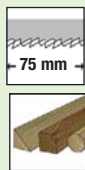
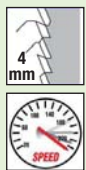

Sierra rectificado cónico y dentado afilado diagonal. Corte limpio y rápido en todo tipo de maderas y plásticos.

Conically ground blade with diagonally sharpened teeth. Clean and fast cutting for all wood types and plastics.

Corps de la lame conique et denture dépouillée et affûtée. Coupe propre et rapide dans différents types de bois et plastiques.

Mod.	TPI	Diente Tooth Dent mm	L mm	I mm	3	Nº Art.	€ pack
080	6,35	4	100	75	3	14243	4,28



Mod **100**

CORTE LIMPIO CURVO

Curve Clean Cut
Coupe propre courbe

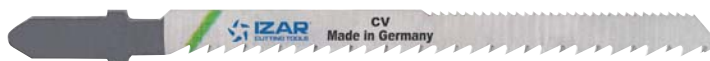

NEW PACKAGING!

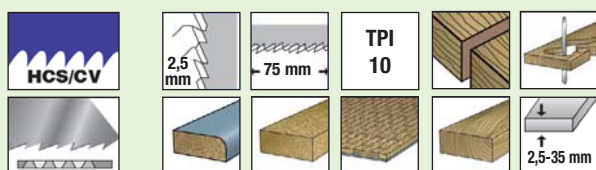

Sierra rectificado cónico y dentado afilado diagonal. Corte limpio y curvo en madera blanda, aglomerado, laminado, parqueté.

Conically ground blade with diagonally sharpened teeth. Clean and curve cutting for soft wood, chipboard, laminated board, parquett.

Corps de la lame conique et denture dépouillée et affûtée. Coupe propre et courbe dans bois tendres, agglomérés, panneaux en bois, parquets.

Mod.	TPI	Diente Tooth Dent mm	L mm	I mm		Nº Art.	€ pack
100	10	2,5	100	75	3	14302	5,88

Mod **090**

CORTE LIMPIO LARGO

Long Clean Cut
Coupe propre longue

NEW PACKAGING!



T301CD

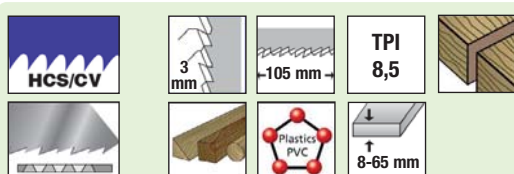

Sierra rectificado cónico y dentado afilado diagonal. Corte limpio y largo en todo tipo de maderas y plásticos.

Conically ground blade with diagonally sharpened teeth. Clean and long cutting for all wood types and plastics.

Corps de la lame conique et denture dépouillée et affûtée. Coupe propre et longue dans différents types de bois et plastiques.

Mod.	TPI	Diente Tooth Dent mm	L mm	I mm		Nº Art.	€ pack
090	8,5	3	132	105	3	14246	5,59



Mod

110

CORTE RÁPIDO ALTO RENDIMIENTO

Long Life Fast Cut
Coupe rapide longue durée

T144DF



NEW PACKAGING!



Dentado alterno y afilado diagonal. Corte rápido en todo tipo de maderas. Alto rendimiento.

Side set and diagonally sharpened toothing. Fast cutting for all wood types. Long lifetime.

Denture avoyée, dépouillée et affûtée. Coupe rapide dans différents types de bois. Durée de vie plus longue.

Mod.	TPI	Diente Tooth Dent mm	L mm	l mm		Nº Art.	€ pack
110	6,35	4	100	75	3	14306	7,43

Mod

130

CORTE RÁPIDO LARGO

Long Fast Cut
Coupe rapide longue

T344D



NEW PACKAGING!

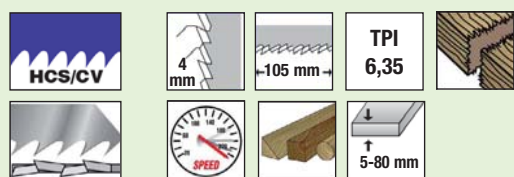

Dentado alterno y afilado diagonal. Corte rápido y largo en todo tipo de maderas.

Side set and diagonally sharpened toothing. Fast and long cutting for all wood types.

Denture avoyée, dépouillée et affûtée. Coupe rapide et longue dans différents types de bois.

Mod.	TPI	Diente Tooth Dent mm	L mm	l mm		Nº Art.	€ pack
130	6,35	4	132	105	3	14307	4,63



Mod **140**

CORTE LIMPIO RÁPIDO

Fast Clean Cut
Coupe propre rapide

NEW PACKAGING!



T234X

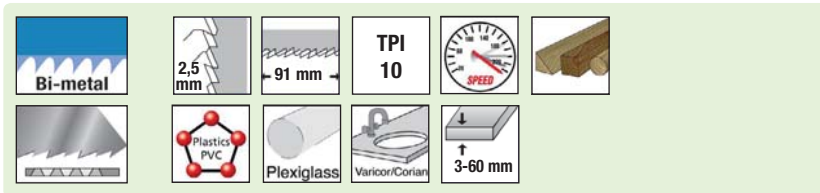

Sierra rectificado cónico y dentado afilado triple. Corte limpio y rápido en todo tipo de maderas y plásticos.

Conically ground blade with 3-times sharpened teeth. Clean and fast cutting for all wood types and plastics.

Corps de la lame conique avec denture affûtée triple. Coupe propre et rapide dans différents types de bois et plastiques.

Mod.	TPI	Diente Tooth Dent mm	L mm	I mm	Nº Art.	€ pack
140	10	2,5	117	91	3 14326	8,56

Mod **150**

CORTE LARGO FLEXIBLE ALTO RENDIMIENTO

Long Life Flexible Long Cut
Coupe longue flexible longue durée

NEW PACKAGING!



T345XF

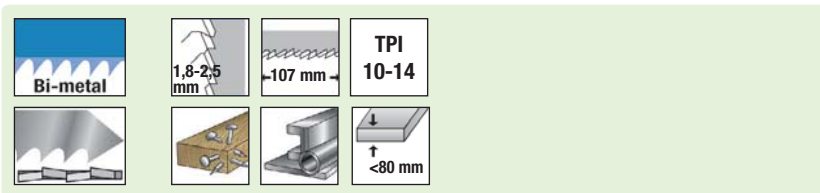

Dentado fresado alterno. Sierra larga y flexible para madera con residuos de metal, tubos y perfiles de acero (2,5-10 mm). Gran rendimiento.

Milled and side teeth. Long and flexible blade for wood with metal residues, steel pipes and profiles (2,5-10 mm). Long lifetime.

Dents fraisés et avoyés. Lame très longue et flexible pour bois avec métaux résiduels, tubes et profils en acier (2,5-10 mm). Durée de vie plus longue.

Mod.	TPI	Diente Tooth Dent mm	L mm	I mm	Nº Art.	€ pack
150	10-14	1,8-2,5	132	107	3 14327	10,47

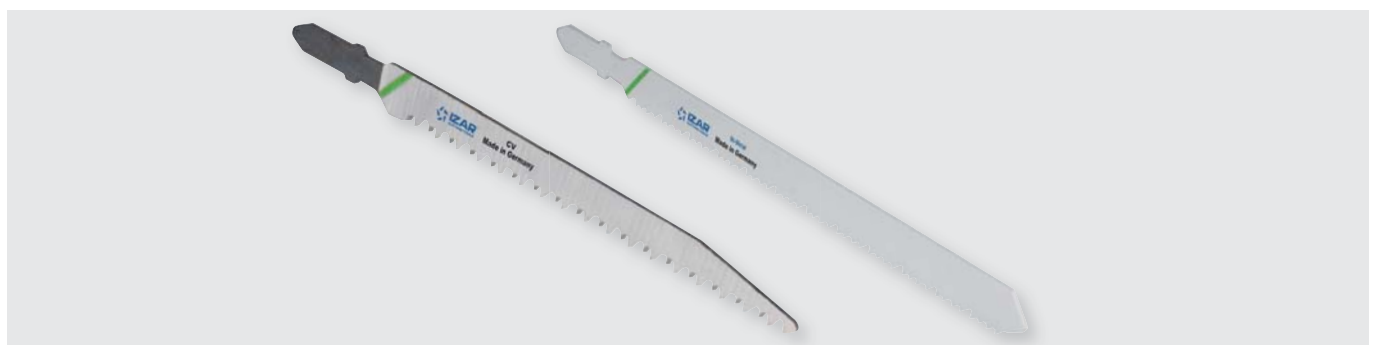

Mod

160

CORTE RÁPIDO CURVO

Curve Fast Cut
Coupe rapide courbe

NEW
PACKAGING!

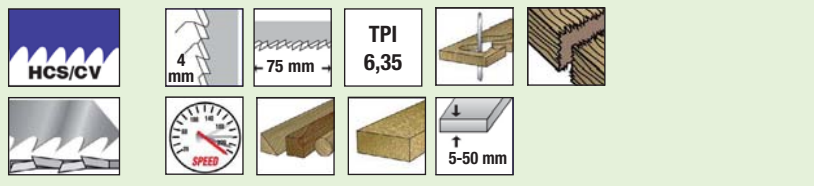

Dentado doble alterno y afilado diagonal. Corte rápido y curvo en todo tipo de maderas.

Double side set and diagonally sharpened toothing. Fast and curve cutting for all wood types.

Denture double avoyée, dépouillée et affûtée. Coupe rapide et courbe dans différents types de bois.

Mod.	TPI	Diente Tooth Dent mm	L mm	I mm	№ Art.	€ pack
160	6,35	4	100	75	3 14328	11,19

Mod

170

CORTE LIMPIO RÁPIDO

Fast Clean Cut
Coupe propre rapide

NEW
PACKAGING!



T308BCP

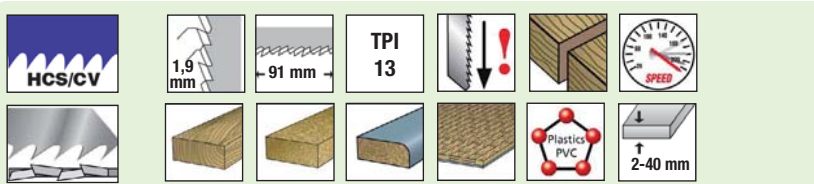

Sierra rectificación cónica y dentado afilado inverso. Corte limpio y rápido en madera blanda, aglomerado, tablero de fibra, laminado, parqué, laminado plástico.

Conically ground blade with reverse sharpened teeth. Clean and fast cutting for all wood types and plastics.

Corps de la lame conique denture renversée et affûtée. Coupe propre et rapide dans différents types de bois et plastiques.

Mod.	TPI	Diente Tooth Dent mm	L mm	I mm	№ Art.	€ pack
170	13	1,9	117	91	3 14331	4,62



Mod **180**

CORTE LIMPIO

Clean Cut
Coupe propre

**NEW
PACKAGING!**



T301B

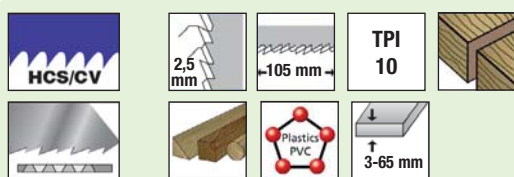

Sierra rectificado cónico y dentado afilado diagonal. Corte limpio en todo tipo de maderas y plásticos.

Conically ground blade with diagonally sharpened teeth. Clean cutting for all wood types and plastics.

Corps de la lame conique denture dépouillée et affûtée. Coupe propre dans différents types de bois et plastiques.

Mod.	TPI	Diente Tooth Dent mm	L mm	I mm	Nº Art.	€ pack
180	10	2,5	132	105	14332	7,73

Mod **200**

CORTE RÁPIDO MUY LARGO

Very Long Fast Cut
Coupe rapide très longue

**NEW
PACKAGING!**



T744D



Dentado alterno y afilado diagonal. Corte rápido y muy largo en todo tipo de maderas.

Side set and diagonally sharpened toothing. Fast and very long cutting for all wood types.

Denture avoyée, dépouillée et affûtée. Coupe rapide et très longue dans différents types de bois.

Mod.	TPI	Diente Tooth Dent mm	L mm	I mm	Nº Art.	€ pack
200	6,35	4	180	155	14334	8,30



Mod **020**

CORTE LÁMINAS FINAS ACERO

Thin Steel Sheet Cut
Coupe tôles fines acier

**NEW
PACKAGING!**



T118A

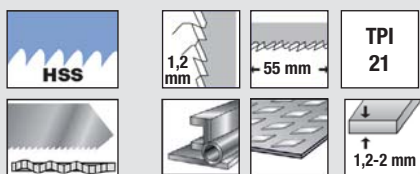

Dentado fresado y ondulado. Láminas finas de acero.
Milled teeth and wavy set. Thin steel sheets.
Dents fraisés et ondulés. Tôles fines.

Mod.	TPI	Diente Tooth Dent mm	L mm	I mm		Nº Art.	€ pack
020	21	1,2	76,5	55	3	14336	4,27

Mod **040**

CORTE LARGO LÁMINAS FINAS ACERO

Thin Steel Sheet Long Cut
Coupe longue tôles fines acier

**NEW
PACKAGING!**



T318A

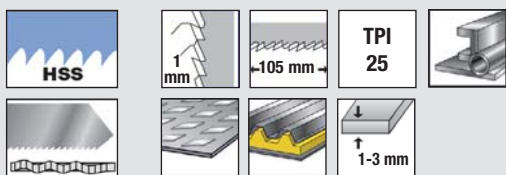

Dentado fresado y ondulado. Sierra larga para láminas finas de acero, tubos, perfiles y material tipo sandwich hasta 80 mm.

Milled teeth and wavy set. Long blade for thin steel sheets, pipes, profiles and sandwich-material up to 80 mm.
Dents fraisés et ondulés. Lame longue pour tôles fines, profils, tubes et matériel sandwich jusqu'à 80 mm.

Mod.	TPI	Diente Tooth Dent mm	L mm	I mm		Nº Art.	€ pack
040	25	1	132	105	3	14339	7,04



Mod **050**

CORTE ACEROS, NO FERROSOS, ALUMINIO

Steel, Non-Ferrous, Aluminium Cut
Coupe Aciers, Non ferreux, Aluminium

NEW PACKAGING!



T118B

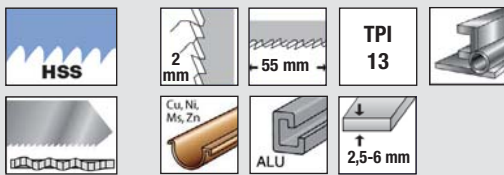

Dentado fresado y ondulado. Aceros, metales no ferrosos y aluminio.

Milled teeth and wavy set. Steel, non-ferrous metal and aluminium.

Dents fraisés et ondulés. Aciers, métaux non ferreux et aluminiums.

Mod.	TPI	Diente Tooth Dent mm	L mm	I mm	📦	Nº Art.	€ pack
050	13	2	76,5	55	3	14349	4,27

Mod **060**

CORTE LARGO FLEXIBLE

Flexible Long Cut
Coupe longue flexible

NEW PACKAGING!



T318B



Dentado fresado y ondulado. Sierra larga y flexible para aceros, tubos, perfiles, material tipo sandwich hasta 80 mm y metales no ferrosos. Alto rendimiento.

Milled teeth and wavy set. Long and flexible blade for steel, pipes, profiles, sandwich-material up to 80 mm and non-ferrous metals. Long life.

Dents fraisés et ondulés. Lame longue et flexible pour aciers, profils, tubes, matériel sandwich jusqu'à 80 mm et métal non ferreux. Durée de vie plus longue.

Mod.	TPI	Diente Tooth Dent mm	L mm	I mm	📦	Nº Art.	€ pack
060	14	1,8	132	105	3	14351	6,52



Mod **070**

CORTE FLEXIBLE ALTO RENDIMIENTO

Long Life Flexible Cut
Coupe flexible longue durée

**NEW
PACKAGING!**



T118AF

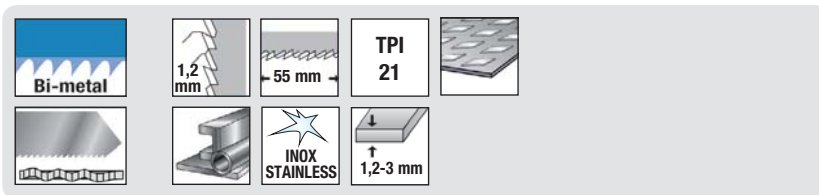

Dentado fresado y ondulado. Sierra flexible para aceros e inoxidables. Alto rendimiento.

Milled teeth and wavy set. Flexible blade for steel and stainless steel. Long life.

Dents fraisés et ondulés. Lame longue et flexible pour aciers et inoxydables. Durée de vie plus longue.

Mod.	TPI	Diente		L mm	l mm	Nº Art.	€ pack
		Tooth mm	Dent mm				
070	21	1,2	76,5	55	3	14352	5,55

Mod **090**

CORTE FLEXIBLE ALTO RENDIMIENTO

Long Life Flexible Cut
Coupe flexible longue durée

**NEW
PACKAGING!**



T118BF

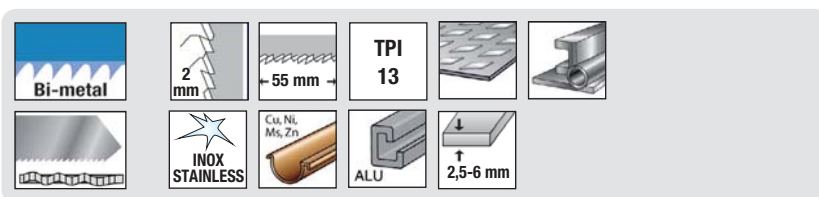

Dentado fresado y ondulado. Sierra flexible para aceros e inoxidables, metales no ferrosos y aluminio. Alto rendimiento.

Milled teeth and wavy set. Flexible blade for steel and stainless steel, non-ferrous metals and aluminium. Long life.

Dents fraisés et ondulés. Lame longue et flexible pour aciers et inoxydables, métaux non ferreux et aluminium. Durée de vie plus longue.

Mod.	TPI	Diente		L mm	l mm	Nº Art.	€ pack
		Tooth mm	Dent mm				
090	13	2	76,5	55	3	14353	5,55



Mod **100**

CORTE LARGO FLEXIBLE ALTO RENDIMIENTO

Long Life Flexible Long Cut
Coupe longue flexible longue durée

**NEW
PACKAGING!**



T318BF

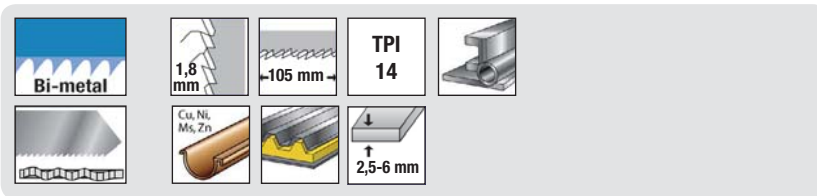

Dentado fresado y ondulado. Sierra larga y flexible para aceros, tubos, perfiles, material tipo sandwich hasta 80 mm y metales no ferrosos. Alto rendimiento.

Milled teeth and wavy set. Long and flexible blade for steel, pipes, profiles, sandwich-material up to 80 mm and non-ferrous metals. Long life.

Dents fraisés et ondulés. Lame longue et flexible pour aciers, profils, tubes, matériel sandwich jusqu'à 80 mm et métaux non ferreux. Durée de vie plus longue.

Mod.	TPI	Diente Tooth Dent mm	L mm	I mm	📦 Nº Art.	€ pack
100	14	1,8	132	105	3 14358	10,12

Mod **110**

CORTE ACEROS, NO FERROSOS, ALUMINIO, PLÁSTICO

Steel, Non-Ferrous, Aluminium, Plastic Cut
Coupe Aciers, Non ferreux, Aluminium, Plastique

**NEW
PACKAGING!**



T127D

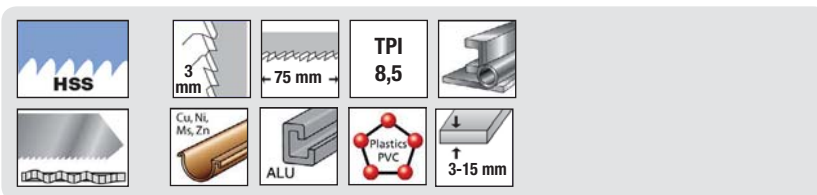

Dentado fresado alterno. Aceros, metales no ferrosos, aluminio y plásticos.

Milled teeth and side set. Steel, non-ferrous metals, aluminium and plastics.

Dents fraisés et avoyés. Aciers, métaux non ferreux, aluminiums et plastiques.

Mod.	TPI	Diente Tooth Dent mm	L mm	I mm	📦 Nº Art.	€ pack
110	8,5	3	100	75	3 14372	5,32



Mod **120**

METAL DURO PULVERIZADO

Grinded Carbide
Carbure pulvérisé

NEW PACKAGING!



T118AHM



CV-HM	1,1 mm	50 mm	TPI 23	
	INOX STAINLESS	1,5-3 mm		

Banda de metal duro pulverizado. Aceros, planchas de metal e inoxidables.

Grinded carbide strip. Steel, metal sheets and stainless steel.

Dents en carbure. Aciers, tôles et aciers inoxydables.

Mod.	TPI	Diente Tooth mm	Dent mm	L mm	I mm	Nº Art.	€ pack
120	23	1,1	79	50	1	14379	16,48

Mod **200**

CORTE LARGO FLEXIBLE CONSTRUCCIÓN ALTO RENDIMIENTO

Long Life Construction Flexible Long Cut
Coupe longue flexible construction longue durée

NEW PACKAGING!



T718AF



Bi-metal	2 mm	155 mm	TPI 12	
	INOX STAINLESS	2-120 mm		

Dentado fresado y ondulado. Sierra larga y flexible para construcción de fachadas y material tipo sandwich. Alto rendimiento.

Milled teeth and wavy set. Long and flexible blade for facade construction and sandwich-material. Long life.

Dents fraisés et ondulés. Lame longue et flexible pour les façades et matériel sandwich. Durée de vie plus longue

Mod.	TPI	Diente Tooth mm	L mm	I mm	Nº Art.	€ pack
200	12	2	180	155	3	14380 12,23



Mod **020**

CORTE FLEXIBLE METAL, PLÁSTICO

Plastic, Metal Flexible Cut
Coupe flexible Métal, Plastique

NEW PACKAGING!



T127DF

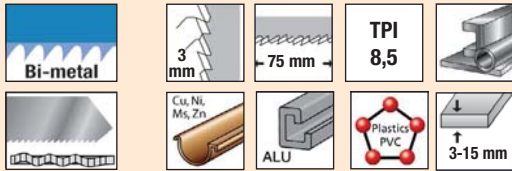

Dentado fresado alterno. Sierra flexible para aceros, metales no ferrosos, aluminio (3-15 mm) y plásticos (3-30 mm).

Milled teeth and side set. Flexible blade for steel, non-ferrous metals, aluminium (3-15 mm) and plastics (3-30 mm).

Dents fraisés et avoyés. Lame flexible pour aciers, métaux non ferreux, aluminiums (3-15 mm) et plastiques (3-30 mm).

Mod.	TPI	Diente		L mm	I mm	Nº Art.	€ pack
		Tooth mm	Dent mm				
020	8,5	3	3	100	75	3 14386	7,29

Mod **030**

CORTE VIDRIO, CERÁMICA

Ceramic, Glass Cut
Coupe Verre, Céramique

NEW PACKAGING!



T130RIFF

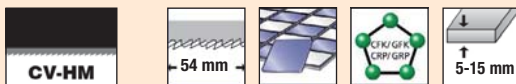

Recubrimiento de metal duro de grano grueso. Vidrio, cerámica y productos reforzados con fibra de vidrio.

Carbide coated, coarse-grained. Glass, ceramics, glass-fibre reinforced products.

Revêtement en carbure, gros grains. Verre, céramique, fibre de verre.

Mod.	L mm	I mm	Nº Art.	€ pack
030	79	54	1 14387	3,93

Mod **200**

DENTADO METAL DURO TUNGSTENO

Tungsten Carbide Teeth
Denture carbure Tungstène

NEW PACKAGING!



T341HM

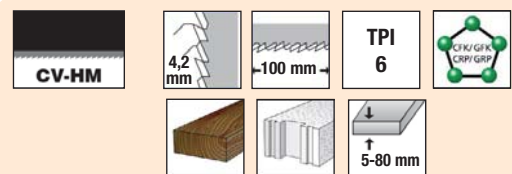

Dentado metal duro tungsteno. Fibra de vidrio, madera dura y hormigón gaseoso.

Carbide coated, coarse-grained. Glass-fibre, hard wood and gas formed concrete.

Revêtement en carbure, gros grains. Fibre de verre, bois durs et béton.

Mod.	TPI	Diente		L mm	I mm	Nº Art.	€ pack
		Tooth mm	Dent mm				
200	6	4,2	4,2	132	100	1 14390	11,43

Mod **00030**

BÁSICA CORTE BASTO RÁPIDO

Basic Fast Rough Cut
Basique coupe gros rapide



U111C

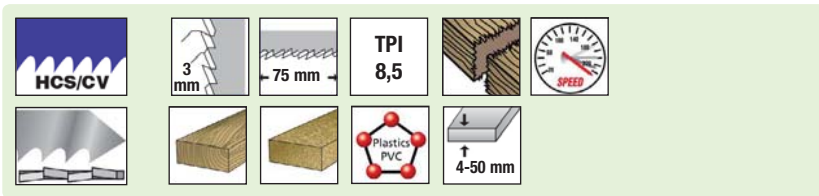

Dentado alterno. Corte basto y rápido en madera blanda, tabla de viruta prensada, madera estratificada, table-ro de fibra y plástico.

Side set toothing. Rough and fast cutting of soft wood, chipboard, wood core plywood, fibre board and plastics.

Denture avoyée et affûtée. Coupe grosse et rapide dans bois tendres, agglomérés, fibres et plastiques.

Mod.	TPI	Diente Tooth Dent mm	L mm	I mm		Nº Art.	€ pack
00030	8,5	3	100	75	5	21883	4,89

Mod **00040**

CORTE RÁPIDO

Fast Cut
Coupe rapide



U144D

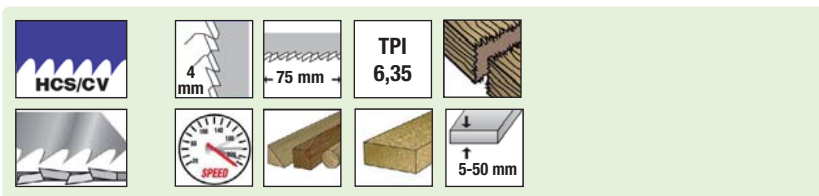

Dentado alterno y afilado diagonal. Corte rápido en todo tipo de maderas.

Side set and diagonally sharpened toothing. Fast cutting for all wood types.

Denture avoyée, dépouillée et affûtée. Coupe rapide dans différents types de bois.

Mod.	TPI	Diente Tooth Dent mm	L mm	I mm		Nº Art.	€ pack
00040	6,35	4	100	75	5	21884	6,80

Mod **00060**

CORTE LIMPIO

Clean Cut
Coupe propre



U101B

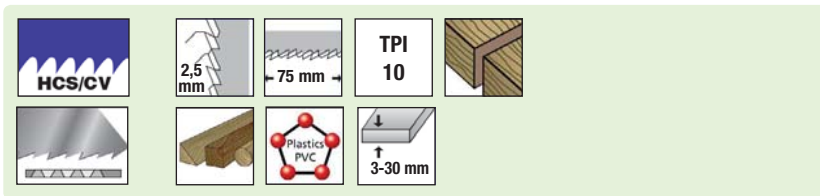

Sierra rectificado cónico y dentado afilado diagonal. Corte limpio en todo tipo de maderas y plásticos.

Conically ground blade with diagonally sharpened teeth. Clean cutting for all wood types and plastics.

Corps de la lame conique et denture dépouillée et affûtée. Coupe propre dans différents types de bois et plastiques.

Mod.	TPI	Diente Tooth Dent mm	L mm	I mm		Nº Art.	€ pack
00060	10	2,5	100	75	5	21885	8,03

Mod **00070**

CORTE LIMPIO SIN ASTILLAS

Splinterfree Clean Cut
Coupe propre sans éclat



U101BR

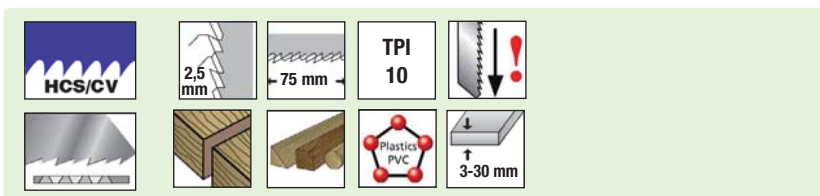

Sierra rectificado cónico y dentado afilado diagonal. Dentado inverso. Corte limpio sin astillas en todo tipo de maderas y plásticos.

Conically ground blade with diagonally sharpened teeth. Reverse teeth. Clean splinterfree cutting for all wood types and plastics.

Corps de la lame conique et denture dépouillée et affûtée. Denture inversée. Coupe propre sans éclats dans différents types de bois et plastiques.

Mod.	TPI	Diente Tooth Dent mm	L mm	I mm		Nº Art.	€ pack
00070	10	2,5	100	75	5	21886	8,03

Mod **00020**

CORTE LÁMINAS FINAS ACERO

Thin Steel Sheet Cut
Coupe tôles fines acier



U118A

21892

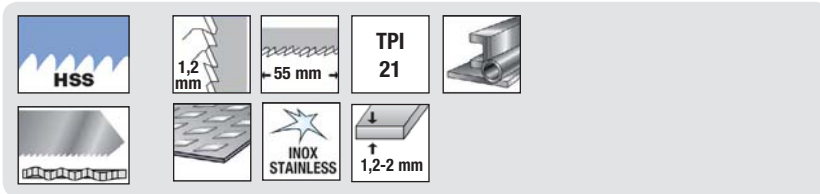
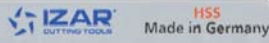

Dentado fresado y ondulado. Láminas finas de acero e inoxidable.

Milled teeth and wavy set. Thin steel and stainless steel sheets.

Dents fraisés et ondulés. Tôles fines en acier et inoxydable.

Mod.	TPI	Diente Tooth Dent mm	L mm	I mm		Nº Art.	€ pack
00020	21	1,2	76,5	55	5	21892	8,13

Mod **00070**

CORTE FLEXIBLE ALTO RENDIMIENTO

Long Life Flexible Cut
Coupe flexible longue durée



U118AF

21893

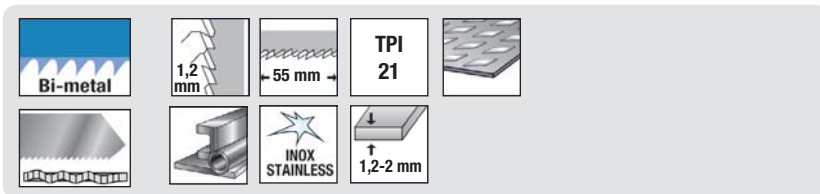

Dentado fresado y ondulado. Sierra flexible para aceros e inoxidable. Alto rendimiento.

Milled teeth and wavy set. Flexible blade for steel and stainless steel. Long life.

Dents fraisés et ondulés. Lame longue et flexible pour aciers et inoxydables. Durée de vie plus longue.

Mod.	TPI	Diente Tooth Dent mm	L mm	I mm		Nº Art.	€ pack
00070	21	1,2	76,5	55	5	21893	12,34

Mod **00110**

CORTE ACEROS, NO FERROSOS, ALUMINIO, PLÁSTICO

Steel, Non-Ferrous, Aluminium, Plastic Cut
Coupe Aciers, Non ferreux, Aluminium, Plastique



U127D

21894

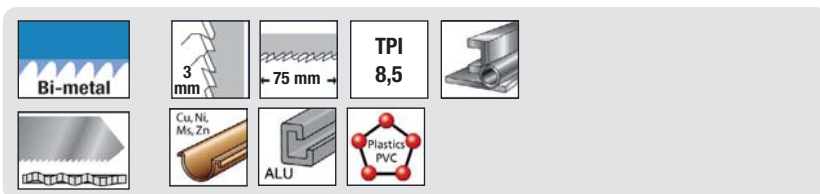

Dentado fresado alterno. Aceros, metales no ferrosos, aluminio y plásticos.

Milled teeth and side set. Steel, non-ferrous metals, aluminium and plastics.

Dents fraisés et avoyés. Aciers, métaux non ferreux, aluminiums et plastiques.

Mod.	TPI	Diente Tooth Dent mm	L mm	I mm		Nº Art.	€ pack
00110	8,5	3	100	75	5	21894	10,66

Línea 1m 19C1

SIERRAS CALAR INSERCIÓN "T"

"T" Insertion Jig Saw Blades

Lames scies insertion "T"

23
cm



Ref.	1910	1910	1910	1910	1910	1910	1910	1910	1930	1930	1940	1940	1940	1940	1940	1940	1940	1940	1940	1940
	020	040	050	060	070	090	100	110	020	030	010	020	030	040	050	060	070	080	100	
Pcs	5	5	5	5	5	5	5	5	5	5	5	5	5	5	5	5	5	5	5	5

Ref. 4995 - Nº Art. 72195: 480,85 €

Línea 1m 19C2

SIERRAS CALAR INSERCIÓN "T" + "U"

"T" + "U" Insertion Jig Saw Blades

Lames scies insertion "T" + "U"

24
cm



Ref.	1910	1910	1910	1910	1910	1915	1915	1940	1940	1940	1940	1940	1940	1940	1940	1945	1945	1945	1945
	020	040	050	070	100	00070	00110	010	030	040	060	070	080	100	140	00030	00040	00060	00070
Pcs	5	5	5	5	5	5	5	5	5	5	5	5	5	5	5	5	5	5	5

Ref. 4995 - Nº Art. 72196: 595,34 €

Display 20

SIERRAS CALAR INSERCIÓN "T"

"T" Insertion Jig Saw Blades

Lames scies insertion "T"



		Ref. 1940							
Mod.		Mod. 010	Mod. 020	Mod. 030	Mod. 030	Mod. 040	Mod. 040	Mod. 050	Mod. 060
Pcs		3	3	2	1	2	1	3	2
		Ref. 1940				Ref. 1930			
Mod.		Mod. 060	Mod. 070	Mod. 070	Mod. 080	Mod. 100	Mod. 020	Mod. 030	Mod. 200
Pcs		1	2	1	3	3	3	3	3
		Ref. 1910							
Mod.		Mod. 020	Mod. 040	Mod. 050	Mod. 060	Mod. 070	Mod. 090	Mod. 100	Mod. 110
Pcs		3	3	3	3	3	3	3	3

Ref. 4995 - Nº Art. 22391: 322,79 €

Display 21

SIERRAS CALAR INSERCIÓN "T" + "U"

"T" + "U" Insertion Jig Saw Blades

Lames scies insertion "T" + "U"



		Ref. 1940							
Mod.		Mod. 010	Mod. 030	Mod. 040	Mod. 060	Mod. 070	Mod. 080	Mod. 100	Mod. 140
Pcs		3	3	3	3	3	3	3	3
		Ref. 1910				Ref. 1930			
Mod.		Mod. 020	Mod. 040	Mod. 050	Mod. 070	Mod. 100	Mod. 020	Mod. 030	Mod. 200
Pcs		2	2	2	2	2	1	1	1
		Ref. 1945				Ref. 1915			
Mod.		Mod. 00030	Mod. 00040	Mod. 00060	Mod. 00060	Mod. 00070	Mod. 00020	Mod. 00070	Mod. 00110
Pcs		3	3	2	1	3	2	2	2

Ref. 4995 - Nº Art. 22280: 341,86 €



PUNTAS ATORNILLAR

Screwdriver Bits

Embouts vissage



PUNTAS ATORNILLAR

Screwdriver Bits

Embouts vissage

Ref. **1520**

PUNTA ATORNILLAR

Screwdriver Bit

Embout vissage

Standard



New!

ALLEN



Tipo Type	D mm	L mm	d mm		Nº Art.	€ pack		Nº Art.	€ pack
HEX	3	25	6,35	2	83771	1,16	5	33154	2,53
HEX	4	25	6,35	2	83772	1,16	5	33155	2,53
HEX	5	25	6,35	2	83773	1,16	5	33156	2,53

PHILLIPS



Tipo Type	D mm	L mm	d mm		Nº Art.	€ pack		Nº Art.	€ pack
PH	1	25	6,35	2	83774	1,16	5	33138	2,53
PH	1	50	6,35	2	83775	1,79	3	33157	2,69
PH	2	25	6,35	2	83776	1,16	5	33139	2,53
PH	2	50	6,35	2	83777	1,79	3	33158	2,69
PH	3	25	6,35	2	83778	1,16	5	33140	2,53
PH	3	50	6,35	2	83779	1,79	3	33159	2,69

POZIDRIVE



Tipo Type	D mm	L mm	d mm		Nº Art.	€ pack		Nº Art.	€ pack
PZ	1	25	6,35	2	83780	1,16	5	33141	2,53
PZ	1	50	6,35	2	83781	1,79	3	33160	2,69
PZ	2	25	6,35	2	83782	1,16	5	33142	2,53
PZ	2	50	6,35	2	83783	1,79	3	33161	2,69
PZ	3	25	6,35	2	83784	1,16	5	33143	2,53
PZ	3	50	6,35	2	83785	1,79	3	33162	2,69

Ref. **1520**

PUNTA ATORNILLAR

Screwdriver Bit
Embout vissage



New!

PLANA / Flat / Plate



Tipo Type	D mm	L mm	d mm		Nº Art.	€ pack		Nº Art.	€ pack
SL	4,5x0,6	25	6,35	2	83786	1,16	5	33151	2,53
SL	4,5x0,6	50	6,35				3	33170	2,69
SL	5,5x0,8	25	6,35	2	83787	1,16	5	33152	2,53
SL	5,5x0,8	50	6,35				3	33171	2,69
SL	6,5x1,2	25	6,35	2	83788	1,16	5	33153	2,53
SL	6,5x1,2	50	6,35				3	33172	2,69

TORX



Tipo Type	D mm	L mm	d mm		Nº Art.	€ pack		Nº Art.	€ pack
Tx	8	25	6,35				5	66723	2,64
Tx	10	25	6,35	2	83789	1,21	5	33144	2,64
Tx	10	50	6,35	2	83790	1,89	3	33163	2,83
Tx	15	25	6,35	2	83791	1,21	5	33145	2,64
Tx	15	50	6,35	2	83792	1,89	3	33164	2,83
Tx	20	25	6,35	2	83793	1,21	5	33146	2,64
Tx	20	50	6,35	2	83794	1,89	3	33165	2,83
Tx	25	25	6,35	2	83795	1,21	5	33147	2,64
Tx	25	50	6,35	2	83796	1,89	3	33166	2,83
Tx	27	25	6,35				5	33148	2,64
Tx	27	50	6,35				3	33167	2,83
Tx	30	25	6,35	2	83797	1,21	5	33149	2,64
Tx	30	50	6,35	2	83798	1,89	3	33168	2,83
Tx	40	25	6,35	2	83799	1,21	5	33150	2,64
Tx	40	50	6,35	2	83800	1,89	3	33169	2,83



TORX SEGURIDAD Security Torx / Torx Sécurité



Tipo Type	D mm	L mm	d mm		Nº Art.	€ pack
TS	10	25	6,35	2	80223	1,26
TS	15	25	6,35	2	80224	1,26
TS	20	25	6,35	2	80225	1,26
TS	25	25	6,35	2	80226	1,26
TS	27	25	6,35	2	80228	1,26
TS	30	25	6,35	2	80229	1,26
TS	40	25	6,35	2	80230	1,26

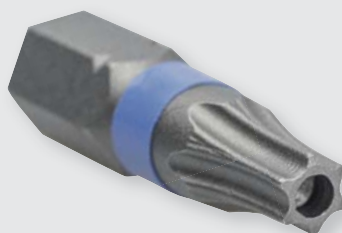

Display 63

PUNTA ATORNILLAR

Screwdriver Bit
Embout vissage



Ref. 1520 L25	∅	HEX 3	HEX 4	HEX 5	PH 1	PH 2	PH 3
	Pcs	5	5	5	5	5	5
	∅	PZ 1	PZ 2	PZ 3	SL 4,5	SL 5,5	SL 6,5
Ref. 1520 L50	Pcs	5	5	5	5	5	5
	∅	T 10	T 15	T 20	T 25	T 30	T 40
	Pcs	5	5	5	5	5	5
Ref. 1520 L50	∅	PH 1	PH 2	PH 3	PZ 1	PZ 2	PZ 3
	Pcs	3	3	3	3	3	3
	∅	SL 4,5	SL 5,5	SL 6,5	T 25	T 30	T 40
Pcs	3	3	3	3	3	3	

Ref. 4995 - N° Art. 37502: 329,05 €

Sets
1520

PUNTA ATORNILLAR

Screwdriver Bit
Embout vissage



Tipo
Type

PH-PZ

D mm	L mm	d mm		Nº Art.	€
PH: 1-2-3	25	6,35	7	33748	8,50
PZ: 1-2-3					

Tipo
Type

Tx

D mm	L mm	d mm		Nº Art.	€
10 15 20 25 30 40	25	6,35	7	33751	8,71

Tipo
Type

PH-PZ-SL

D mm	L mm	d mm		Nº Art.	€
PH: 1 - 2 (2 pcs.) - 3 +	25	6,35	12	33754	9,88
PZ: 1 - 2 (2 pcs.) - 3 +					
SL: 4,5x0,6 - 5,5x0,8 - 6,5-1,2					



Box-Pallet
1520

6 Sets

Nº Art.	€
68168	87,09



31
pcs

Cont. 1 set

	d mm: 6,35
2x PH1	1x T10
3x PH2	2x T15
1x PH3	2x T20

	d mm: 6,35
3x T25	3x T30
1x T40	

	d mm: 6,35
2x PZ1	
8x PZ2	
2x PZ3	

Adapt. Quick-Lock	
	L mm: 60 - d mm: 6,35



Ref. **1521**

PUNTA ATORNILLAR PRO

PRO Screwdriver Bit
Embout vissage PRO



Torsion

PHILLIPS



Tipo Type	D mm	L mm	d mm		Nº Art.	€ pack
PH	1	25	6,35	5	33173	3,32
PH	1	50	6,35	3	33192	6,12
PH	2	25	6,35	5	33174	3,32
PH	2	50	6,35	3	33193	6,12
PH	3	25	6,35	5	33175	3,32
PH	3	50	6,35	3	33194	6,12

POZIDRIVE



Tipo Type	D mm	L mm	d mm		Nº Art.	€ pack
PZ	1	25	6,35	5	33176	3,32
PZ	1	50	6,35	3	33195	6,12
PZ	2	25	6,35	5	33177	3,32
PZ	2	50	6,35	3	33196	6,12
PZ	3	25	6,35	5	33178	3,32
PZ	3	50	6,35	3	33197	6,12

PLANA / Flat / Plate



Tipo Type	D mm	L mm	d mm		Nº Art.	€ pack
SL	4,5x0,6	25	6,35	5	33186	5,70
SL	4,5x0,6	50	6,35	3	33204	7,92
SL	5,5x0,8	25	6,35	5	33187	5,70
SL	5,5x0,8	50	6,35	3	33205	7,92
SL	6,5x1,2	25	6,35	5	33188	5,70
SL	6,5x1,2	50	6,35	3	33206	7,92

TORX



Tipo Type	D mm	L mm	d mm		Nº Art.	€ pack
Tx	8	25	6,35	5	66725	5,37
Tx	10	25	6,35	5	33179	5,37
Tx	10	50	6,35	3	33198	7,59
Tx	15	25	6,35	5	33180	5,37
Tx	15	50	6,35	3	33199	7,59
Tx	20	25	6,35	5	33181	5,37
Tx	20	50	6,35	3	33200	7,59
Tx	25	25	6,35	5	33182	5,37
Tx	25	50	6,35	3	33201	7,59
Tx	27	25	6,35	5	33183	5,37
Tx	27	50	6,35	3	34144	7,59
Tx	30	25	6,35	5	33184	5,37
Tx	30	50	6,35	3	33202	7,59
Tx	40	25	6,35	5	33185	5,37
Tx	40	50	6,35	3	33203	7,59

Sets
1521

PUNTA ATORNILLAR PRO

PRO Screwdriver Bit
Embout vissage PRO



Tipo
Type

PH-PZ

D mm	L mm	d mm		Nº Art.	€
PH 1-2-3 PZ 1-2-3	25	6,35	7	33756	9,03



Tipo
Type

Tx

D mm	L mm	d mm		Nº Art.	€
10-15-20- 25-30-40	25	6,35	7	33758	11,61



Ref. **1522**

PUNTA ATORNILLAR SUPERIOR

Superior Screwdriver Bit
Embout vissage supérieur



Zirkonio

PHILLIPS



Tipo Type	D mm	L mm	d mm		Nº Art.	€ pack
PH	1	25	6,35	5	33207	7,09
PH	2	25	6,35	5	33208	7,09
PH	3	25	6,35	5	33209	7,09

POZIDRIVE



Tipo Type	D mm	L mm	d mm		Nº Art.	€ pack
PZ	1	25	6,35	5	33210	7,09
PZ	2	25	6,35	5	33211	7,09
PZ	3	25	6,35	5	33212	7,09

PLANA / Flat / Plate



Tipo Type	D mm	L mm	d mm		Nº Art.	€ pack
SL	4,5x0,6	25	6,35	5	33220	9,44
SL	5,5x0,8	25	6,35	5	33221	9,44
SL	6,5x1,2	25	6,35	5	33222	9,44

TORX



Tipo Type	D mm	L mm	d mm		Nº Art.	€ pack
Tx	10	25	6,35	5	33213	9,27
Tx	15	25	6,35	5	33214	9,27
Tx	20	25	6,35	5	33215	9,27
Tx	25	25	6,35	5	33216	9,27
Tx	27	25	6,35	5	33217	9,27
Tx	30	25	6,35	5	33218	9,27
Tx	40	25	6,35	5	33219	9,27

Sets
1522

PUNTA ATORNILLAR SUPERIOR

Superior Screwdriver Bit
Embout vissage supérieur



Tipo
Type

PH-PZ

D mm	L mm	d mm		Nº Art.	€
PH 1-2-3 PZ 1-2-3	25	6,35	7	33759	13,63



Tipo
Type

Tx

D mm	L mm	d mm		Nº Art.	€
10-15-20- 25-30-40	25	6,35	7	33761	28,84

Ref. **1527**

TOPE PROFUNDIDAD PLADUR

Plasterboard Depth Stop
Butée profondeur Placoplâtre



Tipo Type	D mm	L mm	d mm		Nº Art.	€ pack
PH	2	25	6,35	2	77339	3,39
PH	2	50	6,35	2	74858	4,23
PZ	2	25	6,35	2	81588	3,39
PZ	2	50	6,35	2	81589	4,23



Set 4 Pcs

Cont.	Nº Art.	€
PH2 - L25 PH2 - L50 PZ2 - L25 PZ2 - L50	81594	7,63

Ref. **1529**

ADAPTADORES PUNTAS ATORNILLAR

Screwdriver Bit Adaptors
Adaptateurs embouts vissage



Tipo Type	L mm	d mm		Nº Art.	€ pack
Quick Lock INOX / Stainless	60	6,35	1	82687	8,00



Tipo Type	L mm	d mm		Nº Art.	€ pack
Quick Lock	60	6,35	1	33746	6,67



Tipo Type	L mm	d mm		Nº Art.	€ pack
SDS plus	78	6,35	1	33745	17,98



Tipo Type	L mm	d mm		Nº Art.	€ pack
Magnético IND	58	6,35	1	33747	3,32

Adaptador Magnético para Tornillos
Magnetic Screw Adaptor
Adaptateur magnetique pour vis



Tipo Type	 mm	L mm	d mm		Nº Art.	€
Adapt.	6	65	6,35	1	42466	3,45
Adapt.	7	65	6,35	1	42472	3,45
Adapt.	8	65	6,35	1	42475	3,45
Adapt.	10	65	6,35	1	42478	3,67
Adapt.	12	65	6,35	1	42481	3,67
Adapt.	13	65	6,35	1	42483	3,67

* Interno / Internal / Intérieur

Set **1529**

Adaptador Magnético para Tornillos
Magnetic Screw Adaptor
Adaptateur magnetique pour vis

5 Pcs

D mm	L mm	d mm		Nº Art.	€
6-7-8-10-13	65	6,35	5	69751	17,66



Ref. **3407**

SET EXTRACTORES IMPACTO

Impact Extractor Set
Jeu extracteurs impact



17 Pcs

Nº Art.	€
72898	23,86



17
pcs

Extractores Impacto
Impact Extractors
Extracteurs impact
N.º 1 - 2 - 3 - 4

PH d mm: 6,35
PH1
PH2
PH3
L: 25 mm

PZ d mm: 6,35
PZ1
PZ2
PZ3
L: 25 mm

d mm: 6,35
Tx
T10
T15
T20
T25
T30
T40
L: 25 mm

Adapt. Quick-Lock
L mm: 60 - d mm: 6,35



Box-Pallet
3407

6 Sets

Nº Art.	€
74792	136,35

Ref. **1500**

BROCAS - PUNTAS ATORNILLAR

Screwdriver Bits – Drill Bits
Forets – Embouts vissage



20 Pcs.

Uds. pack	Nº Art.	€ 1 Set
1	18225	32,12

Puntas 1/4" (25 mm) T
Bits / Embouts
TX10 - TX15 - TX20 - TX25 - TX30



Brocas Metal 1/4"
Metal Drill Bits / Forets
ø 3 - 3,5 - 4 - 5 - 6 mm



Puntas 1/4" (25 mm) PH-PZ
Bits / Embouts
PH1 - PH2 - PZ1 - PZ2 - PZ3



Puntas 1/4" (50 mm) HEX-SL
Bits / Embouts
HEX4 - SL4,5 - SL5,5 - SL6,5 - Quick Lock



Ref. **1461**

SET BROCAS Y PUNTAS ATORNILLAR

Drill Bit & Screwdriver Bit Set
Jeu de forets et embouts vissage



72
pcs

Brocas Metal
Metal Drill Bits
Forets Métal

2 - 3 - 4 - 5 - 6 - 8 mm

Brocas Pared
Masonry Drill Bits
Forets Maçonnerie

4 - 5 - 6 - 8 mm

Brocas Madera
Wood Drill Bits
Forets Bois

3 - 4 - 5 - 6 - 8 mm

Adapt. Magnético
Magnetic Adapt.
Adapt. Magnétique

6 - 7 - 8
10 - 13 mm

Adapt. Quick-Lock

L mm: 60 - d mm: 6,35
1 pc.

Cuter Metálico
Hoja Partible
Heavy Duty Metal Box Cutter
Couteaux Métallique
à Lames Rétractables
1 pc.

Puntas Atornillar / Screwdriver Bits / Embouts Vissage

PH d mm: 6,35
3x PH1
4x PH2
3x PH3
← 25 mm →

PZ d mm: 6,35
3x PZ1
4x PZ2
2x PZ3
← 25 mm →

d mm: 6,35
Tx
T5 - T6
2x T10
T15
3x T20
4x T25
T27
3x T30
2x T40
← 25 mm →

d mm: 6,35
SQ
SQ 1
SQ 2
SQ 3
← 25 mm →

d mm: 6,35
SL
SL 4
SL 4,5
SL 5,5
SL 6
SL 6,5
← 25 mm →

d mm: 6,35
HEX
H2
H3
H4
H5
H6
← 25 mm →

Nº Art.	€
78504	53,91



DOBLE BLISTER

Double Blister
Double blister

METAL
Metal
Métal

370

CONSTRUCCIÓN
Construction
Construction

374

MADERA
Wood
Bois

379



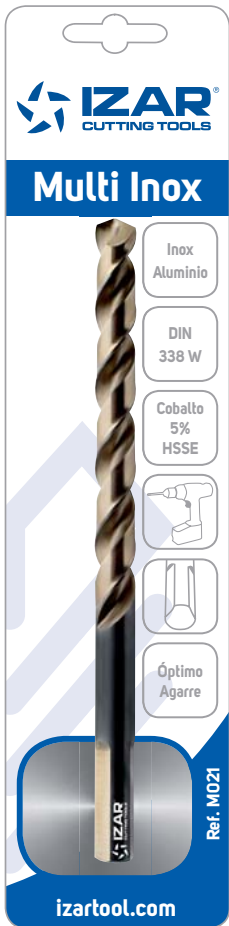

BROCA UNIVERSAL COBALTO MULTI INOX
Multi-STAINLESS Cobalt Universal Drill Bit
Foret universel Cobalt Multi INOX

Ref. **M021**



INOX
Stainless Steel

Aluminio
Aluminium

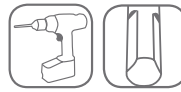

D mm	L mm	I mm		Nº Art.	€
1,00	34	12	2	67643	6,22 *
1,50	40	18	2	67644	5,91 *
2,00	49	24	2	67645	5,91 *
2,50	57	30	2	67646	5,38 *
3,00	61	33	2	67647	5,26 *
3,25	65	36	2	67648	6,22 *
3,50	70	39	2	67650	6,15 *
4,00	75	43	2	67651	6,61 *
4,25	75	43	1	67652	3,70
4,50	80	47	1	67653	3,70
5,00	86	52	1	67654	3,96
5,50	93	57	1	67655	5,01
6,00	93	57	1	67656	5,33
6,50	101	63	1	67657	6,02
7,00	109	69	1	67658	6,56
7,50	109	69	1	67659	7,00
8,00	117	75	1	67660	8,19
8,50	117	75	1	67661	8,54
9,00	125	81	1	67662	10,89
10,00	133	87	1	67663	12,09
11,00	142	94	1	67664	17,97
12,00	151	101	1	67665	22,19
13,00	151	101	1	67666	25,06

* € = 2 uds.

Línea 1m
M021

BROCA UNIVERSAL COBALTO MULTI INOX
Multi-STAINLESS Cobalt Universal Drill Bit
Foret universel Cobalt Multi INOX



∅	2	2,5	3	3,25	3,5	4	4,25	4,5	5	5,5	6	6,5	7	7,5	8	8,5	9	10	12
Pcs	5	5	5	5	5	5	5	5	5	5	5	5	5	5	5	5	5	5	5

Ref. 4995 - Nº Art. 70995: 693,64 €

Sets

BROCA UNIVERSAL COBALTO MULTI INOX
Multi-STAINLESS Cobalt Universal Drill Bit
Foret Universel Cobalt Multi INOX



∅ mm		Nº Art.	€
2-8	6	34204	22,37



∅ mm		Nº Art.	€
1-10 x0,50	19	34201	93,06



BROCA MANGO CILÍNDRICO COBALTO INOX
STAINLESS Cobalt Straight Shank Drill Bit
 Foret queue cylindrique Cobalt INOX

Ref. **M020** Onix M102

Inoxidable

- Inox Aluminio
- DIN 338 W
- Cobalto 5% HSSE

INOX
Stainless Steel

Aluminio
Aluminium

DIN 338 W

Cobalto 5% HSSE

D mm	L mm	l mm		Nº Art.	€
1,00	34	12	2	68049	4,62 *
1,50	40	18	2	68050	4,43 *
2,00	49	24	2	68052	4,43 *
2,50	57	30	2	68053	4,08 *
3,00	61	33	2	68054	3,99 *
3,25	65	36	2	68055	4,74 *
3,50	70	39	2	68056	4,66 *
4,00	75	43	2	68057	5,01 *
4,25	75	43	1	68058	2,80
4,50	80	47	1	68060	2,80
5,00	86	52	1	68061	3,01
5,50	93	57	1	68062	3,79
6,00	93	57	1	68063	4,04
6,50	101	63	1	68064	4,56
7,00	109	69	1	68065	4,98
7,50	109	69	1	68066	5,30
8,00	117	75	1	68067	6,19
8,50	117	75	1	68068	6,48
9,00	125	81	1	68069	8,25
10,00	133	87	1	68070	9,17
11,00	142	94	1	68071	13,62
12,00	151	101	1	68072	16,83
13,00	151	101	1	68073	19,02

* € = 2 uds.

Línea 1m M020

BROCA MANGO CILÍNDRICO COBALTO INOX
STAINLESS Cobalt Straight Shank Drill Bit
 Foret queue cylindrique Cobalt INOX

29 cm



Ø	2	2,5	3	3,25	3,5	4	4,25	4,5	5	5,5	6	6,5	7	7,5	8	8,5	9	10	12
Pcs	5	5	5	5	5	5	5	5	5	5	5	5	5	5	5	5	5	5	5

Ref. 4995 - Nº Art. 71036: 525,52 €

Sets **BROCA MANGO CILÍNDRICO COBALTO INOX**
STAINLESS Cobalt Straight Shank Drill Bit
 Foret queue cylindrique Cobalt INOX



Ø mm		Nº Art.	€
2-8	6	25367	18,08



Ø mm		Nº Art.	€
-10 x0,50	19	24636	75,01





BROCA MANGO CILÍNDRICO HSS SPEED POINT
Speed Point HSS Straight Shank Drill Bit
Foret queue cylindrique HSS Speed Point

Ref. **M013** Onix M100



Fundición
Cast Iron
Fonte

Aluminio
Aluminium

DIN 338 N
Rectificada

HSS Acero Rápido



D mm	L mm	I mm		Nº Art.	€
1,00	34	12	2	67996	2,60
1,50	40	18	2	67998	1,94
2,00	49	24	2	67999	1,84
2,50	57	30	2	68001	1,99
3,00	61	33	2	68002	1,77
3,25	65	36	2	68004	2,02
3,50	70	39	2	68005	1,99
4,00	75	43	2	68007	2,23
4,25	75	43	1	68008	1,24
4,50	80	47	1	68010	1,28
5,00	86	52	1	68011	1,45
5,50	93	57	1	68013	1,85
6,00	93	57	1	68014	1,90
6,50	101	63	1	68015	2,13
7,00	109	69	1	68016	2,60
7,50	109	69	1	68017	2,71
8,00	117	75	1	68018	3,12
8,50	117	75	1	68019	3,37
9,00	125	81	1	68020	4,11
10,00	133	87	1	68021	4,66
11,00	142	94	1	68022	6,47
12,00	151	101	1	68023	7,70
13,00	151	101	1	68025	8,76

* € = 2 uds.

Línea 1m
M013

BROCA MANGO CILÍNDRICO HSS SPEED POINT
Speed Point HSS Straight Shank Drill Bit
Foret queue cylindrique HSS Speed Point



∅	2	2,5	3	3,25	3,5	4	4,25	4,5	5	5,5	6	6,5	7	7,5	8	8,5	9	10	12
Pcs	5	5	5	5	5	5	5	5	5	5	5	5	5	5	5	5	5	5	5

Ref. 4995 - Nº Art. 71045: 249,75 €

Sets **BROCA MANGO CILÍNDRICO HSS SPEED POINT**
Speed Point HSS Straight Shank Drill Bit
Foret queue cylindrique HSS Speed Point



∅ mm		Nº Art.	€
2-8	6	25365	8,38



∅ mm		Nº Art.	€
1-10 x0,50	19	18808	35,90



BROCA MANGO REBAJADO HSS
 HSS Reduced Shank Drill Bit
 Foret queue reduit HSS

Ref. **M007** Onix M101



Fundición
 Cast Iron
 Fonte

Aluminio
 Aluminium

12,7 mm
 HSS

DIN 338 N
 Rectificada

D mm	L mm	I mm		Nº Art.	€
12,00	151	101	1	68026	8,65
12,50	151	101	1	68028	9,38
13,00	151	101	1	68029	9,64
13,50	160	108	1	68031	13,03
14,00	160	108	1	68032	13,83
14,50	169	114	1	68034	14,76
15,00	169	114	1	68035	14,93
15,50	178	120	1	68036	17,21
16,00	178	120	1	68037	17,85
16,50	184	125	1	68038	20,02
17,00	184	125	1	68039	20,02
17,50	191	130	1	68040	22,78
18,00	191	130	1	68041	23,98
18,50	198	135	1	68043	26,46
19,00	198	135	1	68044	26,46
19,50	204	140	1	68046	28,83
20,00	205	140	1	68047	33,21

Línea 1m
M007

BROCA MANGO REBAJADO HSS
 HSS Reduced Shank Drill Bit
 Foret queue reduit HSS



Ø	12	12,5	13	13,5	14	14,5	15	15,5	16	16,5	17	17,5	18	18,5	19	19,5	20
Pcs	2	2	2	2	2	2	2	2	2	2	2	2	2	2	2	2	2

Ref. 4995 - Nº Art. 71049: **642,06 €**



BROCA-MARTILLO SDS PLUS
 SDS plus Rotary Hammer Drill Bit
 Foret percussion SDS plus

Ref. **M890** Onix M304



Hormigón bloque
 Concrete Block
 Parpaing
 Ladrillo
 Brick
 Brique
 Cemento
 Cement
 Ciment



D mm	L mm	l mm		Nº Art.	€
04,00	110	50	1	67962	4,03
05,00	110	50	1	67963	2,93
05,00	160	100	1	67964	3,81
06,00	110	50	1	67965	3,00
06,00	160	100	1	67966	3,46
06,00	210	150	1	67967	5,73
06,00	260	200	1	67968	7,38
08,00	110	50	1	67969	3,80
08,00	160	100	1	67970	3,63
08,00	210	150	1	67971	5,19
08,00	260	200	1	67972	7,35
10,00	110	50	1	67973	4,34
10,00	160	100	1	67974	4,86
10,00	210	150	1	67975	5,84
10,00	260	200	1	67976	8,60
12,00	160	100	1	67977	5,16
12,00	210	150	1	67978	6,54
12,00	260	200	1	67979	9,29
14,00	160	100	1	67980	7,10
14,00	210	150	1	67981	10,36
16,00	160	100	1	67982	9,86
16,00	210	150	1	67983	12,02
16,00	260	200	1	67984	12,97
16,00	310	250	1	67986	13,87

Línea 1m M890

BROCA-MARTILLO SDS PLUS
 SDS plus Rotary Hammer Drill Bit
 Foret percussion SDS plus



Ø	4	5	6	8	10	5	6	8	10	12	14	16	8	10	12	14	16
	L110	L110	L110	L110	L110	L160	L160	L160	L160	L160	L160	L160	L210	L210	L210	L210	L210
Pcs	5	5	5	5	5	5	5	5	5	5	5	5	5	5	5	5	5

Ref. 4995 - Nº Art. 71056: 479,68 €

Línea 33 cm M890

BROCA-MARTILLO SDS PLUS
 SDS plus Rotary Hammer Drill Bit
 Foret percussion SDS plus



Ø	6	8	10	12	16	16
	L260	L260	L260	L260	L260	L310
Pcs	5	5	5	5	2	2

Ref. 4995 - Nº Art. 71059: 216,73 €

BROCA PORCELÁNICO
PORCELAIN Drill Bit
Foret PORCELAINE

Ref. **M882** Onix M302

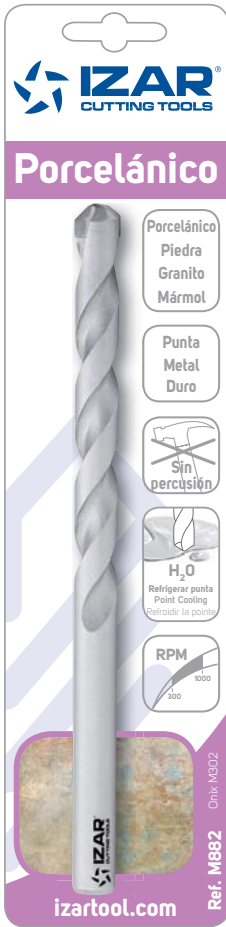

Porcelánico
 Porcelain
 Porcelaine

Piedra
 Stone
 Pierre

Granito
 Granite

Mármol
 Marble
 Marbre

Punta MD/HM
 Point

Sin percusión

RPM
 300 1000

H₂O
 Refrigerar punta
 Point Cooling
 Refroidir la pointe

D mm	L mm	I mm	📦	Nº Art.	€
3,00	85	42	1	67944	12,92
3,50	85	42	1	67945	12,92
4,00	85	50	1	67946	12,92
4,50	85	50	1	67947	12,92
5,00	85	50	1	67948	13,68
6,00	100	65	1	67950	14,32
7,00	125	75	1	67951	16,36
8,00	125	75	1	67952	17,72
9,00	150	90	1	67953	21,50
10,00	150	90	1	67954	21,50
11,00	150	90	1	67955	27,90

Línea 1m
M882

BROCA PORCELÁNICO
PORCELAIN Drill Bit
Foret PORCELAINE



ø	3	3,5	4	4,5	5	6	7	8	9	10	11
Pcs	4	2	4	2	5	5	4	2	4	4	2

Ref. 4995 - Nº Art. 71067: **623,74 €**



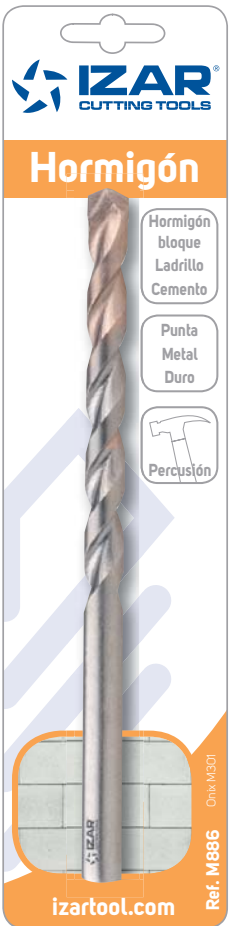

BROCA PUNTA METAL DURO PARED PROFESIONAL

Professional Concrete Carbide Tipped Drill Bit

Foret pointe carbure Béton Professionnel

Ref. **M886** Onix M301



Hormigón bloque
Concrete Block
Parpaing

Ladrillo
Brick
Brique

Cemento
Cement
Ciment



D mm	L mm	l mm		Nº Art.	€
3,00	60	35	1	67926	1,94
4,00	75	45	1	67927	1,94
5,00	85	40	1	67928	1,97
6,00	100	55	1	67929	2,12
7,00	100	55	1	67930	2,55
8,00	120	70	1	67931	2,85
9,00	120	70	1	67932	3,56
10,00	120	70	1	67933	3,56
12,00	150	90	1	67934	5,35
14,00	150	90	1	67935	7,88
16,00	150	90	1	67936	14,36

Línea 1m M886

BROCA PUNTA METAL DURO PARED PROFESIONAL

Professional Concrete Carbide Tipped Drill Bit

Foret pointe carbure Béton Professionnel



∅	3	4	5	6	7	8	9	10	12	14	16
Pcs	10	10	10	10	10	10	10	10	10	10	10

Ref. 4995 - Nº Art. 71071: 480,81 €

Sets **BROCA PUNTA METAL DURO PARED PROFESIONAL**
Professional Concrete Carbide Tipped Drill Bit
Foret pointe carbure Béton Professionnel



∅ mm		Nº Art.	€
4-10	5	30220	13,70



∅ mm		Nº Art.	€
3-10	8	21653	22,51



BROCA PUNTA METAL DURO PARED STANDARD
 Standard MASONRY Carbide Tipped Drill Bit
 Foret pointe carbure MAÇONNERIE Standard

Ref. **M880** Onix M300



D mm	L mm	l mm	📦	Nº Art.	€
3,00	60	30	1	67914	0,94
4,00	75	40	1	67916	0,99
5,00	85	50	1	67918	1,08
6,00	100	60	1	67919	1,23
7,00	100	60	1	67920	1,39
8,00	120	80	1	67921	1,53
9,00	120	80	1	67922	1,73
10,00	120	80	1	67923	1,86
12,00	150	80	1	67924	2,67
14,00	150	95	1	67925	3,90

Línea 1m M880

BROCA PUNTA METAL DURO PARED STANDARD
 Standard MASONRY Carbide Tipped Drill Bit
 Foret pointe carbure MAÇONNERIE Standard



∅	3	4	5	6	7	8	9	10	12	14
Pcs	10	10	10	10	10	10	10	10	10	10

Ref. 4995 - Nº Art. 71078: **173,23 €**

Sets
BROCA PUNTA METAL DURO PARED STANDARD
 Standard MASONRY Carbide Tipped Drill Bit
 Foret pointe carbure MAÇONNERIE Standard



∅ mm	📦	Nº Art.	€
4-10	5	30215	6,84



∅ mm	📦	Nº Art.	€
3-10	8	30219	10,23

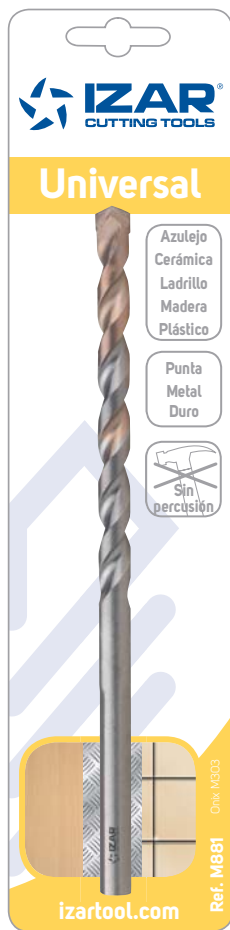

BROCA UNIVERSAL
UNIVERSAL Drill Bit
Foret UNIVERSEL

Ref. **M881** Onix M303



- Azulejo**
Tile
Carreau
- Cerámica**
Ceramics
Céramique
- Ladrillo**
Brick
Brique
- Madera**
Wood
Bois
- Plástico**
Plastics
Plastique



D mm	L mm	l mm		Nº Art.	€
4,00	103	50	1	67956	5,82
5,00	112	50	1	67957	5,35
6,00	123	60	1	67958	5,48
8,00	134	80	1	67959	6,38
10,00	135	80	1	67960	8,03
12,00	153	90	1	67961	10,14

Línea 33 cm
M881

BROCA UNIVERSAL
UNIVERSAL Drill Bit
Foret UNIVERSEL



ø	4	5	6	8	10	12
Pcs	5	5	5	5	5	5

Ref. 4995 - Nº Art. 71081: 205,95 €

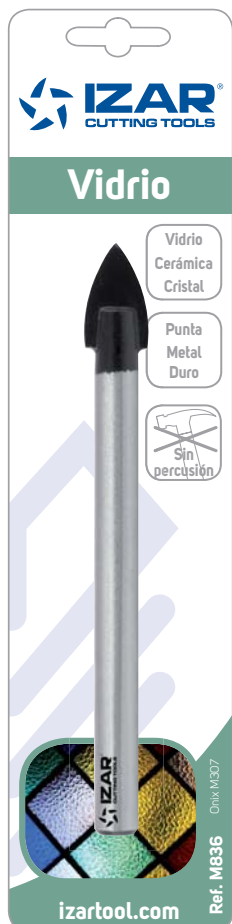

BROCA VIDRIO
GLASS Drill Bit
Foret VERRE

Ref. **M836** Onix M307



- Vidrio**
Glass
Verre
- Cerámica**
Ceramics
Céramique
- Cristal**
Crystal
Cristal



D mm	L mm		Nº Art.	€
3,00	58	1	67987	5,64
4,00	64	1	67989	6,18
5,00	70	1	67990	6,59
6,00	76	1	67992	6,96
8,00	83	1	67993	8,53
10,00	90	1	67995	11,94

Línea 33 cm
M836

BROCA VIDRIO
GLASS Drill Bit
Foret VERRE



ø	3	4	5	6	8	10
Pcs	5	5	5	5	5	5

Ref. 4995 - Nº Art. 71085: 229,19 €



BROCA PUNTA CENTRAR
Center Point Drill Bit
Foret auto-centreur

Ref. **M640** Onix M200



Madera
Wood
Bois
Aglomerado
Chipboard
Aggloméré

CRV

D mm	L mm	I mm		Nº Art.	€
3,00	61	33	1	68074	0,83
4,00	75	43	1	68076	0,84
5,00	86	52	1	68077	0,93
6,00	97	60	1	68078	1,13
7,00	109	69	1	68079	1,23
8,00	117	75	1	68080	1,55
9,00	125	80	1	68081	1,67
10,00	133	87	1	68082	1,77
11,00	142	89	1	68083	2,22
12,00	151	96	1	68084	2,44
13,00	191	96	1	68085	2,35
14,00	151	97	1	68086	2,56
15,00	160	100	1	68087	2,86
16,00	160	100	1	68088	3,26
18,00	180	120	1	68089	7,47
20,00	200	130	1	68090	9,09

Línea 1m
M640

BROCA PUNTA CENTRAR
Center Point Drill Bit
Foret auto-centreur



∅	3	4	5	6	7	8	9	10	11	12	13	14	15	16	18	20
Pcs	5	5	5	5	5	5	5	5	5	5	5	5	5	3	3	3

Ref. 4995 - Nº Art. 71092: **171,37 €**

Sets

BROCA PUNTA CENTRAR
Center Point Drill Bit
Foret auto-centreur



∅ mm		Nº Art.	€
4-10	5	30223	6,02



∅ mm		Nº Art.	€
3-10	8	30226	9,05





BROCA PLANA
Flat Bit
Mèche plate

Ref. **M650** Onix M201



D mm	L mm		Nº Art.	€
6,00	160	1	68091	1,94
8,00	160	1	68092	1,94
10,00	160	1	68093	2,03
12,00	160	1	68094	2,23
14,00	160	1	68095	2,32
16,00	160	1	68096	2,44
18,00	160	1	68097	2,74
20,00	160	1	68098	2,74
22,00	160	1	68099	3,04
24,00	160	1	68100	3,26
25,00	160	1	68101	3,70
26,00	160	1	68102	3,89
28,00	160	1	68103	3,99
30,00	160	1	68104	4,22
32,00	160	1	68105	4,49
36,00	160	1	68106	5,22
38,00	160	1	68107	5,51

Línea 1m
M650

BROCA PLANA
Flat Bit
Mèche plate



ø	6	8	10	12	14	16	18	20	22	24	25	26	28	30	32	36	38	L305
Pcs	10	10	10	10	10	10	10	10	5	5	5	5	5	5	5	5	5	1

Ref. 4995 - Nº Art. 71088: 380,59 €





PRESENTACIONES

Presentations

Presentations

PRESENTACIÓN IZAR EN LÍNEA

IZAR Line Presentation

Presentation IZAR ligne

382

PRESENTACIÓN IZAR EN CASCADA

IZAR Cascade Presentation

Presentation IZAR cascade

390

EXPOSITORES APILABLES

Stacking Exhibitors

Présentoirs apilables

394



¡NUEVA IMPLANTACIÓN DOBLE BLISTER!

New Double Blister Stock Offer!

Nouveau implantation Double Blister!



¡NUEVA IMPLANTACIÓN DOBLE BLISTER!

New Double Blister Stock Offer!

Nouveau implantation Double Blister!

1m
M650

BROCA PLANA
Flat Bit
Meche plate

Ref. 4995 - Nº Art. 71088: **380,59 €**
>> **Pag. 380**

1m
M880

BROCA PUNTA METAL DURO PARED STANDARD
Standard MASONRY Carbide Tipped Drill Bit
Foret pointe carbure MAÇONNERIE standard

Ref. 4995 - Nº Art. 71078: **173,23 €**
>> **Pag. 377**

1m
M640

BROCA PUNTA CENTRAR
Center Point Drill Bit
Foret auto-centreur

Ref. 4995 - Nº Art. 71092: **171,37 €**
>> **Pag. 379**

33cm
M881

BROCA UNIVERSAL
UNIVERSAL Drill Bit
Foret UNIVERSEL

Ref. 4995 - Nº Art. 71081: **205,95 €**
>> **Pag. 378**

1m
M013

BROCA MANGO CILÍNDRICO HSS SPEED POINT
Speed Point HSS Straight Shank Drill Bit
Foret queue cylindrique HSS Speed Point

Ref. 4995 - Nº Art. 71045: **249,75 €**
>> **Pag. 372**

33cm
M836

BROCA VIDRIO
GLASS Drill Bit
Foret VERRE

Ref. 4995 - Nº Art. 71085: **229,19 €**
>> **Pag. 378**

1m
M021

BROCA UNIVERSAL COBALTO MULTI INOX
Multi-STAINLESS Cobalt Universal Drill Bit
Foret Universel cobalt Multi INOX

Ref. 4995 - Nº Art. 70995: **693,64 €**
>> **Pag. 370**

1m
M882

BROCA PORCELÁNICO
PORCELAIN Drill Bit
Foret PORCELAINE

Ref. 4995 - Nº Art. 71067: **623,74 €**
>> **Pag. 375**

1m
M020

BROCA MANGO CILÍNDRICO COBALTO INOX
STAINLESS Cobalt Straight Shank Drill Bit
Foret queue cylindrique Cobalt INOX

Ref. 4995 - Nº Art. 71036: **525,52 €**
>> **Pag. 371**

1m
M886

BROCA PUNTA METAL DURO PARED PROFESIONAL
Professional Concrete Carbide Tipped Drill Bit
Foret pointe carbure Béton Professionnel

Ref. 4995 - Nº Art. 71071: **480,81 €**
>> **Pag. 376**

1m
M007

BROCA MANGO REBAJADO HSS
HSS Reduced Shank Drill Bit
Foret queue reduit HSS

Ref. 4995 - Nº Art. 71049: **642,06 €**
>> **Pag. 373**

1m
M890

BROCA-MARTILLO SDS PLUS
SDS plus Rotary Hammer Drill Bit
Foret percussion SDS plus

Ref. 4995 - Nº Art. 71056: **479,68 €**
>> **Pag. 374**

33cm
M890

BROCA-MARTILLO SDS PLUS
SDS plus Rotary Hammer Drill Bit
Foret percussion SDS plus

Ref. 4995 - Nº Art. 71059: **216,73 €**
>> **Pag. 374**

33cm
1870

CINCEL SDS PLUS
SDS plus Chisel
Burin SDS plus

Ref. 4995 - Nº Art. 71023: **80,22 €**
>> **Pag. 226**

* Sets no incluidos / Sets not included / Jeux non inclus **TOTAL: 5.152,48 €**

Set
M013

METAL
Metal
Métal

Ø mm		Nº Art.	€
2-8	6	25365	8,38

Set
M880

PARED
Masonry
Maçonnerie

Ø mm		Nº Art.	€
4-10	5	30215	6,84

Sets
M640

MADERA
Wood
Bois

Ø mm		Nº Art.	€
4-10	5	30223	6,02

MADERA GRANDE
Wood Big
Bois large

Ø mm		Nº Art.	€
3-10	8	30226	9,05

¡NUEVA IMPLANTACIÓN LÍNEA!

New Line Stock Offer!

Nouveau implantation Ligne!

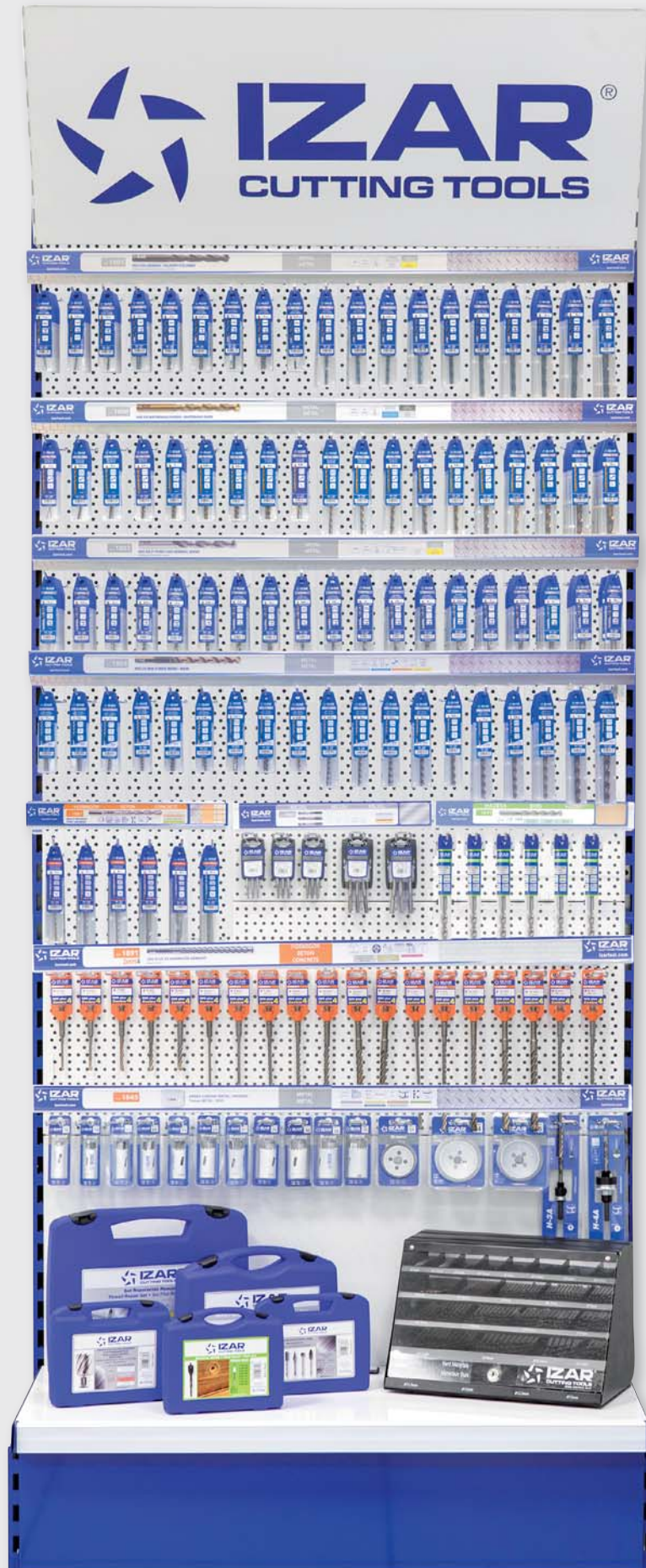

¡NUEVA IMPLANTACIÓN LÍNEA!

New Line Stock Offer!

Nouveau implantation Ligne!

1m
1001

BROCA MANGO CILÍNDRICO HSS

HSS Straight Shank Drill Bit
Foret queue cylindrique HSS

Ref. 4995 - Nº Art. 70942: **361,86 €** >> Pag. 51

1m
1006

BROCA MANGO CILÍNDRICO COBALTO

Cobalt Straight Shank Drill Bit
Foret queue cylindrique Cobalt

Ref. 4995 - Nº Art. 70936: **569,89 €** >> Pag. 27

1m
1002

BROCA MANGO CILÍNDRICO HSS SPEED POINT

Speed Point HSS Straight Shank Drill Bit
Foret queue cylindrique HSS Speed Point

Ref. 4995 - Nº Art. 70947: **397,96 €** >> Pag. 61

1m
1004

BROCA UNIVERSAL COBALTO **MULTI INOX**

Multi-STAINLESS Cobalt Universal Drill Bit
Foret universel Cobalt **Multi INOX**

Ref. 4995 - Nº Art. 70933: **565,79 €** >> Pag. 19

33cm
1881

BROCA UNIVERSAL

UNIVERSAL Drill Bit
Foret UNIVERSEL

Ref. 4995 - Nº Art. 71034: **197,38 €** >> Pag. 242

33cm
3003

JUEGO MACHOS MANO MÉTRICA

Metric Hand Tap Set
Jeu de tarauds à main métrique

Ref. 4995 - Nº Art. 70990: **321,31 €** >> Pag. 122

33cm
1641

BROCA PUNTA CENTRAR PRO

PRO Drill Bit
Foret auto-centreur PRO

Ref. 4995 - Nº Art. 71044: **109,25 €** >> Pag. 268

1m
1891

BROCA-MARTILLO SDS PLUS 4Z

4Z Cutter SDS plus Rotary Hammer Drill Bit
Foret percussion SDS plus 4Z

Ref. 4995 - Nº Art. 71015: **328,71 €** >> Pag. 211

1m
1645

SIERRA CORONA **METAL / MADERA**

METAL / WOOD Hole Saw
Trépan **MÉTAL / BOIS**

Ref. 4995 - Nº Art. 71040: **412,09 €** >> Pag. 248

TOTAL: 3.264,24 €

* **Maletines y Cabinet no incluidos**
Cases & Cabinet not included
Mallettes et Cabinet non inclus

ACCESORIOS LÍNEAS

Line Accessories
Accessoires ligne



Panel Inicial 1m

Initial Panel
Panneau initial

N° Art.	€
71120	631,41



Panel Adicional 1m

Additional Panel
Panneau supplémentaire

N° Art.	€
71169	538,48

ACCESORIOS LÍNEAS

Line Accessories
Accessoires ligne

Copete Liso 1m
Straight Top
Panneau supérieur lisse



N° Art.	€
59996	89,46

Copete Curvo 1m
Curve Top
Panneau supérieur curvado



Mod.	N° Art.	€
Standard	71112	150,29
Standard + Led	71113	150,29



Cajonera zócalo 100x40
Drawer
Tiroir

N° Art.	€
71111	175,34



Balda
Shelf
Étagère

Mod.	N° Art.	€
100x30 cm	64056	46,17
100x40 cm	64057	46,17



Balda-Cesta 30x30
Basket-Shelf
Étagère-Panier

N° Art.	€
71124	25,04



Balda-Podium 30x30
Podium-Shelf
Étagère-Podium

N° Art.	€
71110	25,04

ACCESORIOS LÍNEAS

Line Accessories
Accessoires ligne

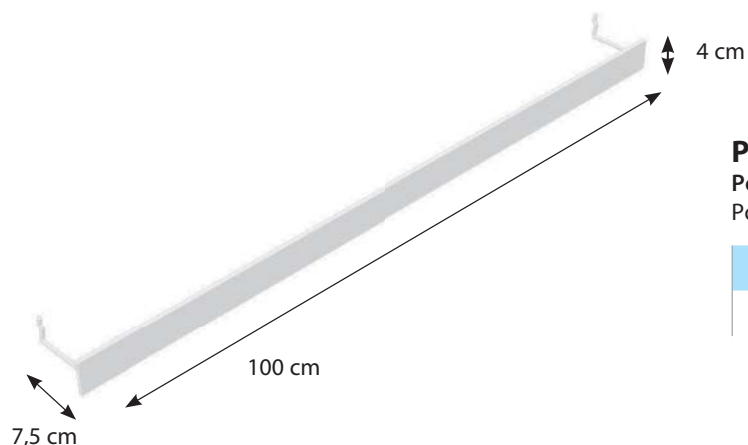

Porta-Cartel 1m

Poster-Holder
Porte-Affiche

N° Art.	€
69760	31,91

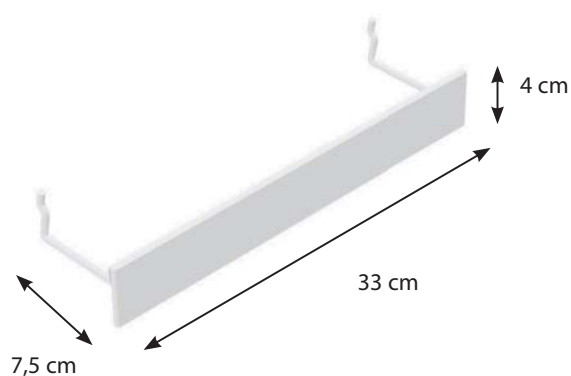

Porta-Cartel 33cm

Poster-Holder
Porte-Affiche

N° Art.	€
69781	17,35



Gancho simple

Simple Hook
Crochet simple

Mod.	N° Art.	€
4x100 mm	52956	0,53
4x150 mm	57810	0,71



Gancho doble

Double Hook
Crochet double

Mod.	N° Art.	€
4x150 mm	52957	1,06

ACCESORIOS LÍNEAS

Line Accessories
Accessoires ligne



1 Rail Rail / Raille

N° Art.	€
72270	2,25

3 Tope frontal / Front block Support adhesif frontal

N° Art.	€
71107	6,30

5 Divisor balda Shelf divider / Diviseur étagère

N° Art.	€
71106	1,68

2 Empujador Pusher / Pousser

N° Art.	€
71109	1,77

4 Tope trasero / Back block Support adhesif arrière

N° Art.	€
71108	3,65

6 Cartón Fin Gancho Hook End Carton / Carton fin crochet



	N° Art.	€
Plastic Pouch	71118	0,22
Doble Blister	71119	0,22

IMPLANTACIÓN DISPLAY 2 METROS

2 Metre Display Stock Offer

Offre implantation presentoir 2 metres



IMPLANTACIÓN DISPLAY 2 METROS

2 Metre Display Stock Offer

Offre implantation presentoir 2 metres

**Display
01**

BROCA-MARTILLO SDS PLUS 1

SDS plus Rotary Hammer Drill Bit 1
Foret percussion SDS plus 1

Ref. 4995 - N° Art. 22182: **527,09 €**

>> Pag. 215

**Display
02**

BROCA-MARTILLO SDS PLUS 2

SDS plus Rotary Hammer Drill Bit 2
Foret percussion SDS plus 2

Ref. 4995 - N° Art. 22183: **622,38 €**

>> Pag. 215

**Display
03**

BROCA-MARTILLO SDS MAX 4 PUNTAS

4-Cutter SDS max Rotary Hammer Drill Bit
Foret percussion SDS max 4 pointes

Ref. 4995 - N° Art. 22315: **1.304,59 €**

>> Pag. 221

**Display
04**

CINCELES SDS MAX / PLUS

SDS max / plus Chisels
Burins SDS max / plus

Ref. 4995 - N° Art. 22289: **434,06 €**

>> Pag. 228

**Display
05**

CORONA LIGERA PARED PROFESIONAL

Professional Concrete Light Hollow Core Bit
Trépan Béton Professionnel

Ref. 4995 - N° Art. 22418: **658,90 €**

>> Pag. 219

**Display
06**

CORONA PERFORADORA TALADRO PERCUTOR HORMIGÓN

Tapered Hollow Hammer Core Bit
Trépan pour perçuses percussion lourds Béton

Ref. 4995 - N° Art. 22463: **853,99 €**

>> Pag. 223

**Display
07**

BROCA PUNTA METAL DURO PARED PROFESIONAL

Professional Concrete Carbide Tipped Drill Bit
Foret pointe carbure Béton Professionnel

Ref. 4995 - N° Art. 22191: **569,85 €**

>> Pag. 236

**Display
10**

BROCAS MADERA PALA Y 3 PUNTAS

Wood Drill Bits Flat & 3-Pointed
Forets Bois mèches plates & 3-pointes

Ref. 4995 - N° Art. 22184: **320,11 €**

>> Pag. 271

**Display
12**

PORTA-BROCAS TALADROS PORTÁTILES Y ESTACIONARIOS

Portable & Stationary Drilling Machine Drill-Chucks
mandrins Perçuses Portables & Fixes

Ref. 4995 - N° Art. 22334: **809,66 €**

>> Pag. 83

**Display
13**

BROCA MANGO CILÍNDRICO COBALTO

Cobalt Straight Shank Drill Bit
Foret queue cylindrique Cobalt

Ref. 4995 - N° Art. 22181: **567,67 €**

>> Pag. 27

**Display
14**

BROCA MANGO CILÍNDRICO HSS

HSS Straight Shank Drill Bit
Foret queue cylindrique HSS

Ref. 4995 - N° Art. 22162: **401,11 €**

>> Pag. 51

**Display
18**

BROCA MANGO REBAJADO HSS

HSS Reduced Shank Drill Bit
Foret queue réduit HSS

Ref. 4995 - N° Art. 22352: **593,56 €**

>> Pag. 65

**Display
19**

SIERRA CORONA METAL / MADERA

METAL / WOOD Hole Saw
Trépan MÉTAL / BOIS

Ref. 4995 - N° Art. 22220: **881,59 €**

>> Pag. 248

**Display
20**

SIERRAS CALAR INSERCIÓN "T"

"T" Insertion Jig Saw Blades
Lames Scies insertion "T"

Ref. 4995 - N° Art. 22391: **322,79 €**

>> Pag. 356

**Display
23**

JUEGOS CASSETTE MADERA Y CONSTRUCCIÓN

Wood & Construction Cassette Sets
Jeux cassette Bois & Construction

Ref. 4995 - N° Art. 22372: **395,50 €**

>> Pag. 272

**Display
24**

SETS BROCAS MANGO CILINDRICO HSS + HSSE

HSS + HSSE Straight Shank Drill Bit Sets
Jeux forets queue cylindrique HSS + HSSE

Ref. 4995 - N° Art. 22320: **487,46 €**

>> Pag. 29

**Display
61**

BROCA-MARTILLO SDS PLUS 4Z

4Z Cutter SDS plus Rotary Hammer Drill Bit
Foret percussion SDS plus 4Z

Ref. 4995 - N° Art. 29487: **430,39 €**

>> Pag. 212

TOTAL: 10.180,70 €

IMPLANTACIÓN DISPLAY 1 METRO

1 Metre Display Stock Offer

Offre Implantation presentoir 1 metre



Display 01

BROCA-MARTILLO SDS PLUS 1
SDS plus Rotary Hammer Drill Bit 1
Foret percussion SDS plus 1

Ref. 4995 - N° Art. 22182: **527,09 €**

>> Pag. 215

Display 02

BROCA-MARTILLO SDS PLUS 2
SDS plus Rotary Hammer Drill Bit 2
Foret percussion SDS plus 2

Ref. 4995 - N° Art. 22183: **622,38 €**

>> Pag. 215

Display 07

BROCA PUNTA METAL DURO PARED PROFESIONAL
Professional Concrete Carbide Tipped Drill Bit
Foret pointe carbure Béton Professionnel

Ref. 4995 - N° Art. 22191: **569,85 €**

>> Pag. 236

Display 10

BROCAS MADERA PALA Y 3 PUNTAS
Wood Drill Bits Flat & 3-Pointed
Forets Bois mèches plates & 3-pointes

Ref. 4995 - N° Art. 22184: **320,11 €**

>> Pag. 271

Display 13

BROCA MANGO CILÍNDRICO COBALTO
Cobalt Straight Shank Drill Bit
Foret queue cylindrique Cobalt

Ref. 4995 - N° Art. 22181: **567,67 €**

>> Pag. 27

Display 14

BROCA MANGO CILÍNDRICO HSS
HSS Straight Shank Drill Bit
Foret queue cylindrique HSS

Ref. 4995 - N° Art. 22162: **401,11 €**

>> Pag. 51

Display 19

SIERRA CORONA METAL / MADERA
METAL / WOOD Hole Saw
Trépan MÉTAL / BOIS

Ref. 4995 - N° Art. 22220: **881,59 €**

>> Pag. 248

Display 23

JUEGOS CASSETTE MADERA Y CONSTRUCCIÓN
Wood & Construction Cassette Sets
Jeux cassette Bois & Construction

Ref. 4995 - N° Art. 22372: **395,50 €**

>> Pag. 272

TOTAL: 4.285,30 €

ACCESORIOS DISPLAYS

Display Accessories
Accessoires presentoir

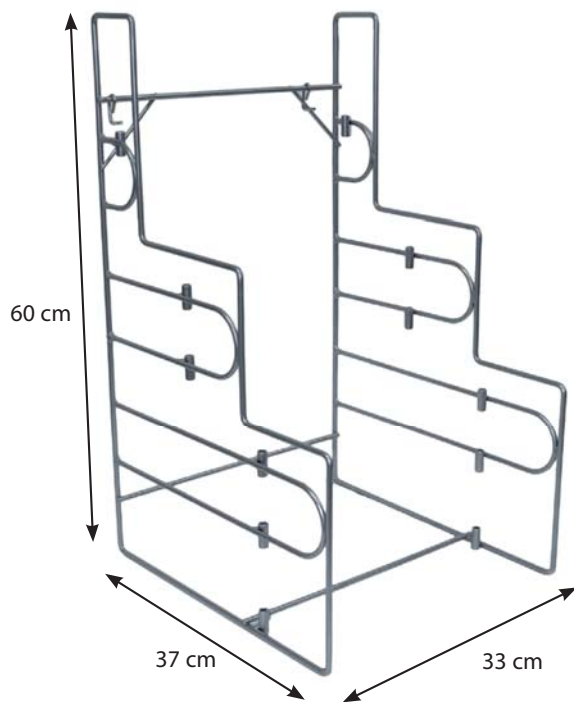

Display-Cascada
Cascade-Display
Display-Cascade

N° Art.	€
20182	44,38

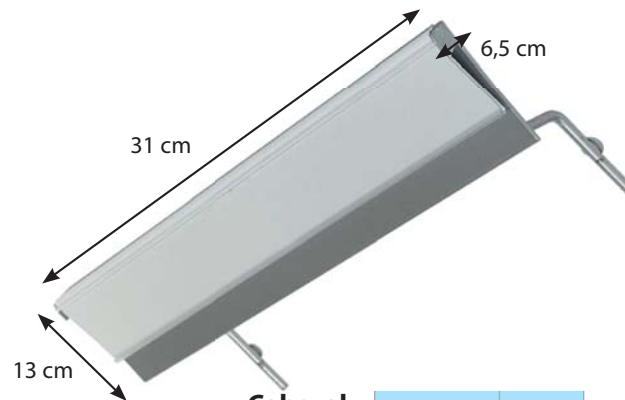

Cabezal
Header
Tête

N° Art.	€
22651	12,53



Display-Línea
Line-Display
Display-Ligne

N° Art.	€
22650	27,49



Gancho-08
Hook-08
Crochet-08

N° Art.	€
51837	11,09



Gancho-10
Hook-10
Crochet-10

N° Art.	€
51840	11,81

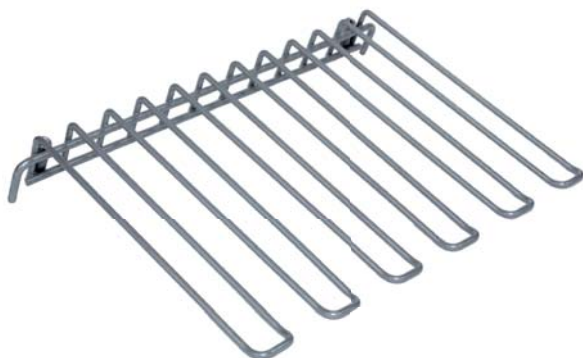

Gancho-06-Doble
Hook-06-Double
Crochet-06-Double

N° Art.	€
22653	12,31



Gancho-08-Doble
Hook-08-Double
Crochet-08-Double

N° Art.	€
33241	14,03

SISTEMA DE EXPOSITORES APILABLES

Stacking Exhibitors System
Système présentoirs empilables



1.

2.

3.

Expo
1602 1.

EXPOSITOR BROCAS ESCALONADAS

Step Drill Display
Présentoirs forets étagés

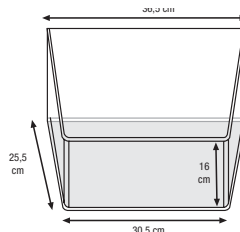

15 Pcs

N° Art. 65184 **1.401,94** €

Cap. mm	N° Art.	Uds.
4-12	12048	2
4-20	12054	2
6-30	12060	2
9-36	12066	2
12-20	56798	2
20-30	56799	2
30-40	60715	1
40-50	60716	1
50-60	60717	1

Expo
9200 2.

EXPOSITOR FRESAS ROTATIVAS

Rotary Burr Display
Présentoirs fraises limes rotatives carbure

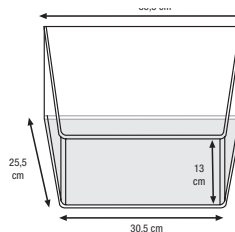

48 Pcs

N° Art. 57079 **1.424,32** €

Ref.	Diam. mm	N° Art.	Uds.
9260	06,00X06,00	44141	2
	08,00X06,00	44142	2
	09,60X06,00	44143	2
	12,70X06,00	44144	2
9251	06,00X06,00	44438	2
	08,00X06,00	44439	2
	09,60X06,00	44440	2
	12,70X06,00	44441	2
9254	06,00X06,00	44488	2
	08,00X06,00	44494	2
	09,60X06,00	44500	2
	12,70X06,00	44512	2
9258	06,00X06,00	44721	2
	08,00X06,00	44722	2
	09,60X06,00	44723	2
	12,70X06,00	44724	2
9267	06,00X06,00	44792	2
	08,00X06,00	44793	2
	10,00X06,00	44794	2
	12,70X06,00	44795	2
9268	06,00X06,00	44808	2
	08,00X06,00	44809	2
	09,60X06,00	44811	2
	12,70X06,00	44814	2

Expo
1667 3.

EXPOSITOR CORONAS REAFILABLES HSS

HSS Resharpenable Hole Saw Exhibitor
Présentoir fraises à trépaner HSS

31 Pcs

N° Art. 66804 **945,88** €

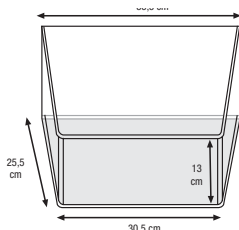

Diam.	N° Art.	Uds.	Diam.	N° Art.	Uds.	Diam.	N° Art.	Uds.	Diam.	N° Art.	Uds.
12	56569	1	20	56154	1	28	56587	1	39	56594	1
13	56570	1	21	56582	1	29	56588	1	40	56161	1
14	56572	1	22	56155	1	30	56158	1	42	56596	1
15	56573	1	23	56583	1	32	56159	1	45	56597	1
16	56152	1	24	56584	1	33	56590	1	48	56163	1
17	56576	1	25	56156	1	35	56160	1	50	56164	1
18	56578	1	26	56585	1	36	56591	1	65	56602	1
19	56579	1	27	56157	1	38	56593	1			

CONDICIONES GENERALES VENTA

General Selling Conditions

Conditions générales de vente en France

1. VENCIMIENTOS FIJOS

En caso de fechas fijas de pago que rebasen los plazos estipulados giraremos a la fecha fijada pero inmediata anterior, según corresponda, siendo el plazo máximo en todo caso de 60 días, fecha factura o envío.

2. SEGURO

Las mercancías viajarán por exclusiva cuenta y riesgo del comprador, siendo siempre a cargo del mismo la prima del seguro que se realice, en los casos que el cliente desee asegurarla.

3. RECLAMACIONES

Se atenderán aquellas reclamaciones que se planteen dentro de los 8 días siguientes a la recepción del material no aceptando ninguna devolución sin el previo conocimiento de IZAR Cutting Tools S.A.L.

4. DEVOLUCIONES

Sólo se aceptarán las devoluciones por defecto de fabricación o error atribuible a IZAR. No se aceptarán devoluciones sin previa autorización de IZAR o de nuestro delegado o representante. Las devoluciones serán a portes pagados e irán acompañadas de la factura original. No se admitirán devoluciones procedentes de promociones ni en estuches defectuosos. Toda devolución originará una nota de cargo del 20% de su valor en concepto de manipulación e inspección de control de calidad.

5. CONDICIONALIDAD

La aceptación de las mercancías sin el rechazo inmediato por parte del comprador supone la aprobación de estas condiciones generales de venta y su modificación solamente tendrá validez si consta por escrito la conformidad de IZAR.

6. I.V.A.

Los precios están sujetos al Impuesto sobre el Valor Añadido, siendo a cargo del cliente el recargo correspondiente.

7. GARANTÍAS

Todas las herramientas están garantizadas contra cualquier defecto de fabricación y materiales, sin responsabilizarse IZAR de su utilización inadecuada. En todo caso, nuestra responsabilidad estará limitada al valor de la herramienta suministrada. Nos reservamos el derecho de modificar, sin previo aviso, las dimensiones, calidades del acero y, en general, todas las características técnicas de las herramientas. No será

sustituída ninguna herramienta sin el informe previo de nuestro Dpto. de Control de Calidad.

8. PORTES

Se suministrarán con franquicia de portes todos aquellos envíos cuyo valor neto de factura supere los 180 € netos por cada envío en territorio peninsular e Islas Baleares; 300 € en Canarias, Ceuta, Melilla y Andorra. En cualquier caso IZAR se reserva el derecho de utilizar el medio de envío más económico. En las capitales donde IZAR tenga establecidos depósitos de distribución, esta cláusula se aplicará para las reexpediciones a otras poblaciones de la provincia.

9. IMPORTE MÍNIMO POR PEDIDO

Queda establecido como pedido mínimo la cantidad de 60 € netos. Los pedidos inferiores se cobrarán al contado o por reembolso.

10. RESERVA DE DOMINIO

Nuestras ventas se consideran siempre bajo la condición de Reserva de dominio según el artículo 1.506 C.C. hasta que se haya hecho efectivo íntegramente el pago de todo lo adeudado.

11. JURISDICCIÓN COMPETENTE

Para cualquier discrepancia acerca de la interpretación de estas condiciones o litigio por razón de incumplimiento por cualquiera de las partes se someten ambas al fuero de los Juzgados y Tribunales de Bilbao, con renuncia al que pudiera corresponderles.

12. NOTA IMPORTANTE SOBRE DISPLAYS MODULARES

Los Displays Modulares son propiedad de IZAR y la cesión sin costo para su uso a nuestros clientes se hace bajo las siguientes condiciones:

- Pedido inicial del Programa Completo.
- Uso único y exclusivo para los productos suministrados por IZAR.
- Ejercicio de un mantenimiento razonable que evite daños al Display.

El sistema de Displays modulares está patentado por IZAR. La infracción de dicha patente dará lugar a las acciones legales pertinentes.

1. ECHEANCES

Quelle que soit la date fixée pour le paiement des factures, celui-ci doit être effectué au maximum 30 jours après l'envoi ou la date de facture.

2. ASSURANCE

Le risque lié à l'envoi des marchandises est assumé exclusivement par l'acheteur, toute latitude lui étant laissée s'il désire les assurer.

3. RECLAMATIONS

Seront prises en compte les réclamations portées à la connaissance d'IZAR Cutting Tools S.A.L. dans un délai de 8 jours suivant la réception des marchandises. Aucun retour ne sera accepté si cette condition préliminaire n'est pas satisfaite.

4. RETOURS

Seront acceptés les retours de marchandises pour défaut de fabrication ou erreur imputable à IZAR. Ne sera accepté aucun retour de marchandises sans accord préalable de notre part ou de notre représentant.

Les retours s'effectueront port payé et seront accompagnés de la facture originale. En aucun cas ne seront acceptés les retours de marchandises liées à des promotions ou en emballages defectueux. Les avoirs seront minorés de 20% de la valeur de la marchandise pour manipulation et inspection du contrôle de qualité.

5. CONDITIONNALITE

L'acceptation des marchandises de la part de l'acheteur implique l'acceptation de ces conditions générales de vente et leur modification ne sera valable qu'après approbation écrite de la part d'IZAR.

6. T.V.A.

Les prix ne sont pas assujettis à la Taxe sur la Valeur Ajoutée.

7. GARANTIES

Tous les outils sont garantis contre les défauts de fabrication, IZAR ne pouvant en aucun cas être rendu responsable en cas d'utilisation

inadéquate de ceux-ci. En tout état de cause, notre responsabilité se limitera à la valeur de l'outil fourni. Nous nous réservons le droit de modifier, sans information préalable, les dimensions, qualités d'acier et en général toutes les caractéristiques techniques des outils. Aucun outil ne sera remplacé sans l'avis préalable de notre département de contrôle de qualité.

8. PORTS

Seront expédiées en franco de port en France Métropolitaine toutes les commandes dont le montant net dépasse les 300 €. IZAR se réserve le droit d'utiliser le moyen de transport le plus économique.

9. MONTANT MINIMUM DES COMMANDES

Le montant minimum des commandes est de 60 € nets.

10. RESERVE DE PROPRIETE

IZAR conserve tous les droits de propriété sur ses ventes jusqu'au paiement intégral des sommes dues.

11. JURIDICTION COMPETENTE

Tout litige relatif à l'interprétation de ces conditions ou au manquement de l'une des parties à ses obligations est de la compétence du Tribunal de Commerce de Bilbao.

12. NOTE IMPORTANTE SUR LES PRESENTOIRS MODULAIRES

Les présentoirs modulaires sont propriété d'IZAR et leur cession sans coût à nos clients pour leur utilisation se fait sous les conditions suivantes:

- Commande initiale du programme complet.
- Utilisation exclusive de produits fournis par IZAR.
- Entretien raisonnable qui évite les dommages au présentoir.

Le système de présentoirs modulaires est breveté par IZAR. Le non-respect dudit brevet donnera lieu aux actions légales nécessaires.

ÍNDICE SÍMBOLOS

Symbol Index
Index de symboles



Ángulo Punta
Point Angle
Angle de pointe

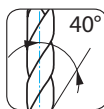

Ángulo de Hélice
Helix Angle
Angle d'hélice

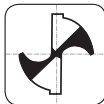

Afilado DIN 1412 C
Split Point DIN 1412 C
Affûtage DIN 1412 C



Mango 3 Planos
3-Flat Shank
Attachement 3 plans



Taladro Portátil
Portable Drilling Machine
Perceuse à main

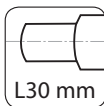

Mango Rebajado
Reduced Shank
Queue réduit



Punta Metal Duro
Carbide Tipped
Pointe carbure

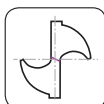

Afilado Universal
Universal Point
Affûtage universel



Sin Percusión
No Percussion
Sans percussion



Percusión
Percussion
Percussion

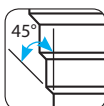

Ángulo Broca Escalonada
Step Drill Angle
Angle de foret etagé



Conicidad
Taper
Conicité



Puntos Soldadura
Welding Point
Points soudure



Punta Centrar DIN 1412 E
Center Point DIN 1412 E
Pointe À Centrer DIN 1412 E



Punta Centrar DIN 1412 E
Center Point DIN 1412 E
Pointe à centrer DIN 1412 E

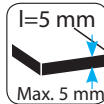

l=5 mm
Espesor Material
Material Thickness
Épaisseur matériel

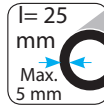

l= 25 mm
Espesor Tubo
Pipe Thickness
Épaisseur tuyau

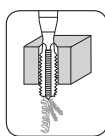

Agujero Pasante
Through Hole
Trou débouchant

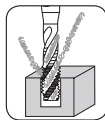

Agujero Ciego
Blind Hole
Trou borgne

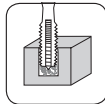

Agujero Ciego
Blind Hole
Trou borgne

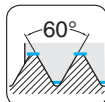

Rosca Standard
Standard Thread
Filetage standard

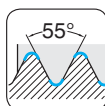

Rosca de tubo cilíndrica
Straight Pipe Thread
Filetage tubes cylindriques

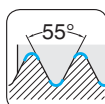

Rosca Whitworth cilíndrica
Straight Whitworth Thread
Filetage Whitworth cylindrique

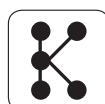

Plástico
Plastic
Plastique



Ángulo Avellanado
Countersink Angle
Angle de fraisage

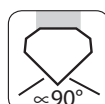

Ángulo Avellanado
Countersink Angle
Angle de fraisage

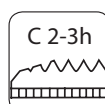

C 2-3h
Entrada Macho
Tap Point
Entrée de taraud



Ángulo de Hélice
Helix Angle
Angle d'hélice



Entrada GUN
GUN Chamfer
Entrée GUN



Corte al Centro
Center Cutting
Coupe au centre

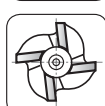

Sin Corte al Centro
Non Center Cutting
Sans Coupe Au Centre



Corte a Izquierda
Left hand Cutting
Coupe à gauche



Magnético
Magnetic
Magnétique



Cabezal Zentro4
Zentro4 head
Tête Zentro4



Hormigón Reforzado
Reinforced Concrete
Béton armé

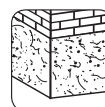

Hormigón
Concrete
Béton



Hormigón Bloque
Concrete Block
Parpaing



Ladrillo
Brick
Brique



Cabezal 4 Puntas
4-Cutter Head
Tête 4 Pointes

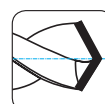

Punta MD Afilada
Carbide Split Point
Affûtage Pointe Carbure



Porcelánico
Porcelain
Porcelaine



Refrigeración Agua
Water Cooling
Refrigeration eau

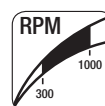

RPM
R.P.M.
R.P.M.



Herramienta Diamante
Diamond Tool
Outil Diamant



Amoladora
Disc Grinder
Meuleuse



Cerámica
Ceramics
Céramique

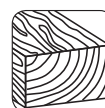

Madera
Wood
Bois



Vidrio
Glass
Verre

ÍNDICE SÍMBOLOS

Symbol Index
Index de symboles



Metal
Metal
Métal



Máquina Perforadora
Core Drilling Machine
Carotteuse électrique

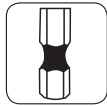

Inserción Rápida 1/4
Quick Shank 1/4
Attache rapide 1/4



Bujía
Spark Plug
Bougie



Abrasivos
Abrasives
Abrasifs
Abrasivos



Pulido
Sanding
Poncer

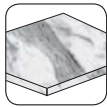

Mármol
Marble
Marbre

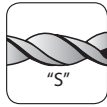

Perfil Parabólico "S"
S Parabolic Profile
Profil parabolique S



Madera Blanda
Soft Wood
Bois tendre



Madera Dura
Hard Wood
Bois dur

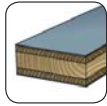

Contrachapado
Plywood
Contreplaque



Madera+Clavos
Wood+Nails
Bois+Clous



Metal
Metal
Métal

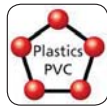

Plástico
Plastics
Plastique



Cristal
Glass
Verre



Válido Mango Multi-Función
Multi-Tool
Multifonction



Fibra Vidrio
Fibreglass
Fibre verre
Fibra Vidrio
Fibreglass



Pladur
Drywall
Plâtre



No ferrosos
Non-ferrous
Non ferreux



Perfiles
Profiles
Profils



Parquet-Laminados
Laminated-Parquet
Parquet-laminés



GFK



Cerámica
Ceramics
Céramique



Grout-Mortero
Grout-Mortar
Coulies-Mortier



Aislamiento
Isolating
Isolant



Caucho
Rubber
Caoutchouc



Cuero
Leather
Cuir



Restos blandos (pegamento, moqueta, silicona...)
Soft remains (glue, carpet, silicone...)
Restes tendres (colle, moquette, silicone...)

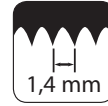

Distancia entre Dientes
Distance among Teeth
Distance entre les dents

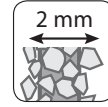

Espesor Dentado
Teeth Thickness
Épaisseur denture

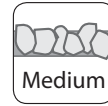

Tipo Dentado
Teeth Type
Type denture

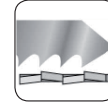

Dentado Alterno Basto
Rough Side Teeth
Denture avoyée gros

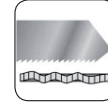

Dentado Ondulado Fino
Fine Wavy Teeth
Denture ondulé fin

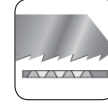

Dentado Rectificado Cónico
Conically Ground Teeth
Denture conique dépouillée

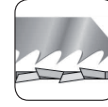

Dentado Alterno Diagonal
Diagonally Side Teeth
Denture avoyée diagonale



Punta Atornillar HEX
HEX Screwdriver Bit
Embout vissage HEX



Punta Atornillar PH
PH Screwdriver Bit
Embout vissage PH



Punta Atornillar PZ
PZ Screwdriver Bit
Embout vissage PZ



Punta Atornillar SL
SL Screwdriver Bit
Embout vissage SL



Punta Atornillar Tx
Tx Screwdriver Bit
Embout vissage Tx



Punta Atornillar Ts
Ts Screwdriver Bit
Embout vissage Ts



Entrada Hexagonal
HEX Input
Entrée hexagonale

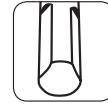

Mango 3 Planos
3-Flat Shank
Attachement 3 plans

Búsqueda por referencia (REF. - PÁGINA)

Search by reference (Ref. - Page)

Recherche par référence (Ref. - Page)

Ref.	Pag.	Ref.	Pag.	Ref.	Pag.	Ref.	Pag.	Ref.	Pag.	Ref.	Pag.	Ref.	Pag.
1001	50	1470	30-54-64	1663	113	1871	229	3001	130	4060	108	8925	196
1002	60	1476	69	1664	111-114	1872	227	3003	122	4061	109	8930	197
1003	72	1482	230	1665	114	1875	225	3005	149	4062	110	8940	197
1004	19	1485	241	1667	111	1877	233	3006	149	4067	107	8950	198
1005	34	1486	237	1669	285	1879	231	3010	128	4070	99	8960	198
1006	26	1487	237	1670	287	1880	238	3012	134	4071	100	8970	199
1007	65	1488	241	1671	287	1881	242	3016	135	4072	101	8990	200
1009	75	1489	213	1672	288	1882	230	3020	126	4074	104	8991	200
1010	45	1490	75	1673	288	1883	232	3023	131	4075	97/110	8992	201
1012	66	1491	75	1674	286	1886	234	3026	135	4076	103		
1013	56	1492	75	1676	286	1889	243	3030	121	4077	98	9001	293
1015	40	1494	218	1677	287	1890	214	3032	133	4078	97	9015	38
1016	22	1497	218	1678	286	1891	210	3036	124	4079	102	9016	154
1020	31	1499	75	1679	285	1892	220	3037	125				
1021	16			1681	288	1894	222	3040	132				
1025	67			1682	289	1899	218			4223	187	9100	39
1027	37	1500	368	1685	285			3100	136	4228	189		
1030	70	1520	358	1686	289	1910	347	3109	143	4229	191	9200	180
1040	74	1521	362	1688	293	1915	355	3119	141			9230	177
1050	69	1522	364	1689	293	1920	325	3150	139	4412	185	9231	177
1065	43	1527	365	1690	296	1930	352	3157	145	4414	185	9237	178
1090	75	1529	366	1695	219	1940	338	3181	156			9238	178
				1696	219	1945	353	3184	156	7001	295	9240	176
		1601	245	1697	223	1950	322	3191	153	7002	294	9247	179
1101	84	1602	87	1698	223	1960	330			7003	295	9248	179
1102	84	1603	92	1699	244	1994	192	3200	137	7009	294	9250	171
1103	85	1604	95			1996	192	3207	144			9251	171
1104	85	1605	95	1802	79	1997	192	3217	142	8301	202	9252	172
1110	76	1606	95	1803	81	1999	192	3247	146	8302	202	9254	172
		1607	90	1804	80			3250	140	8303	202	9255	173
1405	29-54-55	1609	93	1806	80	2010	116			8304	202	9256	173
1406	30-44-54-64	1610	96	1807	79	2015	117	3300	165	8309	264	9257	174
1407	29-54-55	1611	94	1809	82	2016	117	3303	167	8310	203	9258	174
1408	30-54-55	1612	89	1819	82	2017	117	3305	166	8318	264	9260	170
1409	29-54-55	1615	291	1836	244	2530	119	3307	167	8319	265	9266	175
1435	273	1617	91	1846	235	2572	120	3310	168	8320	264-265	9267	175
1438	273	1620	292	1849	263	2575	118	3311	168	8321	207	9268	176
1456	21-28-36-44-52-55-63-64	1621	282	1851	258			3312	169	8325	206	9289	38
1459	21-28-36-44-52-63	1625	292	1852	258	2900	316			8326	207		
1460	241-273	1636	115	1853	260	2910	305	3404	157	8330	206	9411	184
1461	94-246-282-284-368	1637	284	1854	259	2930	310	3405	157	8331	266	9419	184
1462	21-28-36-44-52-63-67	1639	283	1855	260	2940	301	3406	158	8335	206	9459	183
1466	21-28-36-44-52-55-63-64-67	1640	270	1857	261	2950	318	3407	367	8341	206		
		1641	268	1858	259	2960	319	3409	155	8342	207	9674	182
		1642	254	1860	256			3415	159	8345	208		
		1643	281	1861	261					8350	204	9994	86
		1644	280	1862	262					8351	205		
		1645	247	1863	263			3500	147			M007	373
		1646	254	1864	262			3502	151	8900	194	M013	372
		1647	250	1869	213			3506	152	8901	194	M020	371
		1650	276	1870	226			3510	151	8904	195	M021	370
		1651	274					3536	150	8910	195	M640	379
		1653	274					3546	152	8920	196	M650	380
		1655	278									M836	378
		1659	113					3900	156			M880	377
		1660	68					3912	153			M881	378
		1661	252									M882	375
		1662	253									M886	376
												M890	374

Búsqueda por referencia (DISPLAY - PÁGINA)

Search by reference (Display - Page)

Recherche par référence (Display - Page)

Ref.	Pag.	Ref.	Pag.	Ref.	Pag.	Ref.	Pag.	Ref.	Pag.	Ref.	Pag.
D-01	215	D-13	27	D-25	216	D-37	230	D-49	35	D-61	212
D-02	215	D-14	51	D-26	216	D-38	279	D-50	20	D-62	20
D-03	221	D-15	73	D-27	217	D-39	279	D-51	52-240-271	D-63	360
D-04	228	D-16	35	D-28	217	D-40	279	D-52	20-236-269	D-64	290
D-05	219	D-17	61	D-29	217	D-41	281	D-53	317	D-65	112
D-06	223	D-18	65	D-30	217	D-42	281	D-54	95-245-283	D-66	114
D-07	236	D-19	248	D-31	213	D-43	149	D-55	269-275	D-67	212
D-08	239	D-20	356	D-32	213	D-44	123	D-56	275	D-68	212
D-09	239-243	D-21	356	D-33	221	D-45	216	D-57	275	D-69	233
D-10	271-277	D-22	123	D-34	221	D-46	51	D-58	269	D-70	231
D-11	279	D-23	236-272	D-35	228	D-47	62	D-59	62-240-272		
D-12	83	D-24	29-53	D-36	228	D-48	27	D-60	251		

Búsqueda por referencia (LÍNEA - PÁGINA)

Search by reference (Line - Page)

Recherche par référence (Ligne - Page)

Línea	Pag.	Línea	Pag.	Línea	Pag.
L-1001-1M	51	L-1645-1M	248	L-3207	144
L-1002-1M	61	L-1647-1M	251	L-3247	146
L-1003-1M	73	L-1650-1M	277	L-3409	155
L-1004-1M	19	L-1651-1M	274	L-3500	148
L-1005-1M	35	L-1655-1M	278	L-3510	151
L-1006-1M	27	L-1667-1M	112	L-3536	150
L-1007-1M	65	L-16FM-1M	290	L-3912	153
L-1010-1M	48	L-1836	244	L-4060	108
L-1013-1M	58	L-1846-1M	235	L-4061	109
L-1015-1M	42	L-1870	228	L-4062	110
L-1016-1M	24	L-1879	231	L-4067	107
L-1020-1M	32	L-1880-1M	238	L-4070	99
L-1021-1M	17	L-1881	242	L-4071	100
L-1027-1M	37	L-1883-1M	232	L-4072	101
L-14S1	53-237- 241-273	L-1886-1M	234	L-4076	103
L-14S2	218-237- 241	L-1890-1M	215	L-4077	98
L-1601	245	L-1891-1M	211	L-4078	97
L-1602	88	L-1892-1M	220	L-4079	102
L-1603	92	L-18PB	83	L-9200	170
L-1607	90	L-18PB-1M	83	L-M007-1M	373
L-1609	93	L-19C1-1M	356	L-M013-1M	372
L-1610	96	L-19C2-1M	356	L-M020-1M	371
L-1611	94	L-19SS-1M	335	L-M021-1M	370
L-1612	89	L-2530	119	L-M640-1M	379
L-1615	291	L-2572	120	L-M650-1M	380
L-1617	91	L-2575	118	L-M836	378
L-1620	292	L-2900-1M	317	L-M880-1M	377
L-1621	282	L-3001	130	L-M881	378
L-1625	292	L-3003	122	L-M882-1M	375
L-1639	283	L-3023	131	L-M886-1M	376
L-1640-1M	270	L-3109	143	L-M890	374
L-1641	268	L-3119	141	L-M890-1M	374
L-1644-1M	280	L-3157	145		
		L-3191	153		



COMERCIAL NACIONAL

E-mail comercial@izartool.com

Pedidos y Atención a Clientes

Tel. 94 630 02 41

Fax 94 630 02 36

Servicio Técnico

Tel. 94 630 02 43

Fax 94 630 05 42

EXPORT SALES

E-mail export@izartool.com

Orders & Customer Assistance

Tel. +34 94 630 02 46

Fax +34 94 630 02 37

VENTES FRANCE

Courriel france@izartool.com

Tel. +34 94 630 02 45

Parque Empresarial Boroa 2B2 - 48340 Amorebieta, Bizkaia (Spain)



LA CALIDAD TOTAL NOS DISTINGUE
Quality makes the difference
La qualité totale nous différencie



izartool.com